

PRESS INFORMATION

Cost-effectively automating battery production

Manuela Kessler | 22.04.2024 | Lohr am Main / Germany | PI 013/24

Bosch Rexroth offers a comprehensive portfolio of solutions for efficient, highly productive factory automation

- Comprehensive automation portfolio for the entire value stream
- Components, modules and system solutions from a single source
- Linear robots and many other economical complete solutions

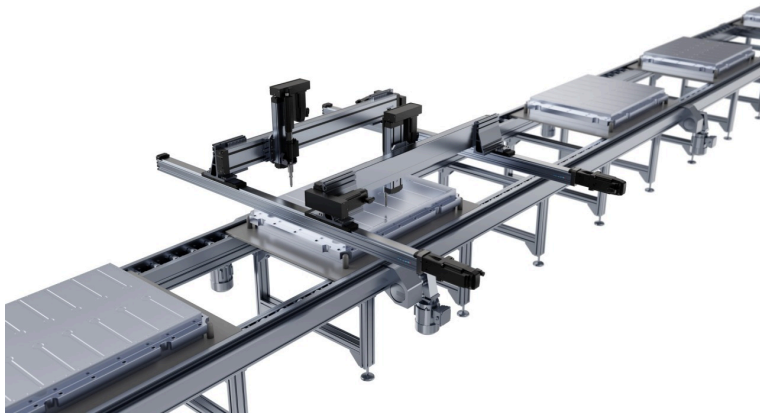

Highly productive battery assembly with a fast and precise linear robot. (Image source: Bosch Rexroth AG)

Battery production requirements are changing constantly. Bosch Rexroth supports machine and system manufacturers with a wide range of components and systems for the entire value stream to make it even more productive and economical. The key to short cycle times, low production costs and high flexibility lies in a broad, flexible automation portfolio with open interfaces for digital networking. At the Hannover Messe trade fair, Bosch Rexroth will be demonstrating how rapidly deployable linear robots optimize processes in module and pack assembly and disassembly by performing typical tasks such as handling, tightening or dispensing quickly and precisely. The Rexroth portfolio ranges from individual components, system solutions and subsystems in the technology areas of linear, joining and transfer systems to the comprehensive automation system ctrIX AUTOMATION.

Electromobility, consumer electronics, building technology – the demand for energy storage is greater than ever. To ensure short distances and reliable supply chains, many established and new battery manufacturers are building new capacities in Europe and the USA. Bosch Rexroth supports this development with comprehensive process expertise, many years of experience and a broad automation portfolio with worldwide service.

The Rexroth portfolio for battery production includes individual components, system solutions and subsystems from linear, joining and transfer system technology as well as the fully open automation system ctrIX AUTOMATION. It surmounts the classic boundaries between machine controls, the IT world and the Internet of Things. With the real-time capable operating system Linux, consistently open standards, app programming technology, web-based engineering and a comprehensive IoT connection, ctrIX AUTOMATION reduces components and engineering costs in battery production by 30 to 50 %.

PRESS INFORMATION

With the broad portfolio of hardware and software solutions, a wide range of solutions can be implemented and networked throughout the entire value stream. At the heart of the automation system is the control ctrlX CORE, which acts as a link between automation technology, connection technology and material handling. The drive system ctrlX DRIVE complements the solution portfolio for battery production with compact and modular servo drives and servo motors.

Material handling includes system solutions such as the FTS flexible transport system, which moves and precisely positions materials and workpieces for cell manufacturing, and the VarioFlow chain conveyor system for high automation densities and confined spaces. The TS 2 Booster transfer system shortens cycle times with fast short transfers.

The TS5 and TS7 transfer systems are suitable for transporting the heaviest loads in the harsh environmental conditions of module and pack assembly. Their design makes them particularly robust and their low-maintenance drive concept ensures high system availability. The autonomous mobile robot ACTIVE Shuttle transports battery packs and other components and materials through the factory halls both cyclically and on demand.

Bosch Rexroth guarantees a high degree of freedom, process reliability and precision in pack assembly with the NEXO cordless nutrunner and the OPEX torque wrench, which meets all requirements for safety-critical bolting in accordance with VDI/VDE 2862.

Productive linear robots with open interfaces

As a further cost-efficient complete solution for module and pack assembly, Bosch Rexroth offers linear robots for typical applications such as handling cells or packs, tightening or dosing. The high mechanical rigidity and repeatability across the entire working area is essential for many processes. In order to achieve short cycle times, several processes can also be mapped simultaneously on a linear robot, for example tightening processes.

The linear robots from Bosch Rexroth are supplied as complete mechatronic packages, optionally with pre-installed operating software. This allows them to be quickly commissioned, sequenced and connected to the higher-level line control system. Open interfaces for connecting various end effectors such as grippers, dispensing heads or the Smart Flex Effector from Bosch Rexroth, which received the Hermes Award in 2023, ensure the greatest possible flexibility of use. The Smart Flex Effector allows industrial robots to act as sensitively as a human hand, enabling even complex processes to be automated.

For the dry room, Bosch Rexroth offers durable linear guides, optionally with an integrated measuring system IMS, as well as ball screw assemblies and electromechanical cylinders and complete subsystems for pressing and joining applications.

PRESS INFORMATION

The complete automation portfolio for battery production ranges from electrode and cell production to end-of-line testing and the discharging process for recycling.

Basic Information Bosch Rexroth

As one of the world's leading suppliers of drive and control technologies, Bosch Rexroth ensures efficient, powerful and safe movement in machines and systems of any size. The company bundles global application experience in the market segments of Mobile and Industrial Applications as well as Factory Automation. With its intelligent components, customized system solutions, engineering and services, Bosch Rexroth is creating the necessary environment for fully connected applications. Bosch Rexroth offers its customers hydraulics, electric drive and control technology, gear technology and linear motion and assembly technology, including software and interfaces to the Internet of Things. With locations in over 80 countries, around 33,800 associates generated sales revenue of 7.6 billion euros in 2023.

Basic Information Bosch

The Bosch Group is a leading global supplier of technology and services. It employs roughly 429,000 associates worldwide (as of December 31, 2023). The company generated sales of 91.6 billion euros in 2023. Its operations are divided into four business sectors: Mobility, Industrial Technology, Consumer Goods, and Energy and Building Technology. With its business activities, the company aims to use technology to help shape universal trends such as automation, electrification, digitalization, connectivity, and an orientation to sustainability. In this context, Bosch's broad diversification across regions and industries strengthens its innovativeness and robustness. Bosch uses its proven expertise in sensor technology, software, and services to offer customers cross-domain solutions from a single source. It also applies its expertise in connectivity and artificial intelligence in order to develop and manufacture user-friendly, sustainable products. With technology that is "Invented for life," Bosch wants to help improve quality of life and conserve natural resources. The Bosch Group comprises Robert Bosch GmbH and its roughly 470 subsidiary and regional companies in over 60 countries. Including sales and service partners, Bosch's global manufacturing, engineering, and sales network covers nearly every country in the world. Bosch's innovative strength is key to the company's further development. At 136 locations across the globe, Bosch employs some 90,000 associates in research and development, of which nearly 48,000 are software engineers.

Press Contact

Please get in touch with our Press Contact



Manuela Kessler

Spokesperson
technology topics
+49 9352 184145

Manuela.Kessler@boschrexroth.de