

MP18/SIC & SIO Stacking Valve System Technical Information Manual

The Drive & Control Company

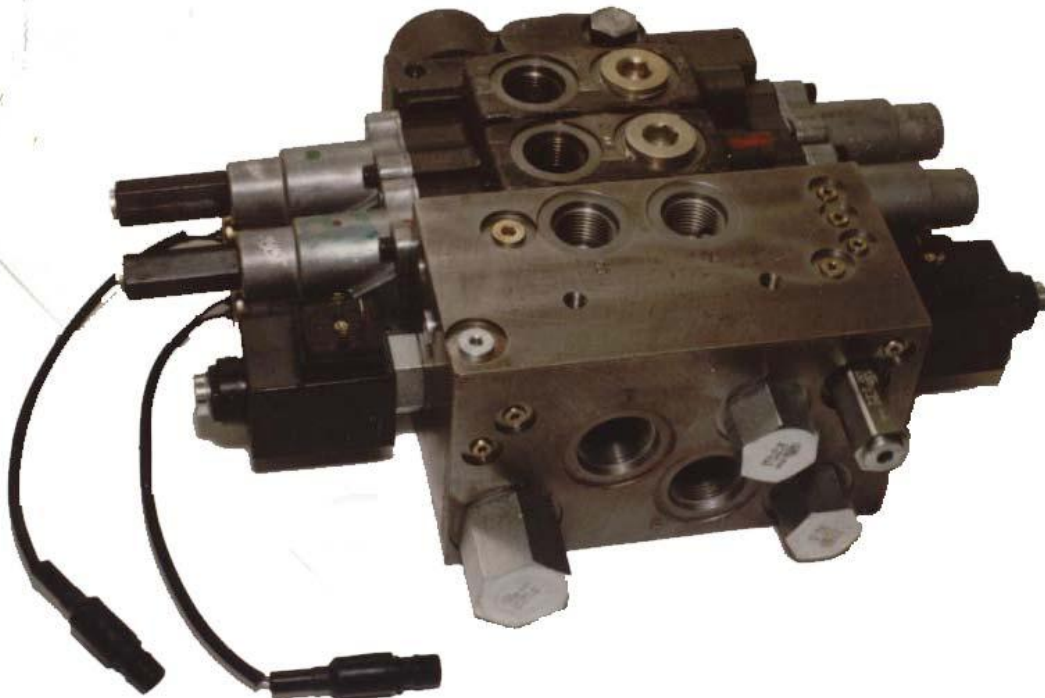

Copyright © 1996 Bosch Rexroth Canada Corp.

All rights reserved.

Reproduction or use of editorial or pictorial content in any manner is prohibited without the express permission of:

BOSCH REXROTH CANADA CORP.

While every precaution has been taken in the preparation of this manual, the publisher assumes no responsibility for errors or omissions. Neither is any liability assumed for damages resulting in the misuse of the printed material contained herein.

First Edition 1996

Revised Edition 2006

Printed in Canada for:

Bosch Rexroth Canada Corp.
3426 Mainway Drive
Burlington, Ontario
Canada L7M 1A8

Phone: (905) 335-5511

Fax: (905) 335-9859

Toll Free: 1-877-266-7811

1-877-COMPU-11

TABLE OF CONTENTS

TABLE OF CONTENTS 3
FEATURES..... 4
FUNCTIONAL PURPOSE 4
DESCRIPTION 5
SPECIFICATION 6
 Pressure 6
 Flow 6
 Solenoids 110 – MP18/ SIC and SIO 6
 Solenoids 110 –MP 18 Sections Only 6
SPECIFICATIONS CONTINUED 7
 Torque Values SIC and SIO Cartridges 7
OPERATING CONDITIONS 8
 Recommended Filtration 8
PRESSURE ADJUSTMENTS 8
 Open Centre Unloading Inlet 8
PRESSURE ADJUSTMENTS 9
 A and B Port Reliefs 9
UNIT DIMENSIONS 10
HIGH BOY / LOW BOY MANIFOLD SECTIONS 12
BUILDING A MANIFOLD BANK ASSEMBLY 13
 What You Need to Build a Valve Assembly 13
BUILDING A MANIFOLD BANK ASSEMBLY 14
 Recommended Assembly Order 14
PROBLEM SOVING GUIDE..... 15
STANDARD SPARE PARTS..... 17

FEATURES

- Modular (stacked) Design for Custom Application
- Open and Closed Centre Inlets are Available
(for use with fixed or variable displacement pumps)
- Pressure Control is Built in
- Flow Control is Independent of Load
- Sections Operate Independently of Each Other
- Load Checks are Built In
- Manual Overrides are Incorporated
- Long Service Life
- Small Size
- Cast Iron Construction
- Economical

FUNCTIONAL PURPOSE

This combination manifold block plus stacking manifold section type valve system provides modular building blocks for constructing hydraulic circuits to meet the needs of any spreader truck application.

Inlet manifold blocks are available to accept the flow from variable (piston) or from fixed (gear) pumps in an energy efficient manner.

Valve cartridges in the inlet manifold block allow for electronic control of the spreader hydraulic motors. In this way, the operator can vary the spinner speed and the Compu-spread electronic controller can automatically vary the material conveyor/auger speed, according to the vehicle speed, maintaining a selectable and constant spread rate.

The spreader valve circuit is extendable to control the other hydraulic actuators on your truck (such as: plow functions and dump hoists) simply by adding valve manifold sections. Any of these additional valve sections can also be electronically controlled or they may be operated by on/off electrical solenoids, proportional air pilots, mechanical cables or levers. You may also add mechanical detents and/or port relief valves with make up checks to any of these additional valve sections.

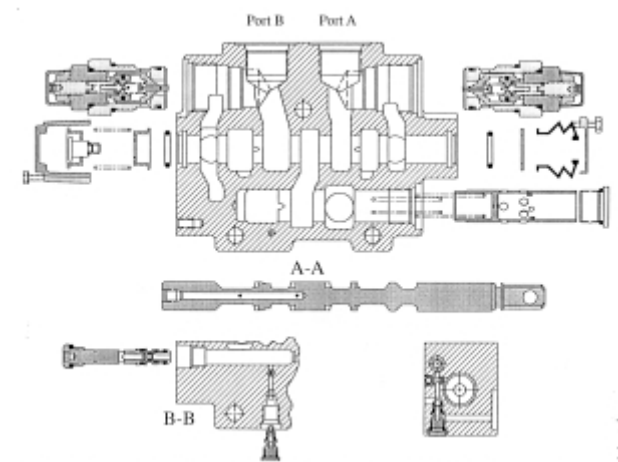

Modular stacking valve spool section

DESCRIPTION

The 110-MP18/SIC and SIO manifold blocks contain the integrated circuit valving for the spreader hydraulic functions (conveyor/auger and spinner motor drives). These manifold blocks may have a combination of individual manifold sections bolted onto them. These additional manifold sections contain integrated circuit valving for other specific hydraulic functions, such as the plow hoist cylinder, and are bolted together to form a system specifically suited to your particular vehicle.

There are two manifold blocks to choose from. A closed centre circuit is incorporated in one, for use with variable displacement piston pumps. This block has a load (pressure) sensing port for communicating the system's requirements to the pump's control valves. In this way the pump will limit the maximum pressure that can be produced and will only provide the power that your hydraulic system requires. Reference MP18/SIC Block.

If a fixed displacement pump is to be used, the other manifold has an open centre circuit. This block includes a relief valve, to limit the maximum pressure that can be produced. The relief valve also provides a load (pressure) sensing control based on the system's requirements. In this way the excess flow, provided by the pump, is bypassed to the reservoir at no greater pressure than necessary, reducing the power wasted (heat) that occurs in fixed displacement pump systems. Reference MP18/SIO Block.

A load (pressure) sensing circuit within the valve manifolds determines the maximum pressure requirement of your vehicle and communicates this information to the main pressure control valve. This main pressure control valve could be in the pump for variable displacement types or in the inlet block of this valve assembly, if a fixed displacement pump is used.

The spreader valve cartridges have spools that are positioned by electronic solenoids, to control the oil flow to, and therefore speed of, the hydraulic motors. The flow is controlled proportionally to the electric current supplied. Any additional valve sections (ie: for plow functions) can also be electronically controlled or they may be operated by on/off electrical solenoids, proportional air pilots, mechanical cables or levers.

Each valve function contains a pressure control valve that monitors the load (pressure) requirement of its hydraulic actuator and provide constant fluid flow (compensates) regardless of load changes and regardless of other valve function activity. By doing this, control is consistent and repeatable.

Manual overrides are provided for emergency operation of the valves should the electronic controller fail and to aid in trouble shooting the system. There is an override pin in the end of each electrical solenoid. The harder the pin is pushed the faster the hydraulic motor should turn. There is also an override screw available at the end of the main valve spools. By turning these screws in, you can position the spools to establish a desired hydraulic motor speed (see the spare parts illustration of the end caps).

This modular arrangement allows the addition of auxiliary sections for plow and wing functions. For further assistance when specifying additional valve sections please consult your nearest Bosch Rexroth location.

SPECIFICATION

Pressure

Maximum Primary Relief Setting 3,000 P.S.I.
 Maximum Secondary Relief (actuator pressure) 3,500 P.S.I.

Flow

Maximum Flow 35 G.P.M. (133L/Min.)

Solenoids MP18 SIC and SIO

Proportional	P/N 150235 12 Volt	P/N 121777 24 Volt
Type of Supply	DC	DC
Nominal Voltage (V)	12	24
Control Current, max (A)	2.0	1.0
Coil Resistance 68°F (20°C) (ohms)	4.8 ± 10%	19 ± 10%
Duty in (%)	100	100

Solenoids MP 18 Sections Only

On/Off	P/N 029636 12 Volt	P/N 029752 24 Volt
Type of Supply	DC	DC
Nominal Voltage (V)	12	24
Power Requirement at 68°F (20°C) (W)	14.4	14.4
Coil Resistance (ohms)	10	40
Duty in (%)	100	100

Proportional	P/N 138956 12 Volt	P/N 202707 24 Volt
Type of Supply	DC	DC
Nominal Voltage (V)	12	24
Control Current, max (A)	1.8	0.8
Coil Resistance 68°F (20°C) (ohms)	2.4	12
Duty in (%)	100	100

SPECIFICATIONS CONTINUED

Torque Values SIC and SIO Cartridges

If it is necessary to remove or replace any of these cartridges, please torque as specified.

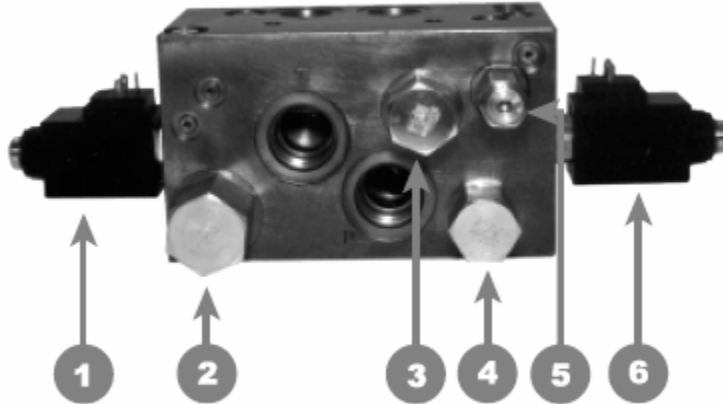

Proportional Flow Cartridge Auger/Conveyor 15-18 ft/lbs., 20-24 (Nm)

1. Differential Sensing Valve 25-30 ft/lbs., 34-41 (Nm)
2. Differential Sensing Valve 15-18 ft/lbs., 20-24 (Nm)
3. Differential Sensing Valve 15-18 ft/lbs., 20-24 (Nm)
4. Relief Valve 25-30 ft/lbs., 47-54 (Nm)
5. Proportional Flow Cartridge Spinner 10-12 ft/lbs., 14-16 (Nm)

Upon assembly, check the following:

- Prepare the cartridge for Insertion into the block
- Check that the cartridge is free of contamination
- Check that "O" rings and back-up rings are intact
- Dip Cartridge into clean oil, to top of the threads, to lubricate O rings.

8 Sections Maximum

NOTE: Please consult Bosch Rexroth when ordering 8 or more sections.

OPERATING CONDITIONS

Recommended Filtration

In order to guarantee reliable function, both return and pressure filters should have 10 micron absolute elements installed.

PRESSURE ADJUSTMENTS

Open Centre Unloading Inlet

Turn the maximum pressure adjustment screw (as shown) counter clockwise as far as possible. To do this, you must first remove protective cap.

While "Dead Heading" one of the valve functions, turn the pressure adjustment screw clockwise as far as possible. To do this you must first loosen the jam nut.

While dead heading valve function with port relief turn the pressure adjustment screw clockwise.

NOTE: Ensure a 3,000 P.S.I. pressure gauge is installed in the pressure line from the pump. Turn until you read the maximum pressure your system requires on the pressure gauge (usually 1500-2500 P.S.I.).

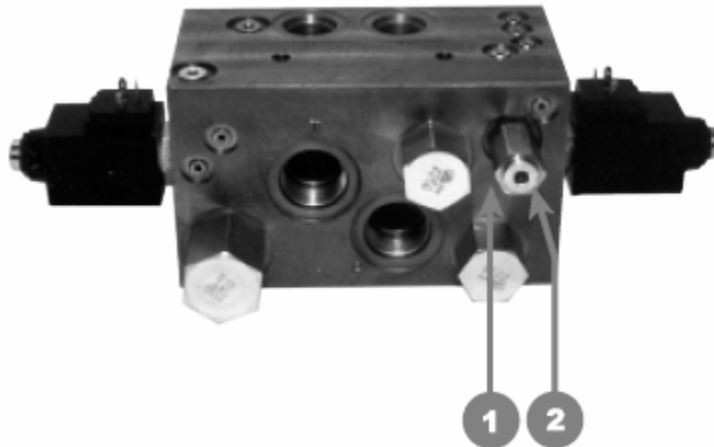

MP18 / SIO Block

1. Unloader Relief Valve Cartridge
2. Protective Cap

NOTE: Remove cap first to expose internal adjustment for relief setting. Replace protective cap as required.

PRESSURE ADJUSTMENTS

A and B Port Reliefs

Turn the maximum pressure adjustment screw (as shown) counter clockwise as far as possible. To do this you must first loosen the jam nut (as shown).

While dead heading valve function with port relief, turn the pressure adjustment screw clockwise. Turn until you read the desired pressure on the pressure gauge. Tighten the jam nut to secure setting.

NOTE: As per spare parts information, be aware of relief cartridge you are using. Low pressure relief range is 300- 1400 psi and high pressure relief is 1450-3625 psi.

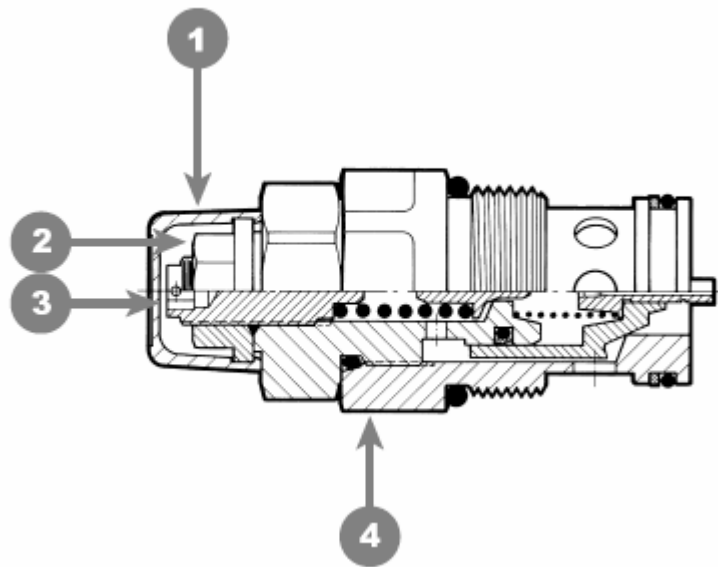

1. Protective Plastic Cap
2. Jam Nut
3. Pressure Adjustment Screw 3/16" Allen Head
4. Port Relief Cartridge

UNIT DIMENSIONS

MP18/SIC AND SIO STACKING HYDRAULIC VALVE SYSTEMS

Standard Port Sizes (SAE)

Inlet Section	P (Inlet)	T (Tank)	LS (Load Sense)	
Closed Centre	# 16	# 16	# 6	
Open Centre	# 16	# 16	_____	
Spool Section	A & B (Work Ports)			
	# 12			
End Cover	P (Inlet)	T (Tank)	LS (Load Sense)	T2 (Drain)
L (CPL)	# 12	# 12	# 4	_____
Q	_____	_____	_____	# 4
Q (CPL)	# 16	# 16	# 4	# 4

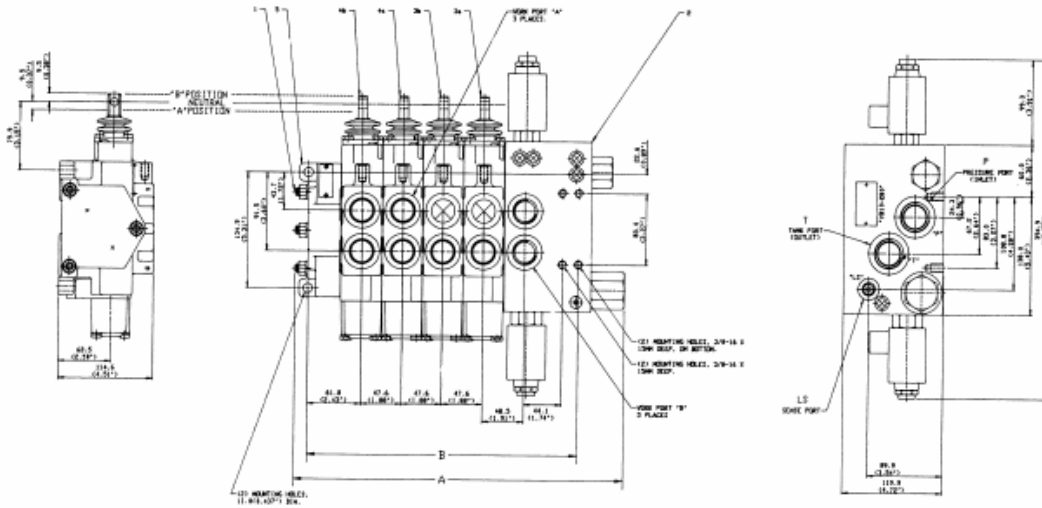

UNIT DIMENSIONS

MP18 / SIC AND SIO STACKING HYDRAULIC VALVE
SYSTEM CONTINUED

Closed Centre Inlet with Standard End Cover

Number of Directional Control Spools	Overall Length A		Bolt Hole Covers B	
	IN	MM	IN	MM
1	9.30	236.20	7.15	181.60
2	11.20	284.50	9.05	230.00
3	13.00	330.20	10.85	275.60
4	15.00	381.00	12.85	326.40
5	16.80	426.70	14.65	372.10
6	18.70	475.00	16.55	420.40
7	20.60	523.20	18.45	468.60
8	22.40	567.00	20.25	514.30

Open Centre Inlet with Standard End Cover

Number of Directional Control Spools	Overall Length A		Bolt Hole Covers B	
	IN	MM	IN	MM
1	9.40	238.70	7.15	181.60
2	11.30	287.00	9.05	230.00
3	13.20	335.30	10.85	275.60
4	15.00	381.00	12.85	326.40
5	16.90	429.20	14.65	372.10
6	18.80	477.50	16.55	420.40
7	20.70	525.80	18.45	468.60
8	22.60	574.00	20.25	514.30

HIGH BOY / LOW BOY MANIFOLD SECTIONS

“High Boy” manifold sections are taller than “Low Boy” manifold sections. This extra height allows for material that may be machined to accept work port (“A” & “B”) relief valves cartridges w/make up checks. These optional valve cartridges are provided if over pressure protection is desired for the hydraulic actuators (motors or cylinders). Over pressure protection may be desired if a plow cylinder is forced to move by the load. Without protection, the pressure may build to a high enough level to damage the cylinder or burst a hose.

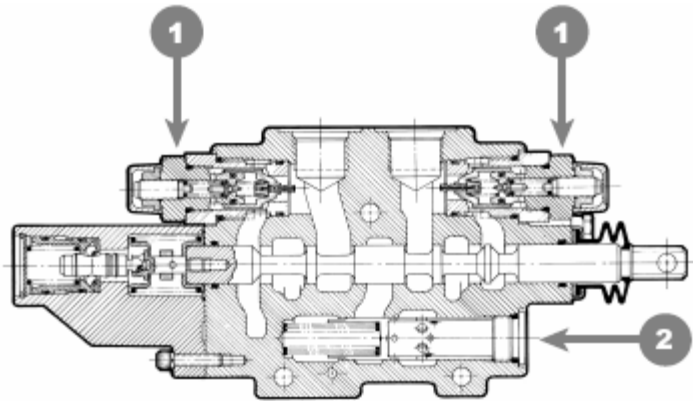

High Boy

1. Work port optional valve cartridges
2. Compensator spools with fixed flow limit

“High Boy” manifold sections will accept compensator spools that provide a fixed maximum flow limit. “Low Boy” manifold sections will not.

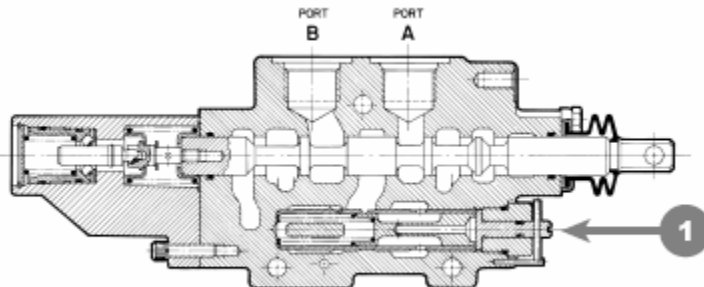

Low Boy

1. Compensator spools with adjustable flow limit

“Low Boy” manifold sections will accept compensator spools that provide an adjustable flow limit (3 to 30 GPM). “High Boy” manifold sections will not.

BUILDING A MANIFOLD BANK ASSEMBLY

What You Need to Build a Valve Assembly

1. Arrange the manifolds in the following order according to function, on a flat surface.

You will require:

1.1 One inlet section

(Part No. 162734 - closed centre for variable displacement piston pumps)

(Part No. 162717 - open centre for fixed displacement gear pumps)

1.2 One to eight main valve sections

1.3 One end cover

Use P/N 016463 or 003857 if assembly has one or more electrical sections

Use P/N 018095 or 005120 if assembly has no electrical sections.

1.4 One tie bolt kit consisting of:

- o-rings
- shims
- three tie bolts
- lock washers
- nuts
-

For Part No. see Bolt Kit listing under spare parts

1.5 one dust boot kit for each mechanically (cable or air) actuated section. Part No. 014244

1.6 four O-rings for each electrically or electronically actuated section. Part No. 005974

2. Lubricate the O-rings with clean hydraulic oil and put them in place.

3. Insert the tie bolts, ensuring that there is one (and only one) shim on each tie bolt between each manifold section.

4. Loosely install the lock washers and nuts.

5. Ensure that all manifold sections are flush against the flat surface.

6. Torque the tie rod nuts to 28 ft/lbs.

BUILDING A MANIFOLD BANK ASSEMBLY

Recommended Assembly Order

1. Inlet
2. Spinner
3. Conveyor/Auger
4. Dump Body
5. Plow Angle (Plow Reverse)
6. Front Plow (Plow Up)
7. Wing Toe
8. Wing Heel
9. Wing Brace
10. End Cap

NOTE: If items 4-9 as above are not electrical or proportional sections place them between inlet and spinner section.

PROBLEM SOVING GUIDE

Problem	Probable Cause	Corrective Action
High P-T Pressure Drop	<ul style="list-style-type: none"> • Sticky unloading valve spool • Sticky main spool – not neutral 	<ul style="list-style-type: none"> • Remove, clean and flush inlet • Record LS pressure at inlet plug, shift main spools to determine which is sticky • Remove, clean and flush section
High or Low System Pressure	<ul style="list-style-type: none"> • Wrong main relief setting • Wrong pump compensator setting • Loss of pilot signal at LS port • Low setting of cyl, port relief valve or section pressure regulator 	<ul style="list-style-type: none"> • Re-adjust main relief valve • Re-adjust pump compensator • Dirt in shuttles, Dead head all ports starting from first section to determine which shuttle may have dirt. Remove shuttle, clean and flush section. • Check and re-adjust cyl. Port relief valve or section pressure regulator
Pump stays at high pressure	<ul style="list-style-type: none"> • Sticky main spool • Sticky compensator spool • Actuation pressure does not drain 	<ul style="list-style-type: none"> • See sticky spool below • Remove compensator spool and inspect for dirt or damage. Clean spool and flush valve if dirty. If spool is damaged, change section. • Check that actuation pressure from pilot controller is at 0 PSI. If this occurs in an electrical section, remove the solenoid and inspect that the spool is free. Blow in end of solenoid valve, air should come out tank drain. procedure in previous section.
Can build pressure or obtain flow from one port only	<ul style="list-style-type: none"> • Dirt in primary shuttle or damaged O-ring on shuttle 	<ul style="list-style-type: none"> • Remove primary shuttle, check O-ring, clean and replace O-rings if required. Flush valve and re-install shuttle.
No pressure or flow at either work port	<ul style="list-style-type: none"> • Dirt in secondary Shuttle 	<ul style="list-style-type: none"> • Starting with first spool, shift in both directions with blocked work ports. Work towards end cover, testing each section until you come to section which will not build pressure. Remove and check O-ring, replace if required clean and flush the secondary shuttle in this section. If you still can't build pressure, repeat

PROBLEM SOLVING GUIDE

Problem	Probable Cause	Corrective Action
High work port leakage	<ul style="list-style-type: none"> • Dirt in cyl. port relief valve • Damaged relief valve seals • Spool not centered 	<ul style="list-style-type: none"> • Remove, clean, flush, re-install • inspect and replace as required • Check for sticky spool
Leaks between sections	<ul style="list-style-type: none"> • Missing or damaged face seals 	<ul style="list-style-type: none"> • Disassemble valve stack & check for missing or damaged O-rings
Sticky spool	<ul style="list-style-type: none"> • Damaged spool • Linkage binding • Uneven torque of tie rods of mounting bolts • Incorrect number of shims on tie rods 	<ul style="list-style-type: none"> • Remove & inspect, if damaged change section • Check linkage for friction, clean and lubricate • Loosen mounting bolts, if spool is free, re-mount on level surface. Loosen tie rods and re-torque to 22 - 25 ft. lbs. with valve on level surface. • Disassemble and check that each tie rod has only 1 shim between each section
Flow control will not provide constant flow	<ul style="list-style-type: none"> • Stuck flow control spool 	<ul style="list-style-type: none"> • Disassemble flow control and inspect for dirt or damage causing sticky spool in tube. If dirty, clean & flush valve and reassemble. If damaged, replace section
Detent will not hold	<ul style="list-style-type: none"> • Broken detent shaft 	<ul style="list-style-type: none"> • Remove detent housing & inspect shaft. If damaged, clean housing replace shaft.
Electrical sections will not function	<ul style="list-style-type: none"> • Broken electrical connection • Burned out solenoid coil • No pilot pressure to solenoid valves 	<ul style="list-style-type: none"> • Check for proper electrical connections. Actuate manual override pin on solenoid to determine if problem is electrical or hydraulic. • Check resistance of coil (see coil specifications in this module) If value out of range replace solenoid assembly. • Check pressure at P2 port in end cover for pilot supply pressure. If pressure is below 100 PSI the pressure reducing valve is stuck. Remove & clean the pressure reducing valve & flush end cover

STANDARD SPARE PARTS

Seal Kits

Part Number	Description
008716	O-rings and shims required for between any two sections

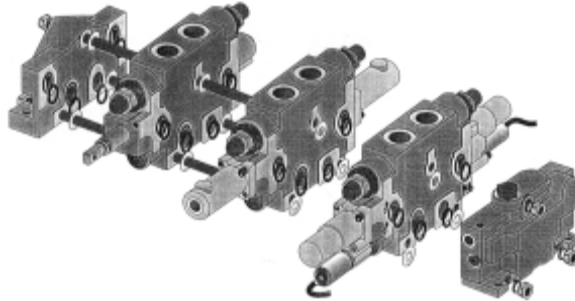

Bolt Kits

Including:

- shims
- O-rings
- tie-bolts
- nuts & lock washers

For Closed Centre Applications (Variable Displacement Pumps)

Part Number	Description
019304	3 function
014123	4 function
003739	5 function
010898	6 function
016499	7 function
016498	8 function
016501	9 function
016500	10 function

For open centre applications (fixed displacement pumps)

Part Number	Description
019304	3 function
014123	4 function
003739	5 function
010898	6 function
016499	7 function
016498	8 function
016501	9 function
016500	10 function

STANDARD INLET SPINNER AND AUGER SECTION

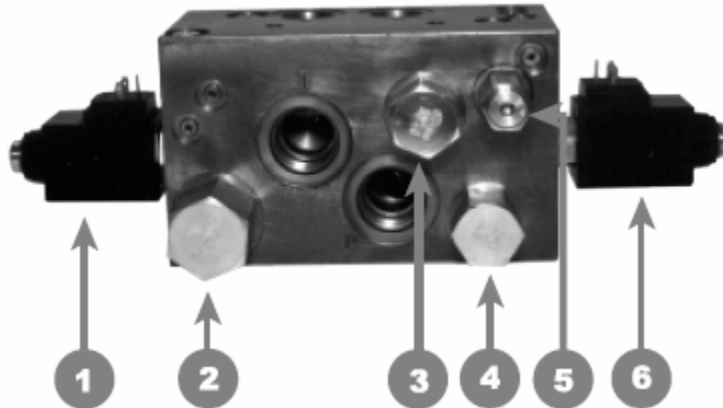

Open Center Model MP/SIO P/N 162717

Part Number	Description
242473	CP551-30-B-0-5H-12D-H Auger/Conveyor Proportional flow control
150235	321318 Replacement 12 Volt Coil only
121777	320814 Replacement 24 Volt Coil only
120053	Seal Kit
131087	CP702-4-B-0-150 Differential Sensing Valve (for Auger) 120033 seal kit
013378	CP701-1-B-0-150 Differential Sensing Valve (for Unloader)
120013	Seal Kit
002089	CP701-4-B-0-150 Differential Sensing Valve (for Spinner)
120013	Seal Kit
121659	CP208-1-13-0-A-C-150 Relief Cartridge (for Unloader)
120221	Seal Kit
131967	CS-550-30-B-0-3H-12D-H Spinner Proportional Flow Control
131517	120009 seal kit
	Replacement coil see Auger/Conveyor Proportional Flow Control.

STANDARD INLET SPINNER AND AUGER SECTION

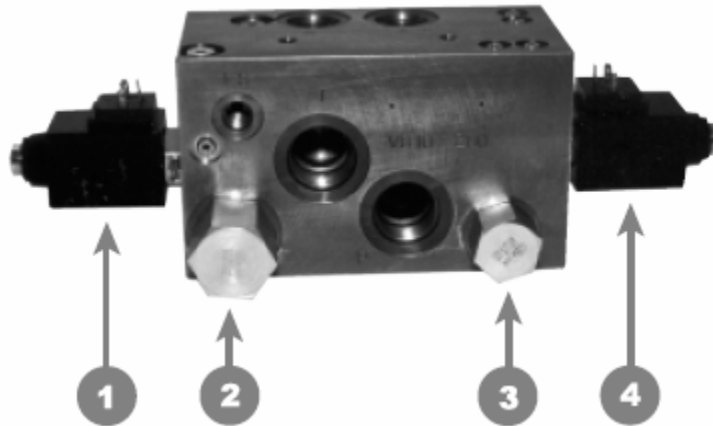

Closed Center Model MP18/SIC P/N 162734

Part Number	Description
242473	CP551-38-B-0-5H-12D-H Auger/Conveyor Proportional flow control
150235	321318 Replacement 12 Volt Coil only
121777	320814 Replacement 24 Volt Coil only 120053 seal kit
131087	CP702-4-13-0-150 Differential Sensing Valve (for Auger) 120033 seal kit
002089	CP701-4-B-0-150 Differential Sensing Valve (for Spinner) 120013 seal kit
242476	CP550-80-B-0-3H-12D-H Spinner Proportional Flow Control
131517	120009 seal kit Replacement coil see Auger/Conveyor Proportional Flow Control.

STANDARD SPARE PARTS

Secondary Port Options (for high boy sections only)

Part Number Description

016497 relief valve cartridge w/make up check
(for over load protection at "A" or "B" port option, 300 - 1400 PSI application)

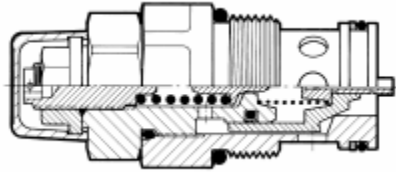

012357 relief valve cartridge w/make up check
(for over load protection at "A" or "B" port option, 1450 - 3625 PSI application)

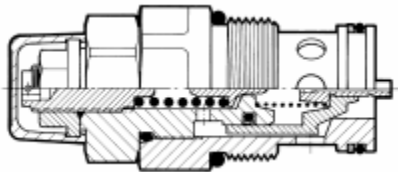

019310 "A" or "B" port option plug

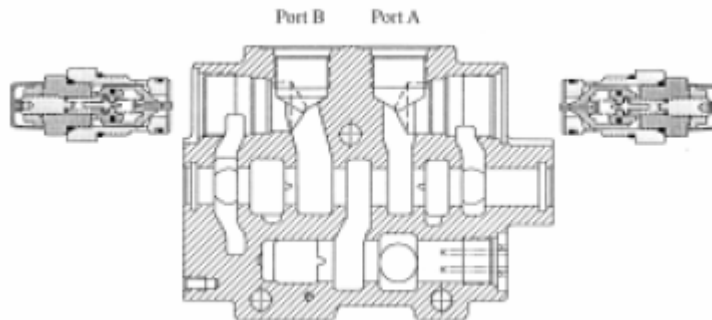
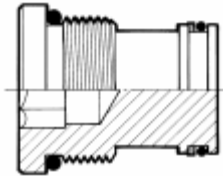

STANDARD SPARE PARTS

Primary Shuttle Assembly

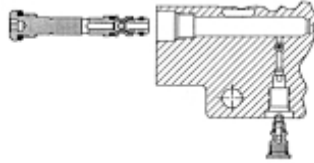

Part Number	Description
016490	double acting "A" & "B"

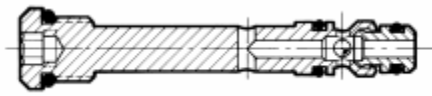

150424	single acting "B"
--------	-------------------

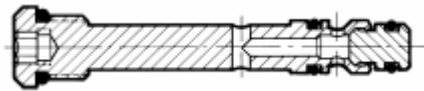

019307	single acting "A"
--------	-------------------

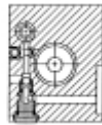
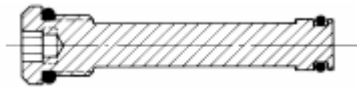

Part Number	Description
160794	ball and seat plug

STANDARD SPARE PARTS

Flow Controls and Compensators

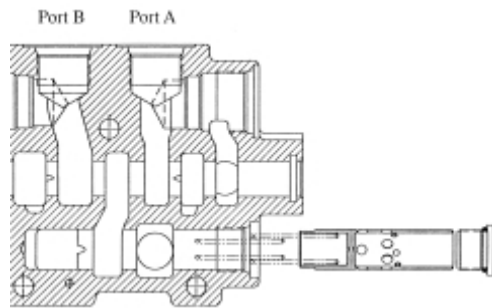

Part Number	Description
129648	long stem adjustable flow control, low boy only (3 to 30 GPM)
123883	short stem adjustable flow control, low boy only (3 to 30 GPM)

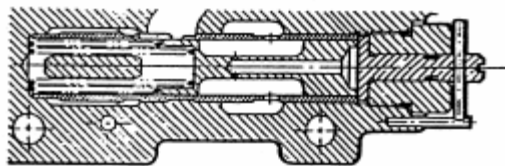

123925	solid compensator kit low or high boy (35 GPM)
--------	--

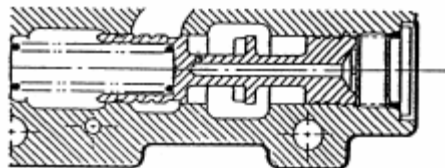

123911	hollow compensator kit, high boy only (15 GPM)
132478	hollow compensator kit, high boy only (30 GPM)
104337	compensator spool (15 GPM)
020416	compensator spool (30 GPM)

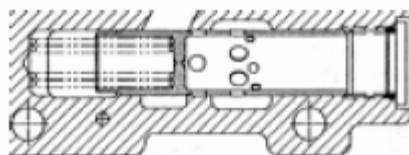

STANDARD SPARE PARTS

Directional Valve Spools

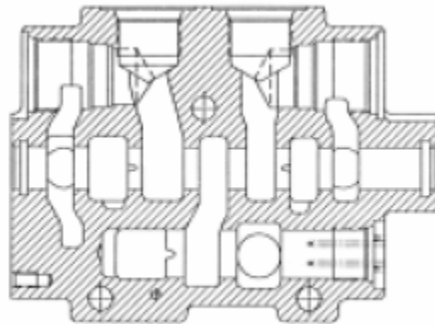

For use with electrical / electronic solenoids or with hydraulic pneumatic pilots

Part Number	Description
016484	11 GPM for cylinders
016483	15 GPM for cylinders
109872	24 GPM for cylinders
016488	35 GPM for cylinders
110548	11 GPM for motors
110299	15 GPM for motors
185559	24 GPM for motors
110366	35 GPM for motors

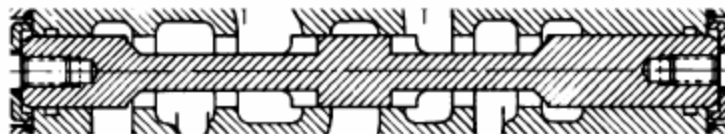

For use with mechanical cables / levers

Part Number	Description
110457	35 GPM for cylinders
106962	35 GPM for motors

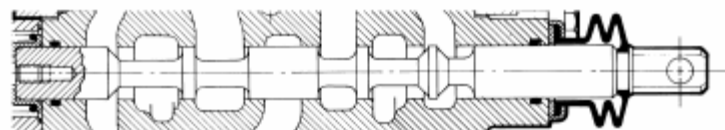

STANDARD SPARE PARTS

Section End Caps	Part Number	Description
	144529	"A" end without solenoid assembly with manual override screw
	027297	"B" end without solenoid assembly with manual override screw
	113192	blank end cap

NOTE: Manual override screws may be turned in until they push the main valve spool far enough to allow oil to flow to the hydraulic motor. Once the motor is running at the desired speed, the override may be locked in place. This feature will allow the operator to continue to spread material if the electronic spreader control fails.



Solenoid Assembly

Electrical on/off	Part Number	Description
	029636	12 volt (10 ohms)
	029752	24 volt (40 ohms)
Electronic proportional	202706	12 volt (2.4 ohms)
	202707	24 volt (12 ohms)



O – Rings for between end caps and manifold section

Part Number	Description
006048	large diameter (either end)
007646	small diameter ("A" end only)
005974	small diameter ("B" end only)



A END



B END

STANDARD SPARE PARTS

Mechanical Accessories

Part Number	Description
004779	lever assembly c/w dust boot kit
014244	dust boot kit only

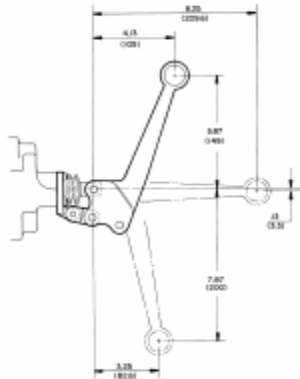

Pilot Options

Part Number	Description
200585	hydraulic housing
167619	Del pneumatic (air) shifter

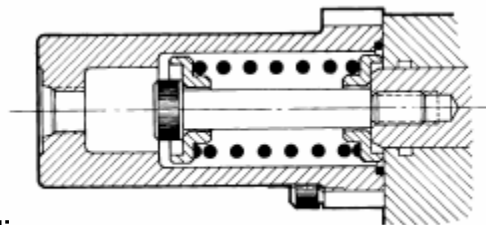

Detent Assemblies

Part Number	Description
019315	Code "E" for plow down (spring centre / detent on "A")
019316	Code "J" for plow float (spring centre / fourth position)
019313	Code "A" operator kit (spring centre)

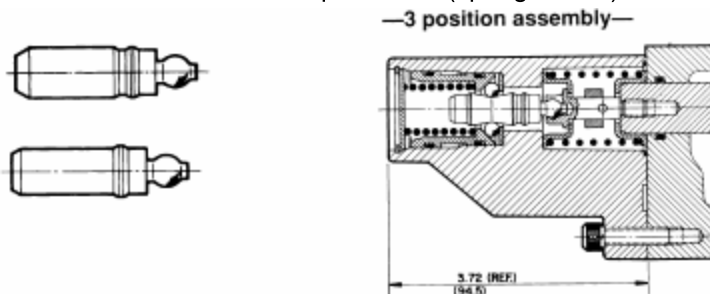

STANDARD END COVERS

Part Number Description

016463 for use with electronic / electrical solenoid operated valve sections

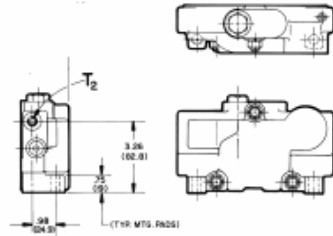

003857 same as above with auxiliary "P", "T" and "LS" ports

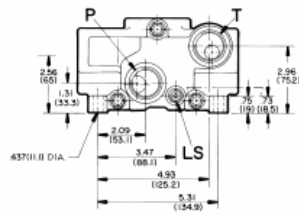

018095 for use with mechanical cable / lever or hydraulic / pneumatic operated valve sections

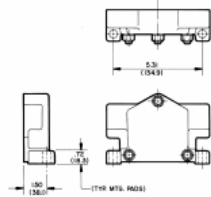

005120 same as above with auxiliary "P", "T" and "LS" ports

