

Hägglunds Atom Powerfully fast reaction

HÄGGLUNDS 

A mini hydraulic motor with magnified power

It may be tiny and light, but within the Hägglunds Atom motor is the power to change everything. This miniscule package is a flurry of energy, where revolutions occur at blinding speed. Yet most surprising is its strength – an elemental force that far surpasses its size.

The Atom delivers a maximum torque of up to 13.6 kNm. Since the motor can supply full torque at its top speed of 400 rpm, that gives it a maximum power of 394 kW that outstrips others in its class.

All that power comes bundled in an extremely compact design withstanding harsh environments, which makes the

Atom a perfect fit for mobile and marine applications. At the same time, a peak pressure of 420 bar lets it withstand shock loads, making it a match for shredders and other tough and unpredictable applications.

As durable and constant as it is quick to react, the Atom unleashes possibilities when fused with your machines.



MOTOR DATA, HÄGGLUNDS ATOM

Frame size	Nominal size	Specific torque		Displacement		Maximum torque ³⁾		Max pressure ⁴⁾		Maximum speed rpm	Maximum operating power ⁵⁾	
		Nm/bar	lb _f -ft/1000 psi	cm ³ /rev	in ³ /rev	Nm	lb _f -ft	bar	psi		kW	hp
Atom 10	8	8	407	503	30.7	2728	2012	350	5076	400	113	151
	10	10	509	628	38.3	3410	2515	350	5076	400	140	188
	12.5	12.5	636	785	47.9	4263	3144	350	5076	400	173	232
Atom 20	16	16	814	1005	61.3	5457	4025	350	5076	400	224	300
	18	18	915	1131	69.0	6139	4528	350	5076	400	250	336
	20	20	1017	1257	76.7	6821	5031	350	5076	400	277	371
	22.5	22.5	1144	1414	86.3	7673	5660	350	5076	400	309	414
	25	25	1271	1571	95.9	8526	6288	350	5076	400	340	456
Atom 30	28	28	1424	1759	107.3	9549	7043	350	5076	387	364	489
	30	30	1526	1885	115.0	10231	7546	350	5076	352	355	476
	32.5	32.5	1653	2042	124.6	11084	8175	350	5076	315	345	462
	35	35	1780	2199	134.2	11936	8804	350	5076	310	365	490
	37.5	37.5	1907	2356	143.8	12789	9433	350	5076	281	355	476
Atom 40	40	40	2034	2513	153.4	13642	10062	350	5076	293	394	529

³⁾ Calculated as: Metric = Ts • (350-2) • 0,98

⁴⁾ The motors are designed according to DNV-rules. Test pressure 420 bar. Peak pressure 420 bar maximum, allowed up to 10 000 times.

⁵⁾ Flushing of motor case is required.

Motor type	Ø A		B		Ø C		D		E (splines)	Ø F		Weight		Main conn.	
	mm	in	mm	in	mm	in	mm	in		mm	in	kg	lbs		
Atom 10	300	11.81	225	8.86	256	10.08	58	2.28	DIN 5480 N70x3x30x22	279	10.98	52	115	1¼"	
Atom 20	300	11.81	265	10.44	256	10.08	58	2.28	DIN 5480 N70x3x30x22	279	10.98	68	150		
Atom 30	Front flange	300	11.81	317	12.47	256	10.08	70	2.76	DIN 5480 N100x3x30x32	279	10.98	88	194	
	Center flange	355	13.98	317	12.47	315	12.40	152	5.98	DIN 5480 N100x3x30x32	333	13.11	88	194	
Atom 40		355	13.98	357	14.04	315	12.40	152	5.98	DIN 5480 N100x3x30x32	333	13.11	102	225	

Häggglunds Atom 10, 20 (and 30 28 F, 30 30 F)

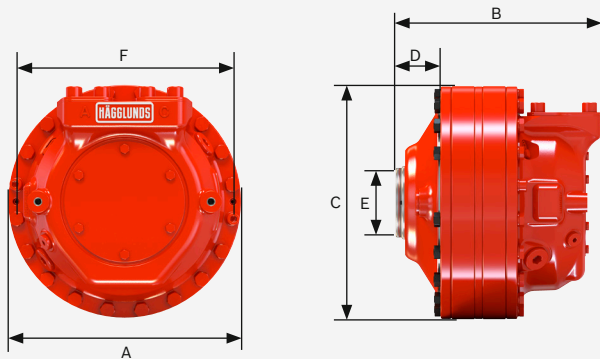

Häggglunds Atom 30, 40

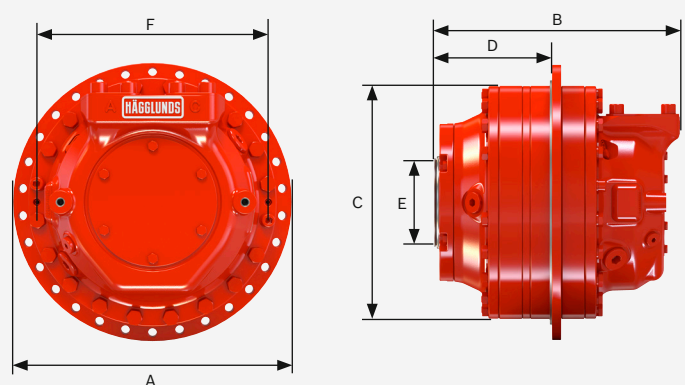

HÄGGLUNDS

Bosch Rexroth AB

SE-895 80 Mellansel
tel: +46 (0)660 870 00
www.hagglunds.com

Häggglunds is a brand of Rexroth, a leading global supplier of drive and control technologies. Häggglunds solutions enrich a comprehensive Rexroth portfolio.

Version No: 04.2023
Replaces: 02.2021
© Bosch Rexroth AG 2023

The data specified above only serve to describe the product. No statements concerning a certain condition or suitability for a certain application can be derived from our information. The information given does not release the user from the obligation of own judgment and verification. It must be remembered that our products are subject to a natural process of wear and aging.