

Application software eOC BODAS pump control



- ▶ Electronic control for open circuit pumps
- ▶ Release 100
- ▶ Software solution on Rexroth control unit SRC-eOC

Features

- ▶ Electronic interface for pump pressure, displacement and torque control
- ▶ Adjustable and variable dynamics
- ▶ Improved machine performance and productivity
- ▶ Less fuel consumption and optimized battery usage
- ▶ Reduced pump variance and service effort
- ▶ Integrated component calibration
- ▶ Easy application with commissioning tool for parameter optimization

Contents

1	Introduction	2
2	Typical applications and benefits	3
3	System description	4
4	Functional description	6
5	Electrical interfaces	9
6	Parameter setting and diagnostics	12
7	Functional safety considerations	12
8	Project engineering and ordering information	13
9	Valid standards and additional documentation	15
10	Abbreviations	16
11	General information	16
12	Security information	16
13	Safety instructions	17

1 Introduction

The portfolio of open circuit axial piston pumps from Bosch Rexroth provides a high variance of hydro-mechanical control functions with mechanical interfaces for machine optimization.

With the new electronic control concept eOC BODAS pump control all these functions and interfaces are now transferred into software.

The eOC software allows to electronically control the pressure, displacement and torque of an axial piston pump thus enabling customizable control modes and adjustable pump dynamics during operation.

For standard control, a predefined functions set is available on a dedicated Rexroth control unit SRC-eOC. The control unit processes sensor information such as pressure and displacement and calculates an output current to an electro-proportional pump control valve. Static and dynamic adaptations can be done via parameter calibration and/or via CAN bus commands.

All available control functions and possibilities for customization are described in this data sheet. For the implementation of additional customer specific functions, please get in touch with your Bosch Rexroth sales representative.

The eOC BODAS pump control is prepared to be applied to any kind of mobile working machine that requires an open circuit axial piston pump. Still, the maximum operating conditions of the installed axial piston pump, such as A10VO series 31, must be respected. For detailed technical information, please refer to the corresponding pump data sheet.

2 Typical applications and benefits

The eOC BODAS pump control is suitable for a wide range of mobile working machines requiring an open circuit axial piston pump – from construction, agricultural and forestry machines to municipal vehicles.

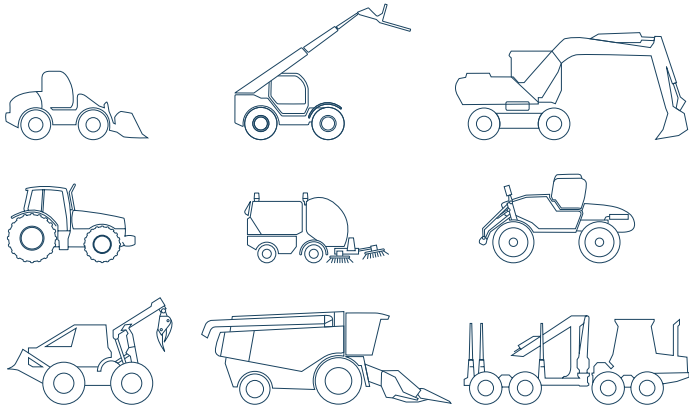

Each machine has different requirements towards the hydraulic system and its components. With eOC BODAS pump control the following major advantages can be achieved.

Adjustable and variable dynamics

Based on the need of dynamic adjustment of control parameters, the software can be differentiated into two variants:

- ▶ With the ENTRY variant of the eOC BODAS pump control software, the set values and parameters for each control mode can be pre-configured with fixed values via BODAS-service.
- ▶ The PREMIUM variant allows to dynamically adjust the set points via CAN bus interface, which opens up a wide range of additional functionalities and leads to an adaptable machine performance during operation.

Improved machine performance and productivity

Mobile machines are highly productive and optimized for their intended load cycles. At the same time, the installed engine power is limited. With the new eOC BODAS pump control software it is now possible to establish a direct communication between engine and axial piston pump to continuously and dynamically adapt the hydraulic power to the available engine torque. Further, the pump software is able to compensate disturbances (e.g. temperature,

speed) in machine load cycles, which allows highly dynamic operating functions with a high level of precision to increase the overall productivity of the machine.

Less fuel consumption & optimized battery usage

The control principle of an axial piston pump and how it interacts with the hydraulic system are two of the major aspects that affect the energy efficiency of a mobile machine. eOC BODAS pump control target is to optimize both. On the one hand, the consolidation of multiple controller axes for pressure, flow and torque into one results in a reduced fluid consumption of the pump control valve itself. On the other hand, the possibility to dynamically adjust control parameters, for instance in standby condition or during eco mode, allows to minimize the energy consumption of the overall hydraulic system.

Reduced pump variance and service effort

As all the different pump control types and mechanical settings of Rexroth axial piston pumps can be transferred into software, the number of pump configurations required for an OEM can be significantly reduced. This directly affects the effort of managing spare parts and aftermarket components and at the same time simplifies engineering work.

In the event of a malfunction or feature update the eOC BODAS pump control software can be maintained via the BODAS-service interface.

Further, BODAS-service provides a detailed guideline for efficient commissioning of the machine.

3 System description

The eOC BODAS pump control requires an electro-hydraulic control valve on the pump (“EC4”), described in the eOC pump data sheet e.g. 92705 (A10VO/32), a Hall-sensor for the pump swivel angle, see data sheet 95153 (SWS/20), and a pressure sensor on the pump outlet, see Rexroth data sheet 95156 (PR4 SENT).

In order to realize an electronic load sensing function, an additional pressure sensor for the load pressure has to be installed at the load sensing port of the main control valve. In order to realize an accurate pump flow control function, the pump speed has to be available on the CAN bus.

The eOC BODAS pump control software itself runs on a dedicated SRC-eOC, see Rexroth data sheet 95207, and processes the pressure, swivel angle and speed information to generate the current on the pump control valve. Without control current, the pump swashplate will stay at minimum displacement.

The command values for pressure, flow and torque control have to be communicated to the software either by fixed parameter settings or dynamically via CAN bus interface.

- ▶ **eOC BODAS pump control ENTRY** targets to substitute conventional hydro-mechanical pump control types and to harmonize pump control strategies for the OEM. In this variant, command values are pre-configured as fixed parameters (e.g. fixed working pressure limitation, fixed delta pressure, fixed torque, and fixed dynamics) and can be adjusted with the BODAS-service tool.
- ▶ **eOC BODAS pump control PREMIUM** targets to optimize and customize machine behavior and opens up a wide range of additional features for the OEM. In this variant, command values can be dynamically adjusted via CAN based SAE J1939 interface and are modifiable even during machine operation.

The CAN bus specification can be found in a separate document. Source addresses within the J1939 specification can be configured. Customer specific CAN protocol requirements are handled in a customer specific project on demand.

3.1 System overview

▼ Typical configuration for electrohydraulic pump control eOC BODAS pump control

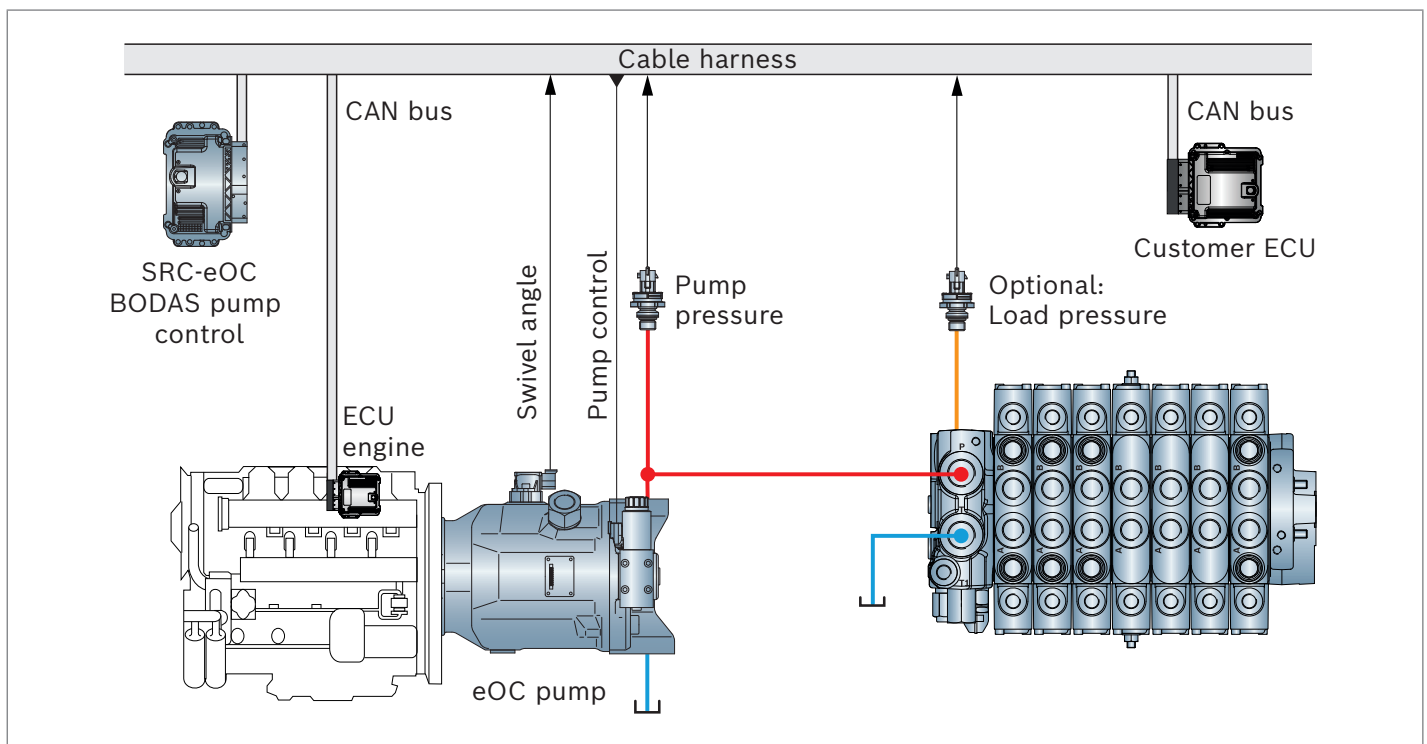

3.2 Pumps prepared for eOC control

The eOC BODAS pump control can be applied to various types of Rexroth variable displacement pumps in swash-plate design.

Prepared for series production:

- ▶ A10VO series 31 (92701) and series 32 (92705)

In preparation, available on request:

- ▶ A11V(L)O series 1x (92500)
- ▶ A15V(L)O series 12 (92512)

All pumps require an electro-proportional control valve (type "EC4") to realize the intended control function and a swivel angle sensor to feedback the actual displacement.

Please refer to the individual data sheets for detailed information about available configurations and operating limits.

3.3 SRC-eOC

The control unit SRC-eOC is designed as a special ECU to run the new electronic control concept eOC BODAS pump control.

The control unit SRC-eOC series 40 is technically identical to the RC5-6/40 with a reduced number of available inputs and outputs.

The SRC-eOC is only allowed to be used in combination with the platform application software ASrun-eOC100 and parameter variants of this software. This includes flashing and using the SRC-eOC exclusively with the application software ASrun-eOC100 and parameter variants thereof.

▼ Variable displacement pump A10VO series 32, prepared for eOC BODAS pump control

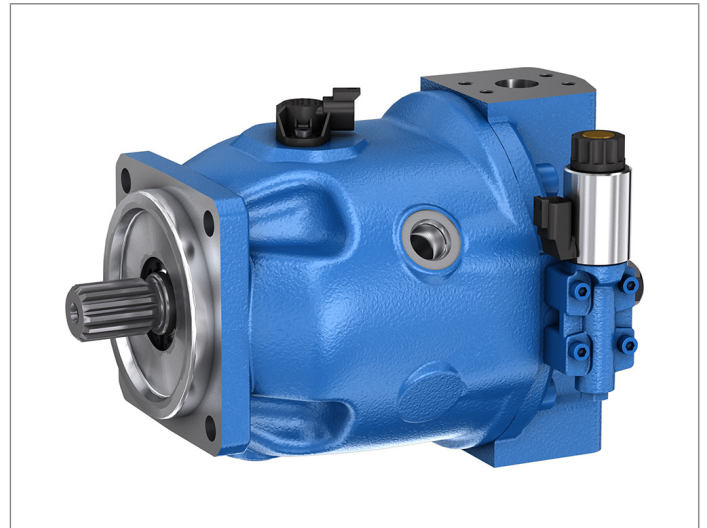

▼ SRC-eOC

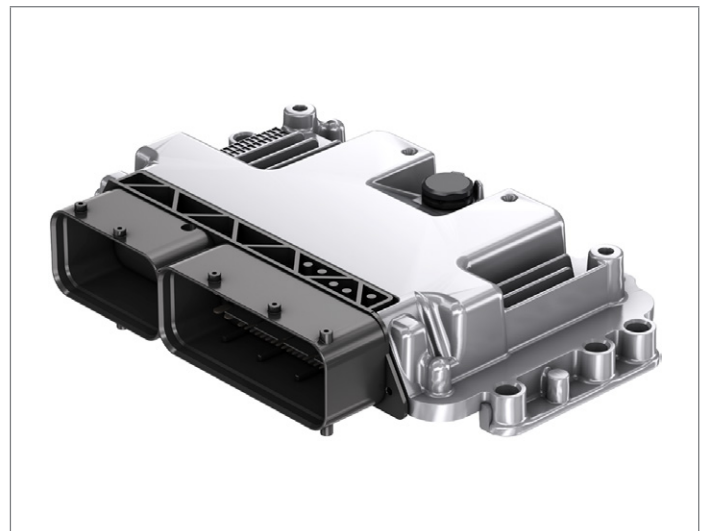

4 Functional description

The eOC BODAS pump control software supports all three main control principles of a swashplate axial piston pump.

- ▶ Pressure and delta pressure control
- ▶ Displacement and flow control
- ▶ Torque control

In addition to the main control parameters the software further allows to customize the dynamics of each control principle in order to adapt the pump behavior to the hydraulic system and machine dynamics.

- ▶ Pressure change rate
- ▶ Displacement and flow change rate
- ▶ Torque change rate

Enhanced software functions can be activated as AddOns in accordance with the chosen software configuration. Further, e.g. machine specific functions can be added on demand.

- ▶ Self-calibration cycle
- ▶ Load limiting control
- ▶ Cold start program
- ▶ Virtual minimum displacement
- ▶ Two instances of pump control in one control unit

4.1 Pump control functions and dynamics

Pressure and delta pressure control

The pressure control function allows to limit the pump pressure to a desired value and/or to achieve a constant pressure difference between load pressure and pump pressure (electronic load sensing – additional pressure sensor for load sensing required).

The command values for maximum pressure and delta pressure can be set via BODAS-service (ENTRY) or CAN J1939 command message (PREMIUM).

Displacement and flow control

The displacement control function allows to control the displacement or flow of an axial piston pump (pump speed to be communicated via CAN EEC1 message).

The command values can be set via BODAS-service (ENTRY) or CAN J1939 command message (PREMIUM).

Torque control

The torque control function allows to limit the maximum mechanical torque that the pump requires from the engine (pump efficiency map is considered in the algorithm). As soon as the input shaft torque exceeds the predefined limitation, the controller will reduce the pump displacement accordingly.

The command values for maximum input shaft torque can be set via BODAS-service (ENTRY) or CAN J1939 command message (PREMIUM).

Variable pump dynamics

The pump dynamics can be adjusted by limiting the derivatives of each control mode, e.g. maximum pressure change rate, maximum flow change rate and maximum torque change rate. With the PREMIUM variant the command values such as pressure gradient, flow gradient and torque gradient can be remotely set via CAN J1939 command message during operation.

Pump protection

The pump protection module prevents unfavorable operating conditions of the pump. It limits the maximum allowed pressure level according to data sheet information (e.g. default value 350 bar with A10VO) and limits the maximum allowed swiveling speed of the swashplate regardless of the main control functions.

Important: The maximum working pressure (e.g. 280 bar with A10VO) still has to be ensured via pressure control command.

Fail-safe behavior

Detailed failure numbers and pump reactions are described in the failure reaction table (see supporting documents in chapter 9)

The following failure types are detected:

- ▶ Sensor failure
- ▶ Solenoid failure
- ▶ Internal control unit failure
- ▶ Communication failure
- ▶ Start condition failure

Depending on the failure type, substitute values are used or the control is switched off and the pump acts according to its hydro-mechanical fall-back behavior.

Two instances of pump control in one control unit

The eOC BODAS pump control software includes two independent instances. Therefore up to two pumps can be controlled with all defined features independently.

4.2 Add-Ons available in ASrun

Self-calibration cycle

With the self-calibration AddOn the angle sensor information for maximum and minimum displacement is automatically recalibrated and stored at engine start. The feature allows to skip a manual calibration end of line and to compensate potential sensor drifts during the lifetime of the axial piston pump.

The calibration is skipped below 15 °C (parameter). In these cases the latest values from the persistent memory are used.

Impact on pump behavior:

- ▶ Pump is forced to maximum displacement during speeding up the pump for around 100 ms.
Background information: Due to spring forces it is set closed to maximum displacement anyway.
- ▶ Pump is controlled to minimum displacement by a defined pressure level after start up phase for around 150 ms. During calibration no pump flow is allowed (e.g. flushing valve) in order to reach the correct $V_{g\ Zero}$ position.
Additional hint: If mechanic $V_{g\ min}$ position is set, this position needs to be set as parameter in order to correctly extrapolate towards $V_{g\ Zero}$.

Load limiting control

With the load limiting control AddOn the torque limitation setpoint of the pump is automatically reduced as soon as a drop of the engine speed is detected. The feature provides a protection against engine stall and allows to minimize the impact of changing operating conditions (e.g. temperature, operating height, etc.). An electronic interface (e.g. CAN J1939) to engine ECU to communicate engine speed and load information is required.

- ▶ TSC1 message for nominal speed
 - ▶ EEC1 message for actual speed
 - ▶ EEC2 message for actual percentage load at current speed
- Dynamic availability of these is mandatory (e.g. 10 ms cycle time and low delay times).

Cold start program

With the cold start AddOn the eOC BODAS pump control software is able to manage the warm up phase of the axial piston pump. The feature limits the operating conditions in accordance to 90300-03-B ("Instructions on the Use of Hydrostatic Drives at Low Temperatures") as long as the fluid temperature level is below -25 °C. The fluid temperature can be monitored with the installed PR4 SENT pressure sensors. Usage of reservoir temperature information is possible on demand.

Virtual minimum displacement/flow

With the virtual minimum displacement AddOn the pump swashplate will be virtually stopped at a predefined minimum displacement. The feature supports several use cases, such as flushing of the main control valve, increased dynamics at start of movements, and standby management. This can be also configured for a virtual minimum flow, incorporating the pump speed. In contrast to a mechanical stop, the maximum pressure setting will override the minimum displacement setting. See Chapter 4.4.

4.3 Add-Ons available on demand

Hybrid operating mode

With the hybrid operating AddOn the eOC BODAS pump control software will be able to control the pump in the positive and additionally in the negative quadrant. Meaning, the pump will operate as a motor by swiveling the swashplate across zero into the negative quadrant. The motor operating mode may be used for hybrid systems with recuperation function or advanced system concepts. The feature can only be activated, if the pump hardware is prepared for two quadrant functionality. Please get in touch with your Bosch Rexroth sales representative to discuss about such solutions.

Advanced pump protection

The advanced self protection AddOn extends the functionality of the basic pump protection module. The feature, for instance, detects the occurrence of pressure peaks in the system and applies counter measures within the eOC BODAS pump control software.

Please get in touch with your Bosch Rexroth sales representative to discuss about such solutions.

Control of multiple axial piston pumps

In standard configuration the eOC BODAS pump control software is prepared to control the pressure, displacement, and torque of two axial piston pumps.

If more than two axial piston pumps shall be equipped with the eOC control please get in touch with your Rexroth contact. Multiple pumps can be controlled independently and require individual CAN commands.

4.4 Control priorities

Since several command values can be active at the same time an abstracted signal flow diagram shows the priority of the different control functions.

If activated, the virtual minimum displacement function has higher priority compared to the main control setpoints, but lower priority compared to the pressure limitation function within the pump protection module.

For commissioning purpose all setpoints, but also the control current to the solenoid can be bypassed via BODAS-service.

If activated, the self calibration cycle will always have the highest priority within the first few seconds after machine start.

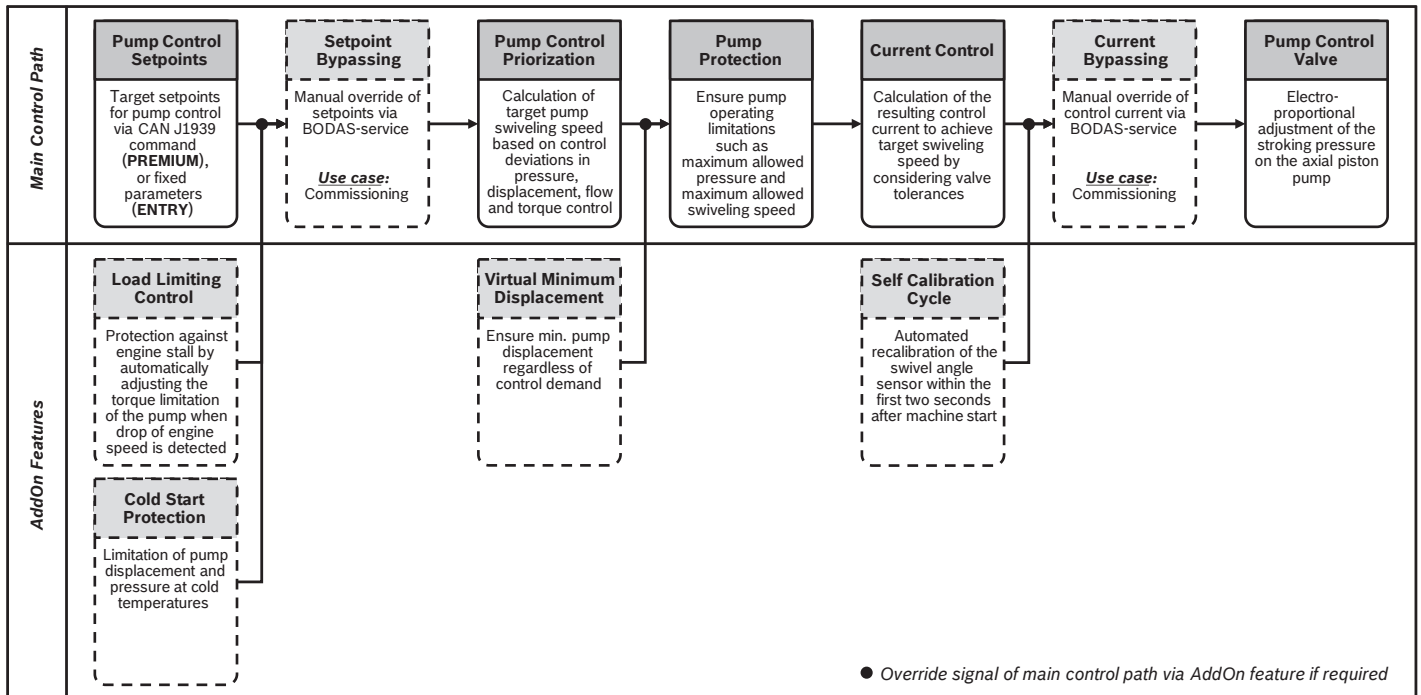

4.5 Electronic interfaces and functionality

System inputs

The following information is required to the control unit input to allow the full scope of eOC pump control functions:

Mandatory:

- ▶ Pump swivel angle
- ▶ Pump pressure

Optional:

- ▶ Load pressure
- ▶ Engine speed
- ▶ CAN commands

Note

The detailed hardware characteristics of the Rexroth control units are described in data sheet 95207. Please refer to this data sheet and read it carefully before using eOC BODAS pump control.

Using these inputs, the following functions are possible

Feature classification	ENTRY	PREMIUM	Inputs			
			Pump pressure	LS pressure	Swivel angle	Pump speed
Pressure control	fixed	remote	x		x	
Delta pressure control (electronic load sensing)	fixed	remote	x	x	x	
Flow control (flow rate)	o	remote			x	x
Displacement control	fixed	remote			x	
Torque control	fixed	remote	x		x	
Variable pump dynamics (only for PREMIUM)	o	remote				
Virtual minimum displacement		AddOn			x	
Self calibration cycle		AddOn			x	x
Load limiting control		AddOn	x		x	x
Cold start program		AddOn	x		x	

5 Electrical interfaces

5.1 General information

The connection diagram for standard wiring is shown in chapter 5.2. A separate document can be provided on demand.

The CAN bus protocol is prepared according to SAE J1939 and comprises the following information:

- ▶ Command values (PREMIUM)
- ▶ Status information
- ▶ Diagnostic trouble codes
- ▶ Additional Information to support the optimization of parameters. These can be switched on and off.

5.2 Connection diagram eOC BODAS pump control

Detailed information to the connection diagram can be found in data sheet 95207.

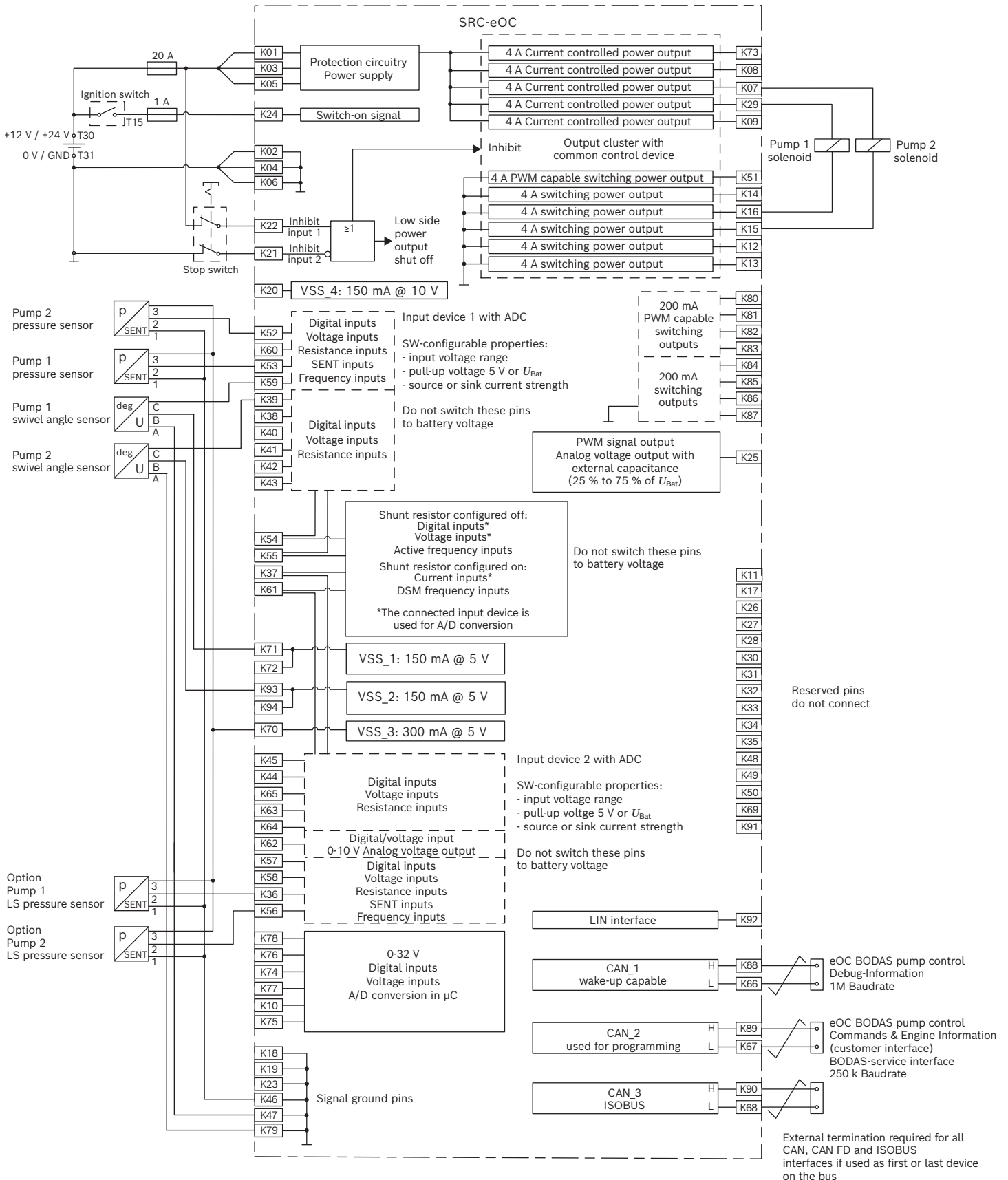

5.3 CAN signals

Up to three CAN channels are supported:

CAN_1	1000 kBaud	Debug messages
CAN_2	250 kBaud Default. Adjustable between 250 kBaud and 1000 kBaud on demand	Communication with engine ECU and BODAS- service (Command and status messages)

Input and output signals for the driver and machine interface are sent on CAN_2 in accordance with the SAE J1939 standard.

For details, see the CAN database (see supporting documents in chapter 9).

5.4 Solenoid output

The solenoid is controlled with a current between 0 and 2 A independent from the battery voltage level. No free wheeling diodes are allowed (since they are already part of the control unit and will influence the internal current measurement)

Due to shut off ability in short circuit situations, the solenoid current is fed back to the control unit.

5.5 Power supplies

Battery power supply

- ▶ 12 V and 24 V batteries are supported.
- ▶ The SRC control unit is using an after-run functionality. Therefore battery power supply must not be disconnected within a time period of 2 seconds after switching off ignition.

Sensor supplies

U_{Bat}

- ▶ This potential is connected to battery voltage and is protected by a fuse.
- ▶ It is solely used for power supply of ECU electronics and the emergency stop switch.

VSS_1, VSS_2, VSS_3

- ▶ This potentials is connected to 5 V constant voltage sources supplied by the ECU.
- ▶ It is used for sensors requiring a 5 V power supply.

6 Parameter setting and diagnostics

The parameters to be set during the commissioning can be easily adjusted using BODAS-service PC software.

BODAS-service could be configured to display the most important process variables and the error messages for fault diagnostics and troubleshooting purposes.

A list of all available parameters and guided commissioning information is available on demand.

Basic eOC BODAS pump control parameter view in BODAS-service

The screenshot displays the BODAS-service software interface. At the top, the Rexroth logo and 'A Bosch Company' are visible. The interface is divided into several sections:

- Navigation:** Includes icons for information, power, refresh, home, list, connection, settings, and help.
- Device Info:** Shows tabs for Parameters, Process Data, I/O, and Error Messages.
- Actions:** Buttons for Change Roles, Save to XML, XML to ECU, Save, Default, and Reset.
- Search:** A search bar with a search icon and a close button.
- Parameter Tree:** A sidebar with a tree view showing categories: 1 Basic Configuration, 2 HW I/O, 7 Pressure Control (PC), 9 Angle / Flow Control (AC), 11 Torque Control (TC), and 15 Bypassing (BYP). The 'Basic Configuration' category is expanded.
- Parameter List:** A table of parameters with sliders and input fields. The parameters are grouped into sections:
 - Basic Configuration > Machine:** 1.1.3 Power supply (12V, 1, none).
 - Pressure Control (PC) > PC Main:**
 - 7.1.1 PC main Kp (0,010): 0 to 10000, 1650, %/bar*s
 - 7.1.2 PC main Ki (0,001): 0 to 10000, 642, %/bar*s
 - 7.1.3 PC main Kdamp (0,001): 0 to 32000, 55, %/bar
 - Angle / Flow Control (AC) > AC Main:**
 - 9.1.1 AC main Kp (0,010): 0 to 10000, 2000
 - 9.1.2 AC main Kdamp (0,001): 0 to 32000, 1009
 - Torque Control (TC) > TC Main:**
 - 11.1.1 TC main Kp (0,010): 0 to 10000, 4057, %/Nm*s
 - 11.1.2 TC main Kdamp (0,001): 0 to 32000, 0, %/Nm
- Buttons:** SELECT ALL, EXPAND ALL, DESELECT ALL, COLLAPSE ALL.

7 Functional safety considerations

eOC BODAS pump control transfers hydro-mechanical pump control functions into software. Therefore, no safety functions are foreseen or implemented. This assumption should be confirmed by the system design in combination with a hazard analysis and risk assessment.

Safety functions for safety relevant movements must still be realized within the hydraulic circuit, independently of the pump behavior.

If the pump control function shall be part of a safety function, please contact your sales representative for further information.

8 Project engineering and ordering information

8.1 Ordering code

01	02	03	04
SRC-eOC	+	ASrun	- eOC 100

Hardware

01	Special Rexroth control unit electronic open circuit	SRC-eOC
----	--	----------------

Type

02	Application software	ASrun
----	----------------------	--------------

Function

03	The functional scope is specified. It covers a superset of all functions described in this datasheet.	eOC
----	---	------------

Release

04	Release number of the software	100
----	--------------------------------	------------

The eOC BODAS pump control will be delivered flashed on a Rexroth control unit SRC-eOC

When placing an order, the hardware and software ordering codes are to be linked by a “+”.

Reference ordering code: SRC-eOC + ASrun-eOC100.

8.2 Starter kit eOC prototype

In order to facilitate the first installation of eOC BODAS pump control on a new prototype machine, a pre-composed starter kit package is available with Rexroth part number R9017014438.

The starter kit comprises the following contents:

SRC-eOC control unit

- ▶ ASrun-eOC100 application software
- ▶ Lab-Wiring for RC series 40
- ▶ CAN-USB interface
- ▶ BODAS-service 4.x PC software
- ▶ BODAS-service USB dongle license

An initial set of control parameters can be provided on demand.

8.3 Project engineering

Project engineering is supported by a dedicated **project questionnaire**. The questionnaire supports the preparation stage of a new application project and helps to collect and to define the following project data:

- ▶ eOC BODAS pump control components and sensors
- ▶ Machine data
- ▶ Software features
- ▶ Rexroth project services
- ▶ Target machine characteristics

8.4 Project specific parameters

In the target application it is required to calibrate and optimize software parameters for the eOC BODAS pump control function. Some parameters are related to the used target pump some of them depend on the required control mode, some of them are related to the project specific communication and some of them need to be optimized in order to reach the desired (dynamic) machine behavior.

The process to find these parameters is described in a **Commissioning Guide** which can be requested from the responsible sales representative.

Rexroth offers support to calibrate the eOC BODAS pump control software in the target application on demand. As soon as the final set of parameters is found and shall be applied for series production, there are several options for end of line product handling at the machine manufacturer:

- ▶ Request a specific binary file that already contains the chosen parameters and can be directly flashed EOL.
- ▶ Request a customer specific, ready to use SRC control unit with the chosen parameter settings. A own order number will be available for each customer specific SRC. Please contact your sales representative to define the required option to handle the parameters.

8.5 Required tools

- ▶ BODAS-service 4.3.0 or higher; for the latest version, see www.boschrexroth.com/mobile-electronics
- ▶ CAN Analysing tool for commissioning or similar tool for CAN data commissioning
- ▶ Microsoft Excel or equivalent for handling the approval test specification

8.6 Recommended tools

- ▶ Vector CANalyzer Pro version 7.6 or higher

8.7 Documents and tools container

To assist in handling the product properly, a documents and tools container contains the following files and useful documentation:

- ▶ Test specification example file for approval test
- ▶ CAN database of proprietary SAE J1939 messages
- ▶ CANalyzer configuration

The complete list of container contents are summarized in Chapter 9.

The operating instructions as well as the valid standards and separate documentation must be considered before the software is used.

The documents and tools container is provided upon request via Info.Bodas@boschrexroth.de
Please use the following subject for your e-mail request:
"Container request: SRC-eOC + ASrun-eOC100"

Please also provide the following information:

- ▶ Company name
- ▶ Contact person
- ▶ E-mail address

8.8 Ordering process

The application software eOC BODAS pump control is provided as a standard ASrun product on a Rexroth control unit SRC-eOC.

In order to run the software on the machine a separate xml file with an initial set of parameters is required (configuration via Project Questionnaire).

The parameters can be optimized on the machine using BODAS-service. For commissioning support, please refer to the commissioning guide or get in touch with your Rexroth sales representative for on-site or remote support.

After all parameters and features are validated on the machine, the final set of parameters can be integrated into a machine specific .hex-file. This file will be saved as a standard configuration for the intended machine and can be flashed for series production see Chapter 8.4.

If a combination with other BODAS application software products (e.g. multiple eOC instances, eDA, AFC, ...) or customer-specific software is required, the eOC software can be provided with an ASopen approach. Compensation of project specific efforts must be considered.

For high quantity projects also an ASlib format is supported. However, the performance of the intended third party ECU must meet the determined requirements of the eOC software (e.g. cycle time). A prior prototype validation on a SRC-eOC is recommended to ensure full functionality. Project specific license agreements must be put in place individually.

Relevant part numbers for adjacent electronic components

All electronic components must be ordered separately. Please find below list of required part numbers.

Components	Part number	Plant	Data sheet
Starter kit eOC (for prototypes)	R917014438	Horb	RE 95345
SRC-eOC + ASrun-eOC100 ¹⁾	R917014452	Horb	RE 95207
PR4 SENT	see data sheet for detailed configuration	Horb	RE 95156
Connector kit RC5-6/40 (only connector)	R917010843	Horb	RE 95207
Connector kit RC5-6/40 incl. wiring 1.5 m	R917013283		
Connector kit PR4	R917009890	Horb	RE 95156
Connector kit angle sensor	R902603524	Horb	RE 95153 / 95150
Connector kit EC4	R902601804	Horb	pump data sheet

1) Included in Starter Kit

9 Valid standards and additional documentation

▼ Valid standards

Additional documents explaining normative and project-specific regulations are listed in the following tables.

Document	
SAE J1939-21 December 2010	Data Link Layer
SAE J1939-71 May 2012	Vehicle Application Layer
Standard DIN ISO 13849-1:2006-11	Safety of machinery – Safety-related parts of control systems
Standard DIN ISO 13849-2:2012-10	Part 1: General principles for design Part 2: Validation
SAE J2716 January 2010	Single Edge Nibble Transmission (SENT) protocol

▼ Supporting documents in container of chapter 8.7

Document	
Calibration Guide	Step by step support information to optimize the software parameters for the eOC BODAS pump control functions
BODAS-service App	Service App for ASrun to run in BODAS service for diagnostics and parametrization
Wiring schematic	Standard wiring for ASrun
Test specification	Template for machine tests with eOC pump for series release
Failure reaction table	Fault detection and fail safe reactions
CAN specification	J1939 CAN specification for ASrun customer interface
CAN DBC	CAN database to import the communication specifications into a CAN tool
CANalyzer configuration	Standard configuration to ensure proper arrangement of signals

▼ Compatible Rexroth products

Document	Data sheet	Comments
Axial piston variable pump A10V(S)O/31	92701	with eOC pump valve (EC4) and swivel angle sensor configuration
Axial piston variable pump A10VO/32	92705	with eOC pump valve (EC4) and swivel angle sensor configuration
Axial piston variable pump A11V(L)O/1x	92500	with eOC pump valve (EC4) and swivel angle sensor configuration
Axial piston variable pump A15V(L)O/12	92512	with eOC pump valve (EC4) and swivel angle sensor configuration
BODAS pressure sensor PR4	95156	PR4 420 XX B SE/10 PR4 280 XX B SE/10
Hall-effect swivel angle sensor SWS series 20	95153	Sensor to be specified for A10VO and A11VO pumps
Hall-effect swivel angle sensor SWS20 series 03	95150	Sensor to be specified for A15VO pumps
Rexroth control unit SRC-eOC series 40	95207	RC5-6/40 Note: The control unit SRC-eOC series 40 is technically identical with a reduced number of available in- and outputs. Therefore, this document is applicable as valid hardware data sheet.
BODAS-service 4.x	95087	BODAS service tool
BODAS-service connection cable	95087	Wiring harness to establish CAN communication to BODAS-service
BODAS measuring adapter MA6	95090	For checking of wiring harness
CAN-USB interface	95087	Device to establish the CAN communication between RC and PC
Diagnostics socket	95087	

10 Abbreviations

Abbreviation	Meaning
ADC	Analog digital converter
AS	Application software
BODAS	Bosch Rexroth digital application solutions
CAN	Controller area network
CAN-FD	Controller area network - Flexible data rate
DIN	Deutsches Institut für Normung (German Institute for Standardization)
ECU	Electronic control unit
EN	European norm
eOC	Electronic open circuit
EOL	End of line
GCC	GNU Compiler Collection
GND	Ground
ISO	International organization for standardization
JTAG	Joint test action group
LIN	Local interconnect network
LS	Low-side
OEM	Original equipment manufacturer
PC	Personal computer
PKCS	Public-Key Cryptography Standards
PWM	Pulse-width modulation
RC	Rexroth control unit
RSA	Rivest-Shamir-Adleman
SAE	Society of automotive engineers
SENT	Single edge nibble transmission
SRC	Special Rexroth control unit
XCP	Universal measurement and calibration protocol

12 Security information

Security elements are

Machine control unit sending commands to the SRC-eOC CAN bus, Service tool BODAS-service

Product security

- ▶ Security relates to enforcing policies to prevent changes in systems by unauthorized personal.
- ▶ The BODAS-service protocol provides security mechanism to prevent malicious manipulation of configuration or runtime behavior.
- ▶ Critical BODAS-service protocols/services require authentication.
- ▶ Since the software contains authentication data, all software artefacts should be handled confidential.
- ▶ For security reasons it is necessary to change all passwords of all levels!

11 General information

Legal information, software license agreement

The „General Terms and Conditions of Deliveries and Services by Bosch Rexroth AG” shall apply.

Link: <https://www.boschrexroth.com/en/xc/home/legal>
This product contains Open Source Software in the following form:

Libgcc, Copyright (C) 1989, 1992, 1993, 1994, 1995, 1996, 1997, 1998, 1999, 2000, 2001, 2002, 2003, 2004, 2005, 2007, 2008, 2009, 2010 Free Software Foundation, Inc. licensed under the GNU General Public License v3.0 with GCC Runtime Library exception 3.1.

This is a copyright indication not related to any license obligations.

Certain software functions are derived from the RSA Security Inc. PKCS #11 Cryptographic Token Interface (Cryptoki).

This indication has no relevance for the usage of this product.

The complete license information is available on demand.

- ▶ ECU-reset requests via BODAS-service shall not result in a critical machine situation
- ▶ XCP (CAN_3) for debugging shall be disabled by default in series machines via parameter (additionally XCP is disabled always after 24h machine hours at next ignition off/on)
- ▶ Rexroth assumes, that the RCs are not connected via unprotected 3rd party connectivity devices to the internet in series production. Particularly the integrity of the CAN communication is not protected by protocol measures. This means willful manipulation of CAN messages cannot be detected, which may compromise the functional safety goals of the vehicle. Blocking of CAN communication (Denial-of-service attacks) cannot be prevented by the system inherent bus layout of the vehicle.

Remaining risks

- ▶ Manipulation or spoofing of CAN messages cannot be detected.
- ▶ Usage of this product shall hence be limited to private CAN networks without public accessibility. It is the responsibility of the machine manufacturers to implement CAN segregation accordingly.
- ▶ The J1939 protocol by itself provides no security mechanism to prevent malicious manipulation of configuration or runtime behavior.
- ▶ All J1939 protocols/services can be used without prior authentication.
- ▶ The RCs are equipped with a JTAG interface (used by Rexroth for analysis of defect ECUs returned from field). The interface can be used by experts (after opening the housing) for manipulation or extraction of software and/or parameters.

13 Safety instructions

- ▶ THE SOFTWARE represents a safety element out of context (SEooC). The machine manufacturer must verify whether it is the right product for the specific application.
- ▶ The machine manufacturer must perform a risk assessment.
- ▶ The required safety functions and performance levels must be fulfilled with the product in order to use THE SOFTWARE in a specific application.
- ▶ The machine manufacturer bears responsibility for applying the valid safety standards at the machine level.
- ▶ The machine manufacturer is responsible for fulfilling all safety requirements at the hydraulic circuit and machine level.
- ▶ The machine manufacturer is responsible for validating the machine-specific configuration of THE SOFTWARE.
- ▶ Configurations of THE SOFTWARE used for serial production must be validated.
- ▶ The proposed circuits do not imply any technical liability for the system on the part of Bosch Rexroth.
- ▶ Incorrect connections could cause unexpected signals at the outputs of the RC.
- ▶ Incorrect programming or parameter settings may create potential hazards while the machine is in operation.
- ▶ It is the responsibility of the machine manufacturer to identify hazards of this type in a hazard analysis and to bring them to the attention of the end user. Bosch Rexroth assumes no liability for dangers of this type.
- ▶ The application software must be installed and removed only by Bosch Rexroth or an authorized partner to pre-serve the warranty.
- ▶ It must be ensured that the vehicle is equipped with adequately dimensioned service and parking brakes.
- ▶ Make sure that the software configuration does not lead to safety-critical malfunctions of the complete system in the event of failure or malfunction. This type of system behavior may put life in danger and/or cause great damage to property.
- ▶ System developments, installations and commissioning of electronic systems for controlling hydraulic circuits must only be carried out by trained and experienced specialists who are sufficiently familiar with both the components used and the complete system.
- ▶ The machine may pose unforeseen hazards while commissioning and maintenance are carried out. Before commissioning the system, you must therefore ensure that the vehicle and the hydraulic system are in a safe condition.
- ▶ Make sure that nobody is in the machine's danger zone. No defective or incorrectly functioning components may be used. If the components should fail or demonstrate faulty operation, repairs must be performed immediately.
- ▶ The technical specifications and safety instructions of all involved components must be considered.
- ▶ The machine manufacturer must follow the valid standards and separate documentation when using the product.

Intended use

- ▶ The control unit is designed for use in mobile working machines provided no limitations/restrictions are made to certain application areas in this data sheet.
- ▶ Operation of the control unit must generally occur within the operating ranges specified and released in this data sheet, particularly with regard to voltage, current, temperature, vibration, shock and other described environmental influences.
- ▶ Use outside of the specified and released boundary conditions may result in hazard to persons and/or cause damage to components which could result in sub sequential damage to the mobile working machine.

Improper use

- ▶ Any use of the control unit other than as described under “Intended use” is considered to be improper.
- ▶ Use in explosive areas is not permissible.
- ▶ Damage resulting from improper use and/or from unauthorized interference in the component not described in this data sheet render all warranty and liability claims void with respect to the manufacturer.

More detailed information

- ▶ Observe the operating instructions for the product
- ▶ The safety measures are to be observed
- ▶ In addition, the application-specific documents (connection diagrams, software descriptions, etc.) are to be observed.
- ▶ More detailed information on BODAS control units and software products may be found at www.boschrexroth.com/mobile-electronics.
- ▶ Pay regular visits to our home page for the latest product information and information about updates.
- ▶ Copying, translation and distribution of Bosch Rexroth software is prohibited under copyright law.

Bosch Rexroth AG

Robert-Bosch-Straße 2
71701 Schwieberdingen
Germany
Service Tel. +49 9352 40 50 60
info.bodas@boschrexroth.de
www.boschrexroth.com

© Bosch Rexroth AG 2021. Alle Rechte vorbehalten, auch bzgl. jeder Verfügung, Verwertung, Reproduktion, Bearbeitung, Weitergabe sowie für den Fall von Schutzrechtsanmeldungen. Die angegebenen Daten dienen allein der Produktbeschreibung. Eine Aussage über eine bestimmte Beschaffenheit oder eine Eignung für einen bestimmten Einsatzzweck kann aus unseren Angaben nicht abgeleitet werden. Die Angaben entbinden den Verwender nicht von eigenen Beurteilungen und Prüfungen. Es ist zu beachten, dass unsere Produkte einem natürlichen Verschleiß- und Alterungsprozess unterliegen.