

## TS 2pv – Gentle, Clean, Efficient. Ideal for Module Production

Transfer system for the solar industry



# Rexroth – we bring movement to module production

Whether wafer-based solar modules or thin-film technology modules – production of these products is an extremely sensitive and complex process that consists of numerous processing steps, and also places the highest demands on material transport before, during, and after the individual processing stations.

The glass plates are not only relatively large and extremely fragile, but also extremely sensitive to contamination. This is why Rexroth has developed a special transfer system that takes these high demands into consideration and is characterized by high efficiency: the TS 2pv.

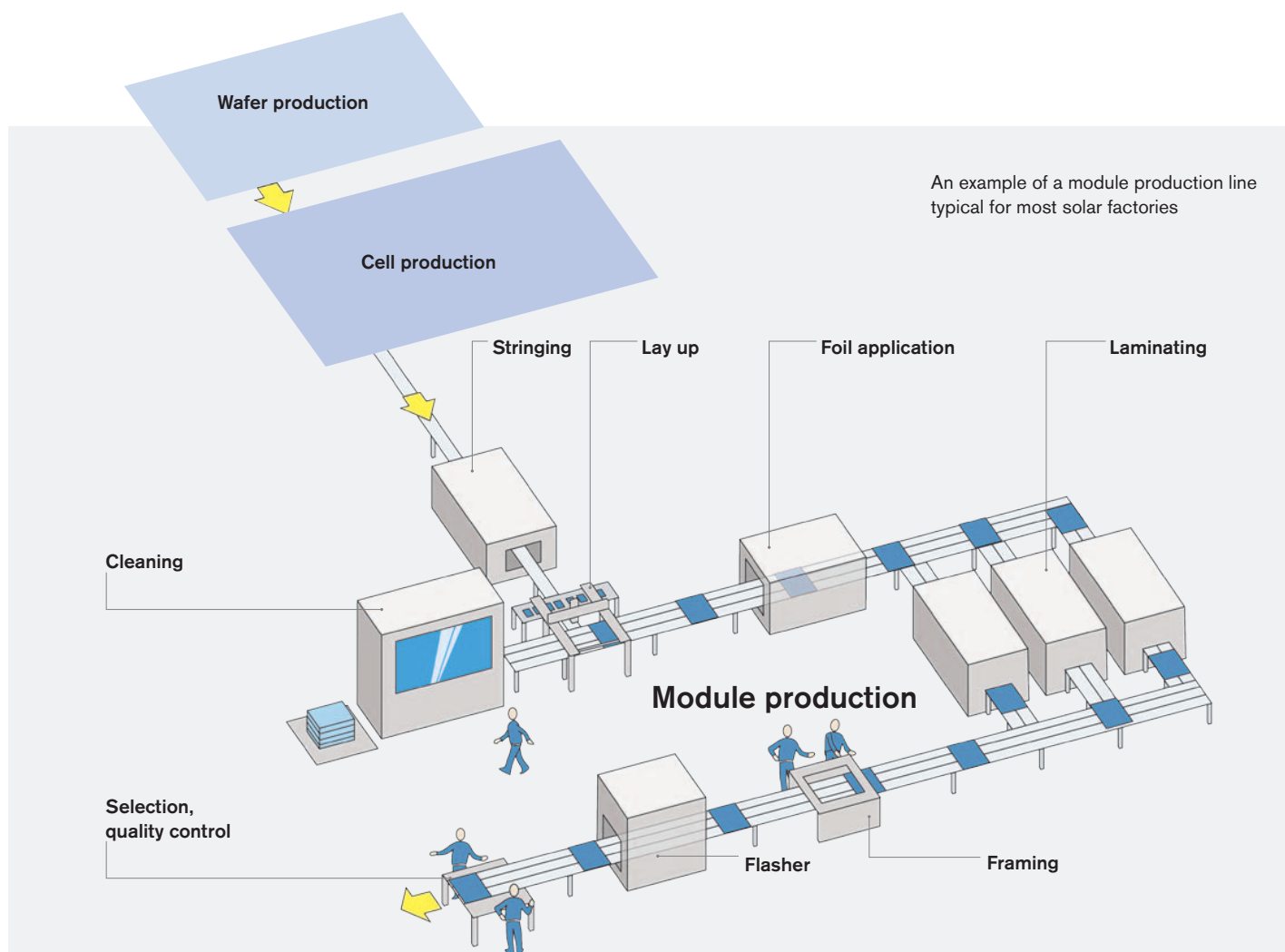



Temperature-resistant belt section in multi-track design

### Ideal for gentle material flow

The production process for solar modules demands jolt and vibration-free transport without accumulation operation. To accomplish this, the TS 2pv conveyor sections are divided into short segments:

- Depending on the respective module dimensions, the individual segments are usually two to three meters long, 0.6 to 1.5 meters wide, and are made of two to four tracks
- Each segment has its own drive
- The drive stops to position the module for processing or if the following section segment is still occupied by another module
- Frequency converters ensure soft braking and accelerating
- The TS 2pv lift transverse unit gently moves the modules from longitudinal sections to transverse sections

### Created for clean production

A clean production environment plays a decisive role when manufacturing modules, as this is the only way to ensure a uniformly high product quality. As a result, suitability for clean rooms was at the forefront during the development of the TS 2pv and associated components.

- Fulfills the requirements for clean room class 6 in accordance with EN ISO 14644-1
- No contamination by silicone, grease, or oil
- Almost fully wear-resistant toothed belts with an extremely tight textile coating and singed edge
- Fully ESD-compatible version to avoid electrostatic discharge, which prevents the attraction of dust particles

### A hot tip for hot plates

To transport glass plates with temperatures of up to 200°C, we also offer temperature-resistant solar conveyors. These can be implemented with any number of tracks, depending on the number of solar panels. Special features:

- Toothed belts and heat-resistant guide profiles
- Hexagonal shaft and flange for TS gear motors
- Integrated toothed belt tensioner

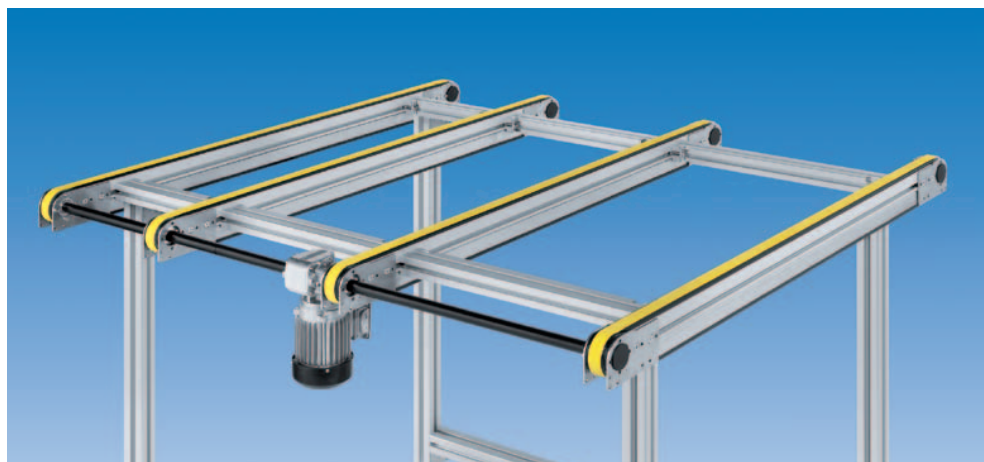

Four-track version of a single TS 2pv belt section segment with one drive

# Powerful and flexible – assembly solutions for the solar industry

For wafer, cell, or module production – Rexroth brand systems and components are used in the most varied production areas and processes. In addition to transfer systems, we also offer individually configurable handling systems, Manual Production Systems, control technology, and basic mechanical elements for all kinds of

applications and tasks.

## Manual Production Systems for efficient manufacturing

Manual Production Systems ensure fast throughput times and high product quality in many manufacturing processes. Besides a wide product range including e.g. lighting systems for quality control, we also offer expert advice and solutions for the following areas:

- Ergonomics
- 5S workstation organization
- Process optimization
- Lean production systems

## The legendary aluminum modular profile system

Includes universal components for constructing frames, appliances, work tables, safety equipment, and protective barriers. Standardized, aluminum strut profiles, a wide range of sturdy and detachable connections, and versatile accessories make this modular profile system extremely flexible.



Rexroth – technology and know-how for lean production systems

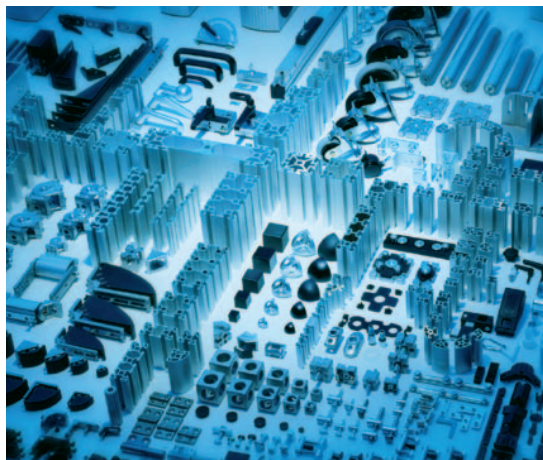

The aluminum modular profile system contains over 1,500 individual components and more than 100 profile cross sections

Special demands require customized solutions. This is why the TS 2pv transfer system has been consistently adapted to product and process-specific features in the solar industry. The basis of this is our "classic" transfer technology that has proven itself in the most varied industries.

Individual systems can be implemented very quickly and inexpensively through the use of numerous standard components. All of this, of course, in Rexroth's well-known quality and with comprehensive, worldwide service.

This also includes individual consultation on how to configure your TS 2pv transfer system.



The TS 2pv conveying solar modules between two processes. The lift transfer unit moves the modules from the longitudinal section to the transverse section.

Bosch Rexroth AG  
Linear Motion and  
Assembly Technologies  
Postfach 30 02 07  
70442 Stuttgart, Germany  
Tel. +49 711 811-30698  
Fax +49 711 811-30364  
[www.boschrexroth.com/dcl](http://www.boschrexroth.com/dcl)

**Find your local contact person here:**  
[www.boschrexroth.com/addresses-dcl](http://www.boschrexroth.com/addresses-dcl)