

# ActiveMover transfer system

1.0



# Symbols

## Potential applications

---



Suitable for use in clean rooms

---

## Product features

---



Magnetic

---

<b>ActiveMover transfer system</b>	<b>1</b>
<b>Workpiece pallet</b>	<b>2</b>
<b>Sections</b>	<b>3</b>
<b>Base frame</b>	<b>4</b>
<b>Power supply</b>	<b>5</b>
<b>Control</b>	<b>6</b>
<b>Tools</b>	<b>7</b>
<b>Material numbers overview, index</b>	<b>8</b>





# ActiveMover transfer system

1

<b>ActiveMover – features</b>	<b>1-3</b>
<b>Operating principle</b>	<b>1-5</b>
<b>Uses and applications</b>	<b>1-6</b>
<b>Configuration and commissioning</b>	<b>1-8</b>
<b>Components</b>	<b>1-10</b>



# ActiveMover – the transfer system for high-speed applications

The ActiveMover transfer system by Rexroth can be used wherever products have to be transported with speed and precision.

High speed, rapid acceleration and a low-friction, magnetic clutch help reduce cycle time. Workpiece pallets can be moved independently to any defined position, even along curves, at a wide range of acceleration rates and speeds smoothly and with precision. All this while also remaining easily accessible, giving you maximum accessibility to the workpiece.

In addition, sections can be added on as needed, making it a snap to expand with more stations.

The free programming and control of each individual workpiece pallet allows entire sequences of processes to be implemented with ease. The system can even operate in reverse, as well as in asynchronous and synchronous modes.

## Benefits from its special features

- ▶ **Precise:** Exact workpiece pallet positioning without additional indexing
- ▶ **Fast:** Shorter cycle times through high speed and acceleration, faster workpiece pallet changeover
- ▶ **Robust:** Powerful drive up to 160 N per workpiece pallet plus a solid design—for the simplest process integration and a wide range of uses
- ▶ **Flexible:** Standard industrial controllers can be connected; every workpiece pallet is freely programmable and quickly convertible



# ActiveMover – precise, fast, robust and flexible

## Precision

Exact workpiece pallet positioning without additional indexing. Workpiece pallets are automatically moved to any position with precision, even along curves. This not only increases process quality, it also improves your productivity and, with it, your profitability.

## Speed

The low-friction, magnetic clutch between linear drive and workpiece pallet helps achieve high speeds and rapid acceleration. In addition, no time is lost from stopping, positioning and adjusting. Benefit from reduced cycle time and increase your productivity while lowering costs.

## Robustness

A powerful drive moves workpiece pallets weighing up to 10 kg with up to 160 N. The bores in the sturdy base frame allow specific work stations or enclosures to be directly integrated, making the ActiveMover transfer system highly versatile.

## Flexibility

Save on costs by covering the majority of your manufacturing processes with one system and standardizing your production facility. The following operating modes are available: reverse, asynchronous and synchronous.

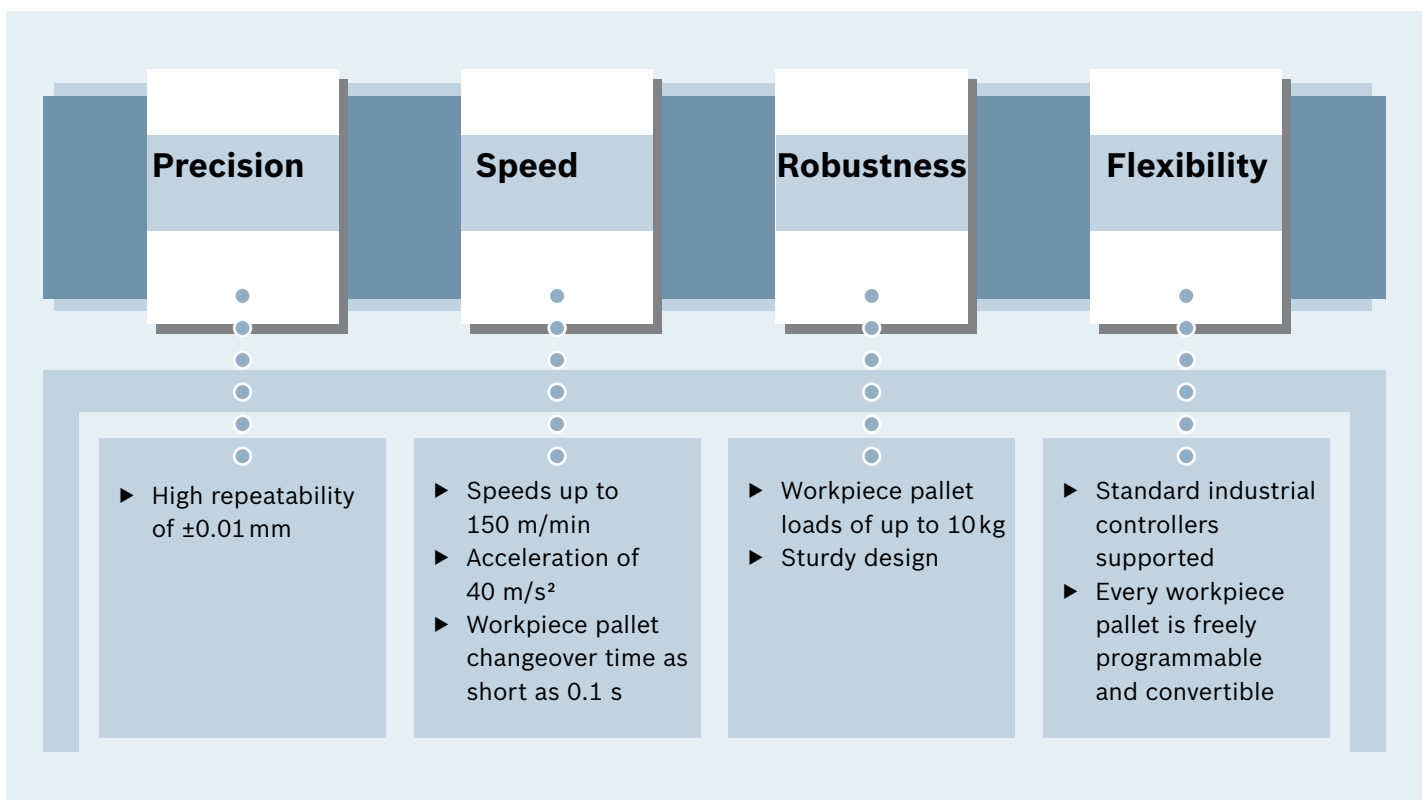



# ActiveMover – the solution for high product variety or sensitive materials

## Operating principle

The basic layout of the Rexroth ActiveMover transfer system consists of straight sections and 180° curved sections with vertically installed, low-wear linear motors. Workpiece pallets travel to precisely defined positions independently of one another, sometimes even to several consecutive positions within a single station. Parts are processed on your product fixture, which is mounted to the workpiece pallet. For precise control, a unique number can be stored on an optional data carrier mounted to each workpiece pallet. Once the workpiece pallet passes the reading station, the data carrier is read at full speed (150 m/min) and acceleration (40 m/s<sup>2</sup>).

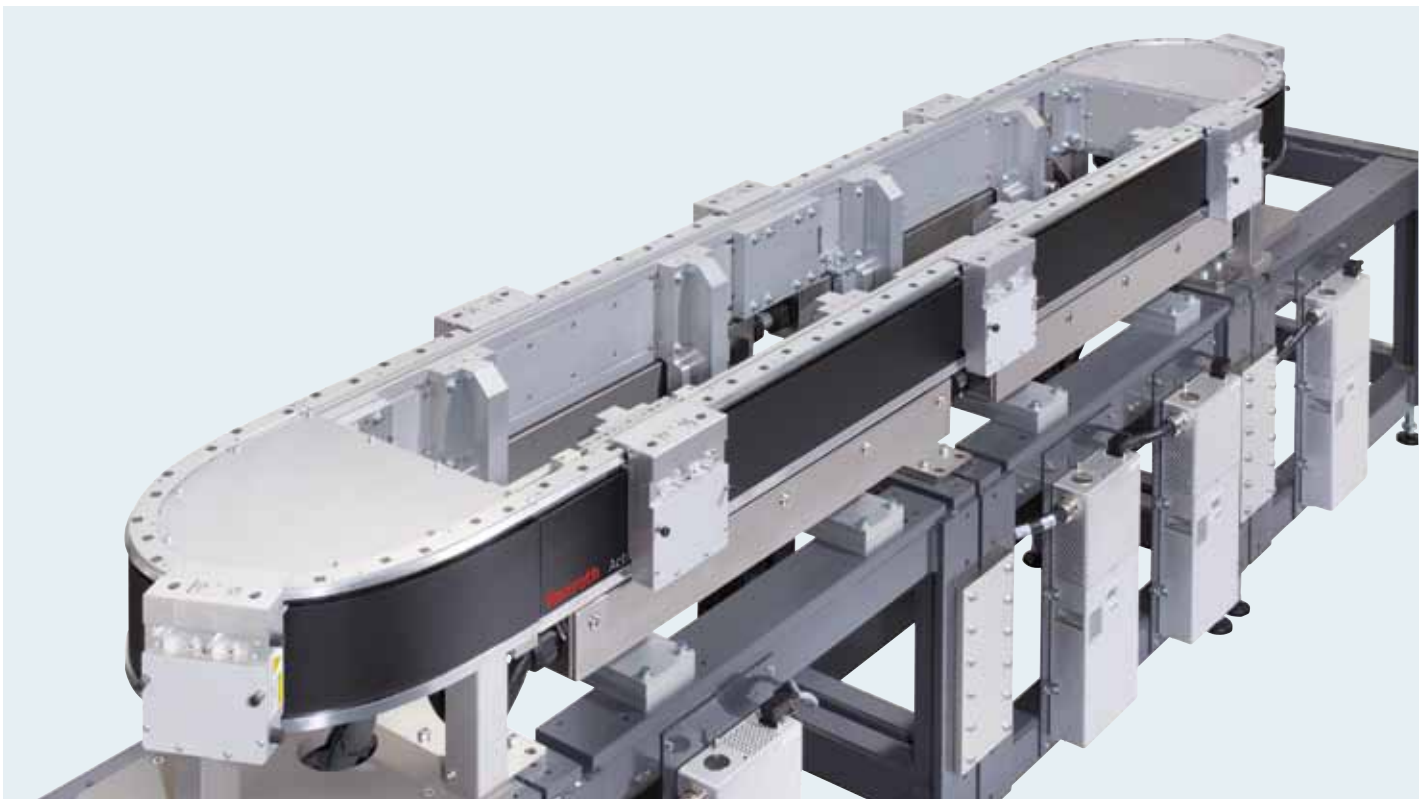
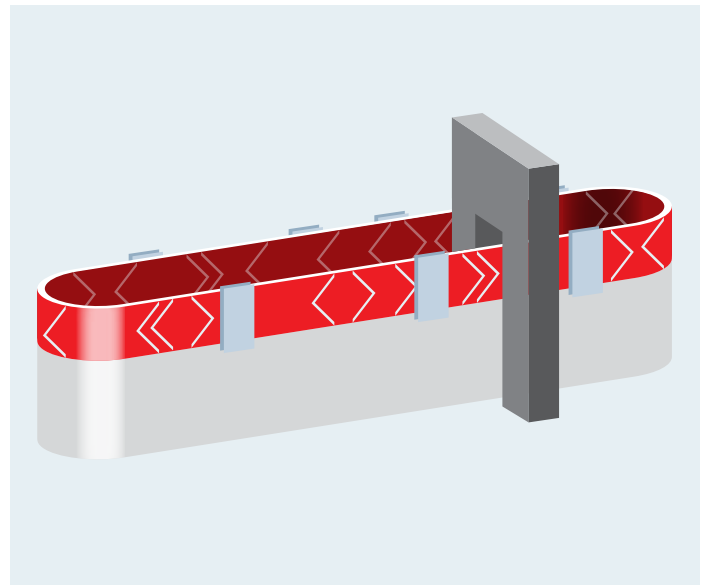

# ActiveMover – uses as versatile as its applications

## Practical flexibility – versatile uses



### Precise

- ▶ Electronics boards
- ▶ Controllers
- ▶ Glucose test strips and lancets
- ▶ Door lock actuators
- ▶ Syringe needles
- ▶ Catheters
- ▶ Inhaler dose meters
- ▶ Blood collection devices



### Fast

- ▶ Colored pencils
- ▶ Contact lenses
- ▶ Disposable razors
- ▶ Hygiene products
- ▶ Spray nozzles
- ▶ Cell phones
- ▶ Spark plugs
- ▶ Injectors
- ▶ Lipsticks

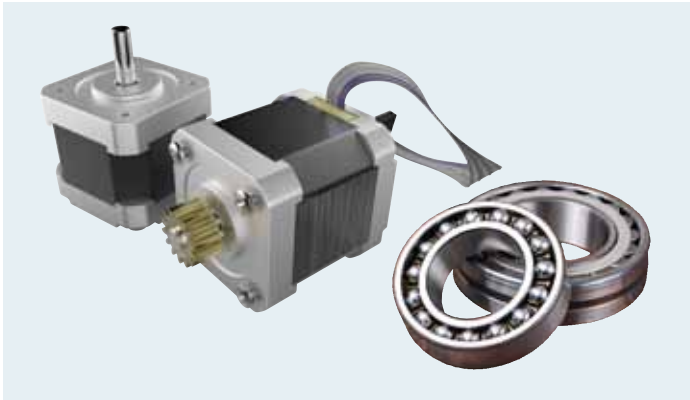

### Robust

- ▶ Dry food filling and packaging
- ▶ Guide rails
- ▶ Roller bearings/sleeve bearings
- ▶ Control units
- ▶ Servo motors
- ▶ Wiper motors



### Flexible

- ▶ Cell phones
- ▶ LED lights
- ▶ ABS/ESP valves
- ▶ Fuse holders
- ▶ Hinges
- ▶ Valve assembly
- ▶ Dry food filling and packaging
- ▶ Pens

## Ambient conditions

### General conditions:

#### Operating temperature

- ▶ + 0 ... + 50 °C (application-based)

#### Humidity

- ▶ 10 ... 95%

#### Noise level

- ▶ 70 dB

## Materials used, media resistance

The Rexroth ActiveMover transfer system is manufactured with high-quality materials for continuous use. It is resistant to common industrial lubricants and conditioners, as well as water, mineral oil, grease and detergents.

However, we cannot guarantee that the products contained in this catalog are resistant to all combinations of testing fluids, gases or solvents. Contact us if you have any doubts about resistance to specific chemicals, such as test oil, doped oils, aggressive cleaning agents, solvents or brake fluid.

Please contact your Rexroth representative if you have any doubts.

## Use in clean rooms

A typical ActiveMover layout has been certified accordingly for use in clean rooms by Fraunhofer IPA\* in accordance with DIN EN ISO 14644-1.



\* Fraunhofer Institute for Manufacturing Engineering and Automation

# ActiveMover – configuration and commissioning

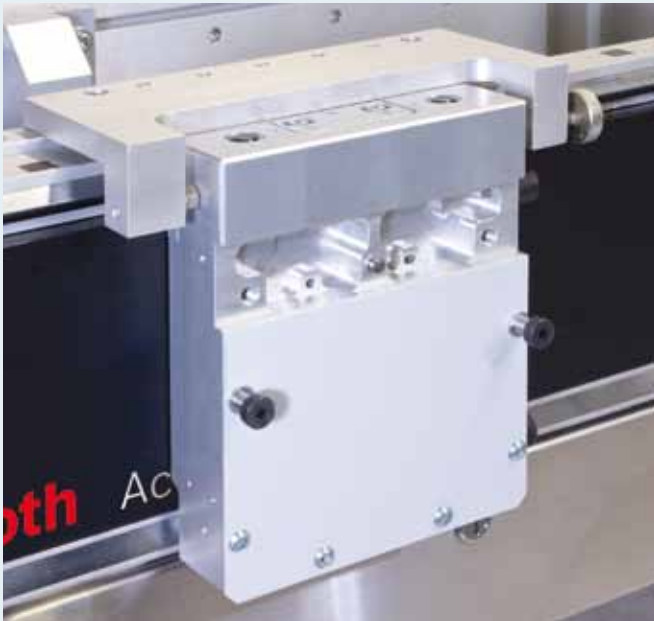

## Technical constraints

### Workpiece pallet

- ▶ Load (carrying plate + product)
  - 3 magnets:  $\leq 10$  kg
  - 2 magnets:  $\leq 2$  kg
- ▶ Sizes up to 500 mm x 300 mm  
A test should be conducted for greater widths.
- ▶ Min. distance between workpiece pallets (center-center)
  - 2 magnets:  $\geq 167$  mm
  - 3 magnets:  $\geq 200$  mm



## What you provide

- ▶ The product carrying plate is designed by you to meet the product's requirements and mounted in the designated recess in the workpiece pallet.

When fastening the load, process forces should also be taken into account.

The workpiece pallet may need to be supported.

Ideally, the product's center of gravity should be in the center and as close to the motor as possible.

- ▶ Depending on cycle time, the number of workpiece pallets should be as low as possible.





### Planning with *MTpro*

*MTpro* is an intuitive software program for planning assembly systems that assists you from selecting to configuring, to ordering Rexroth products. Components can be selected from the range via drag-and-drop and assembled quickly and easily using the snap function. Thanks to automatic parts list costing and electronic order integration, you can keep costs under control and minimize time spent ordering. Numerous interfaces allow planning data to be used by other departments, such as Design, Purchasing and Service. With *MTpro* you can plan, cost out and document your assembly systems in just a few steps.



### Configuration and commissioning

ActiveMover is commissioned quickly and easily with the *AMpro* configuration software, which monitors and calibrates the hardware. The *AMpro* software simplifies application programming by allowing the movement profiles of each workpiece pallet to be set without requiring any programming knowledge. ActiveMover offers an open interface for many popular PLC architectures. Using ready-made function modules, you can integrate your application programming to optimize processes in the assembly line.

# Component overview

**A Workpiece pallet**  
Precisely transports and positions your workpiece.

**B Section module**  
Generates electromagnetic force to drive the workpiece pallets.

**C Curve module**  
Generates electromagnetic force to drive the workpiece pallets.

**D Base frame**  
Supports the section and curve modules. Offers mounting options for control cabinets and power supplies. Adjustable feet for rough system leveling.

**E Power supply**  
Supplies power to the 28 V DC system.

**F Control cabinet**  
For electrical installation and system control.



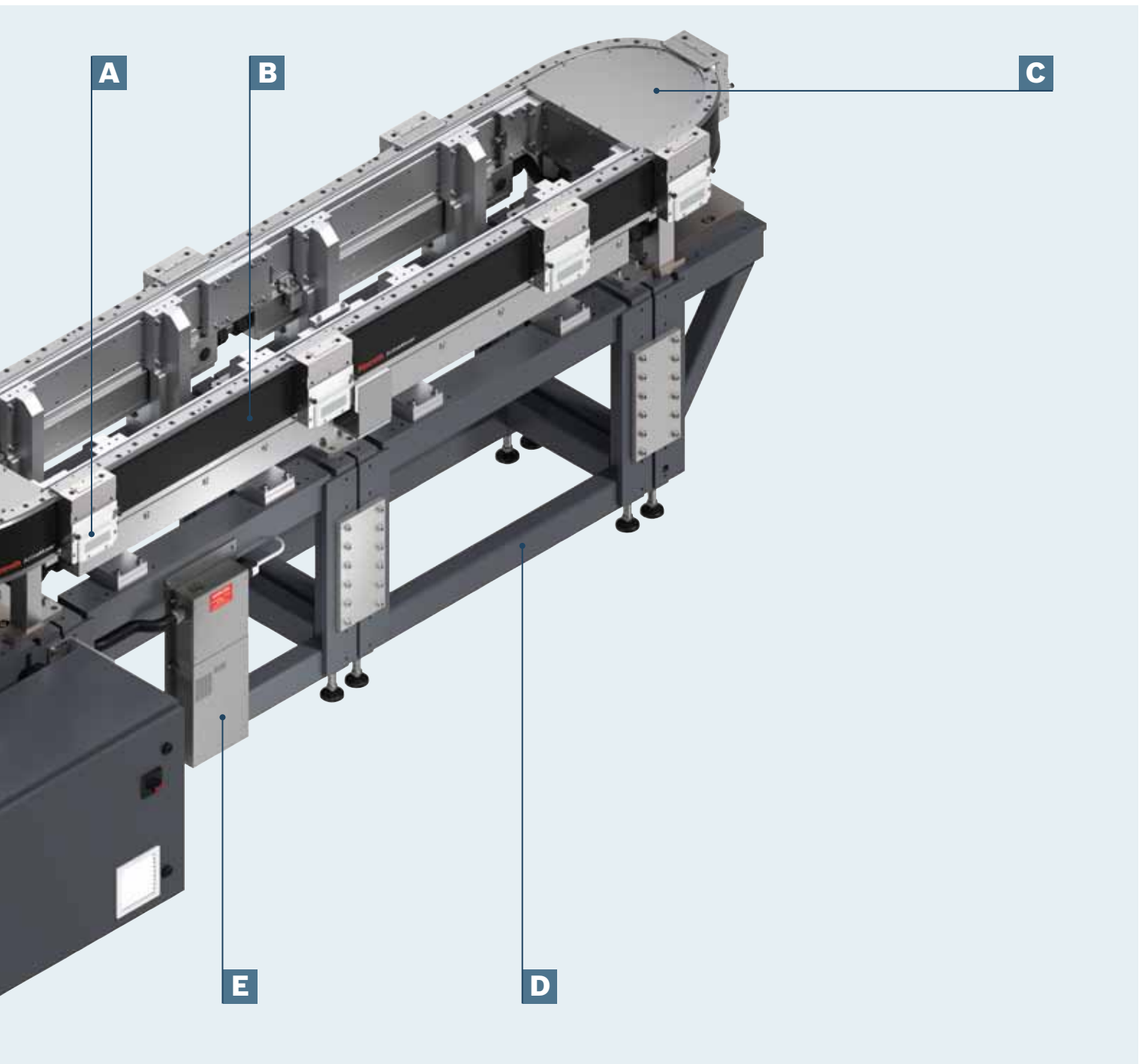

# ActiveMover – component overview

## A Workpiece pallet

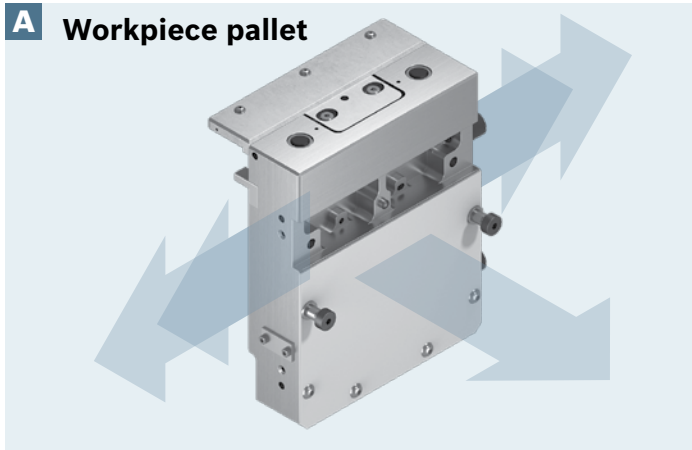

- ▶ Workpiece pallet width (incl. rubber buffer) 165 mm
- ▶ Fixture width up to 500 mm
- ▶ Two or three magnetic plates
- ▶ Loads up to 10 kg
- ▶ Bores for installing your carrying plate
- ▶ Low-maintenance
- ▶ Identification systems supported
- ▶ Individually controllable
- ▶ Open accessibility

## B Section module



- ▶ Length 1000 mm
- ▶ Integrated measuring system to detect workpiece pallet position
- ▶ Sturdy design
- ▶ Enclosed electronics box

## C Curve module

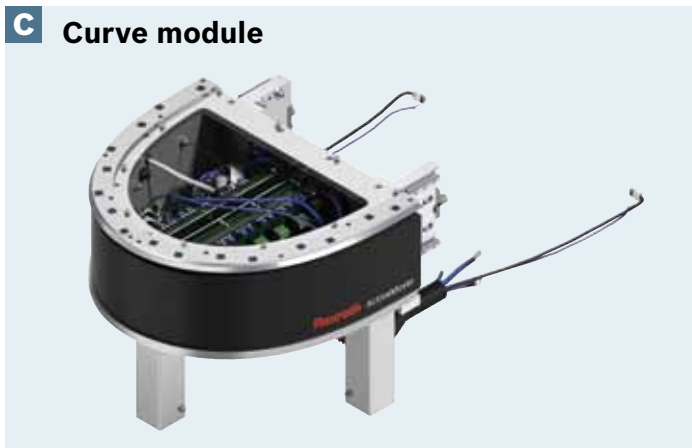

- ▶ Integrated measuring system to detect workpiece pallet position
- ▶ Sturdy design
- ▶ Electronics protected by removable cover



**D Base frame**

- ▶ Sturdy base frame in painted steel
- ▶ Standard frame length 1000 mm or compact variant length 400 mm
- ▶ Conveyor height 1100 mm
- ▶ Bores for integrating work stations/enclosures

**E Power supply set**

- ▶ Simple connection to control cabinet and modules
- ▶ Number depends on application
- ▶ Can be assembled horizontally and vertically

**F Control cabinet**

- ▶ Two versions (EU and NA)
- ▶ No assembly required for rapid commissioning
- ▶ Interface modules supported (PROFINET, Ethernet/IP, EtherCAT, etc.)
- ▶ Stop Category 1 emergency stop safety circuit per DIN EN 60204-1 supported
- ▶ Uninterruptible power supply (UPS)





# Workpiece pallet

2

---

**Workpiece pallet**

**2-6**

---

**Identification system**

**2-9**

# ActiveMover – workpiece pallet

## Precise, fast, customizable

The workpiece pallet assists in low-friction transport and precise product positioning. It also supports your carrying plate.



### Benefits of its special features:

- ▶ **Low-maintenance:** Lubricating felt easily lubricates the guide rails for longer guide roller service life and reduced wear
- ▶ **Static-free:** Any static charges are dissipated by integrated discharge brushes
- ▶ **Low-noise:** Quiet, low-vibration transitions thanks to a continuous line of contact between plastic guide rollers
- ▶ **Versatile:** Open accessibility from five sides for distinct, custom processes
- ▶ **Uncomplicated:** Your carrying plate is installed easily and reliably with bore and dowel pin
- ▶ **Stable:** Positioning prevents the workpiece pallet from tipping and protects the measuring system against any mechanical collisions with work stations
- ▶ **Safe:** Magnetic field is shielded to safely preserve the workpiece pallet

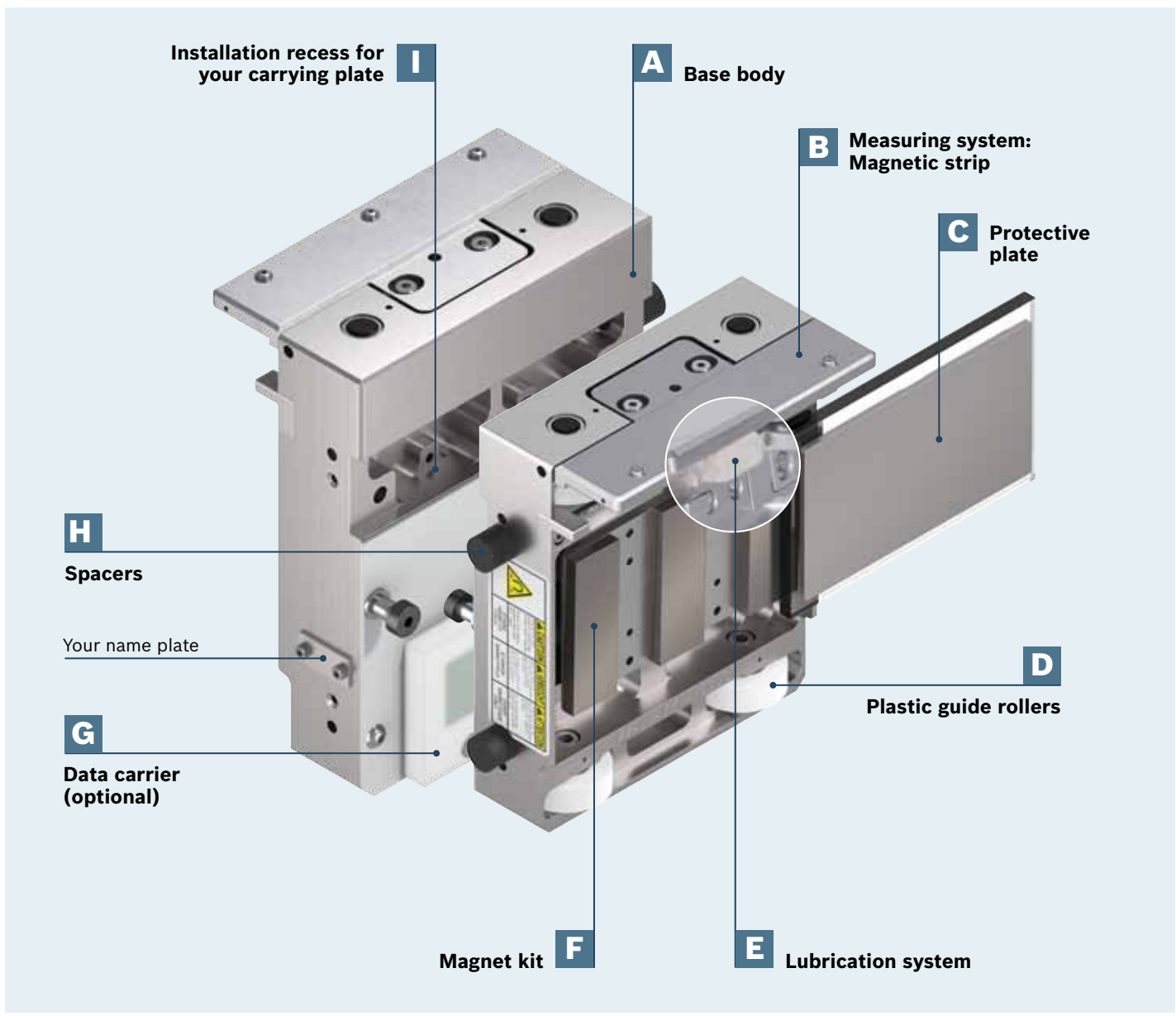



- ▶ Base body: Design with cavity to reduce weight and increase supported load
- ▶ Protective plate to shield magnetic field

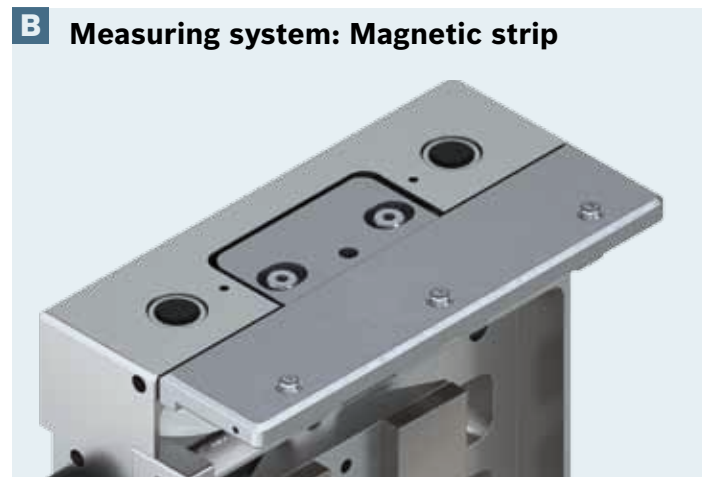

- ▶ Precise, contactless workpiece pallet position detection at full speed and acceleration



- ▶ Low-wear, quiet and low-vibration plastic guide rollers
- ▶ Provide stability and assist in precise positioning on the X-, Y- and Z-axes



- ▶ Felt acts as a lubricant reservoir
- ▶ Even film of lubricant on the guide rail reduces wear in the plastic guide rollers

**F Magnet kit**

- ▶ 2 magnets: ≤ 2 kg load
- ▶ 3 magnets: ≤ 10 kg load
- ▶ Draw the guide rollers to the guide rail
- ▶ Workpiece pallet does not need to be locked in

**G Data carrier (optional)**

- ▶ One-time, unique identification of the workpiece pallet via infrared
- ▶ Mounted directly on the workpiece pallet cover

**H Spacers**

- ▶ Can be mounted on both sides as desired (standard 13 mm)
- ▶ Provide safety during manual movement

**I Installation recess for your carrying plate**

- ▶ Recesses, threads and dowel pin to precisely attach the carrying plate and prevent rotating

## Workpiece pallet



- ▶ Available in two versions:
  - 2 magnet plates ( $\leq 2$  kg load)
  - 3 magnet plates ( $\leq 10$  kg load)
- ▶ Protective plate to shield magnetic field
- ▶ Low-wear, quiet and low-vibration plastic guide rollers
- ▶ Low-maintenance and long-lasting thanks to lubricating felt to evenly lubricate guide rails/rollers
- ▶ Variable load centers of gravity thanks to guide rollers
- ▶ Open accessibility to workpiece pallets from five sides
- ▶ Identification systems supported

The workpiece pallet ensures low-friction transport and precise product positioning. Bores and recesses allow your carrying plate (up to 500 mm) to be attached.

The workpiece pallet can support a data carrier (infrared). The data on the data carrier can be read at full speed and acceleration as the workpiece pallet passes through the reading station.

### Accessories

#### Recommended accessories

- ▶ Data carrier
- ▶ Felt lubrication: ISO VG 46 food-grade lubricant

### Delivery information

#### Included in delivery

- ▶ Protective plate to shield magnetic field when workpiece pallet is removed

#### Condition on delivery

- ▶ No assembly required

### Ordering information

Product designation	Material number
Workpiece pallet with 2 magnets	3 842 559 433
Workpiece pallet with 3 magnets	3 842 559 434



**Technical data**

<b>Material number</b>		<b>3 842 559 433</b>	<b>3 842 559 434</b>
<b>Properties</b>			
Workpiece pallet weight	kg	2.18	2.65
Load	kg	≤ 2	≤ 10
Material		Cover: thermoplastic film Lubricating felt: SAE F-1 Magnets: neodymium Guide roller: POM Rubber buffer: chloroprene rubber (CR) Protective plate: polycarbonate (PC) + steel Base plate: anodized aluminum	Cover: thermoplastic film Lubricating felt: SAE F-1 Magnets: neodymium Guide roller: POM Rubber buffer: chloroprene rubber (CR) Protective plate: polycarbonate (PC) + steel Base plate: anodized aluminum
<b>Additional information</b>			
Magnetic field strength	Gs	2.5 ... 268.0	3.0 ... 1400.0
Max. acceleration*	Section module, 1 kg load	m/s <sup>2</sup> 40	40
	Section module, 10 kg load	m/s <sup>2</sup> –	10
	Curve module, 1 kg load	m/s <sup>2</sup> 20	20
Max. speed*	Section module	m/min 150	150
	Curve module	m/min 150 (load-based)	150 (load-based)
Max. acceleration force (motor)	N	120	160
Magnetic force	Section module	N 860	1290
	Curve module	N 430	645
Max. input power	W	275	275
Positioning accuracy*	Curve module	mm –	–
	Section module	mm 0.050 (X-axis)	0.050 (X-axis)
Repeat accuracy* of single workpiece pallet	Curve module	mm ± 0.025 (X-/Y-/Z-axis)	± 0.025 (X-/Y-/Z-axis)
	Section module	mm ± 0.01 (X-axis)	± 0.01 (X-axis)
		mm ± 0.015 (Y-axis)	± 0.015 (Y-axis)
		mm ± 0.025 (Z-axis)	± 0.025 (Z-axis)

\* Orientation information, values depend on application.

**Min. distance between workpiece pallets**

The min. distance between workpiece pallets depends on the workpiece pallet version and is measured from the center of one workpiece pallet to the center of another workpiece pallet.

		<b>3 842 559 433</b>	<b>3 842 559 434</b>
Curve module	mm	200	200
Section module	mm	167 (with rubber buffer)	200
		154 (without rubber buffer)	

**Dimensions**

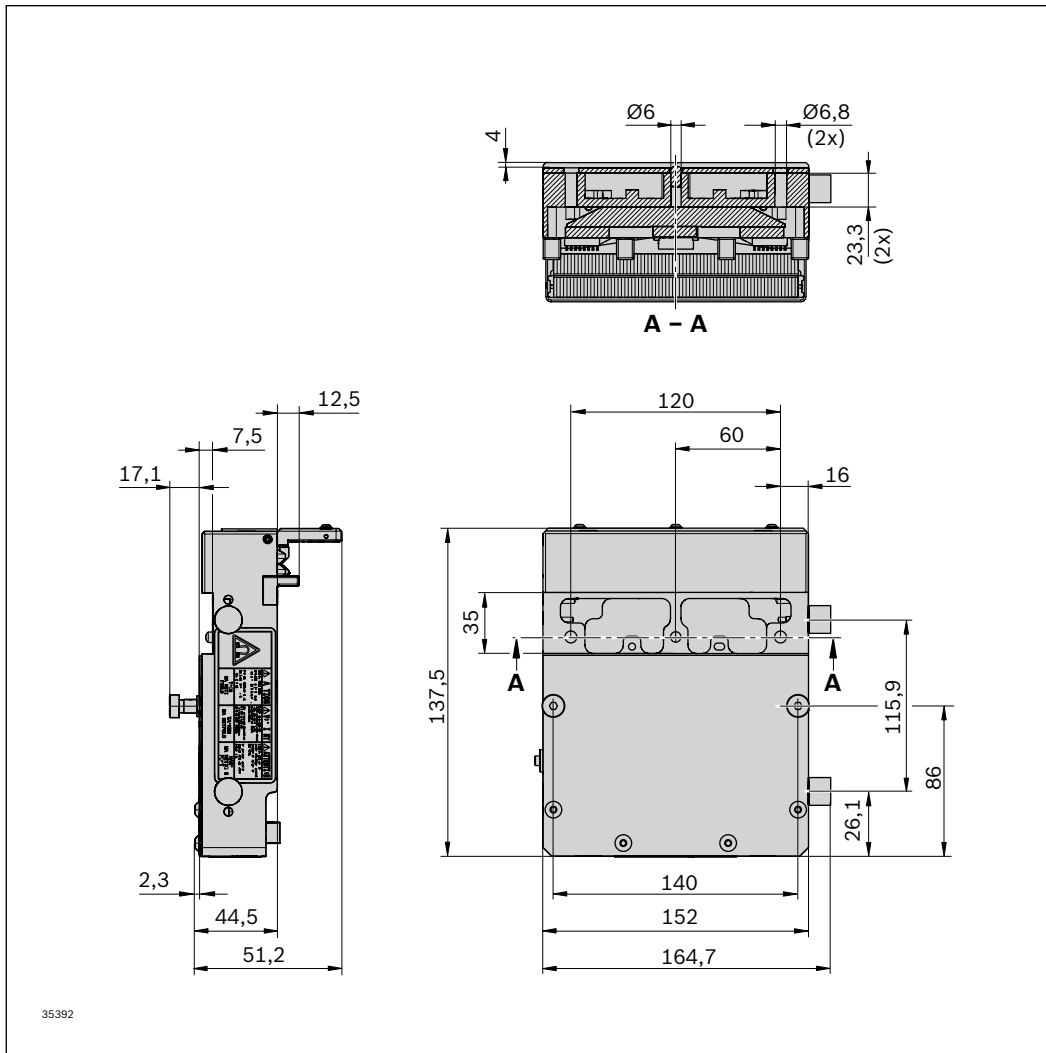

# Identification system

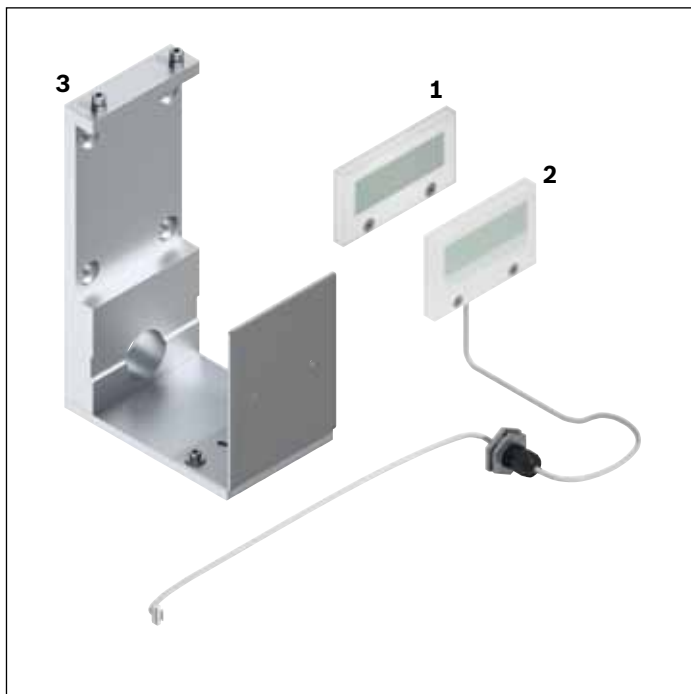

- ▶ Data carrier (1) for uniquely identifying the workpiece pallet (data integrity)
- ▶ Reading head (2) for reading the data at full speed and acceleration
- ▶ Assembly kit (3) for mounting the reading head and adjusting the distance between reading head and data carrier
- ▶ Infrared data transmission
- ▶ Configuration via AMpro software

The workpiece pallet is uniquely identified by a data carrier mounted to the workpiece pallet. The reading head is plug-and-play and is attached to the section module, reading the data carrier number as soon as the workpiece pallet passes through the reading station.

The required distance between reading head and data carrier is 1 mm.

To be able to identify the number saved on the data carrier, the data carrier's number is physically engraved on its side (see Fig. on p. 2-11).

## Accessories

### Required accessories

- ▶ AMpro software

### Delivery information

#### Included in delivery

- ▶ Depending on order:
  - Data carrier, incl. fastening material
  - Reading head, incl. connecting cable and fastening material
  - Assembly kit

#### Condition on delivery

- ▶ Assembly required

## Ordering information

Product designation	L (mm)	Material number
Data carrier		3 842 559 447
Reading head	1500	3 842 559 441
Assembly kit		3 842 559 440

**Technical data**

<b>Material number</b>		<b>3 842 559 447</b>	<b>3 842 559 441</b>	<b>3 842 559 440</b>
<b>Properties</b>				
Weight	kg	0.1	0.3	2.4
Material		POM	POM, nickel-plated brass, PVC	Anodized aluminum, Steel
<b>Additional information</b>				
Reading distance <sup>1)</sup>	mm	–	1	–
Reading speed	m/min	–	≤ 150	–
Acceleration	m/s <sup>2</sup>	–	≤ 40	–
Laser		–	Class 1	–

<sup>1)</sup> Distance between reading head and data carrier

**Dimensions**

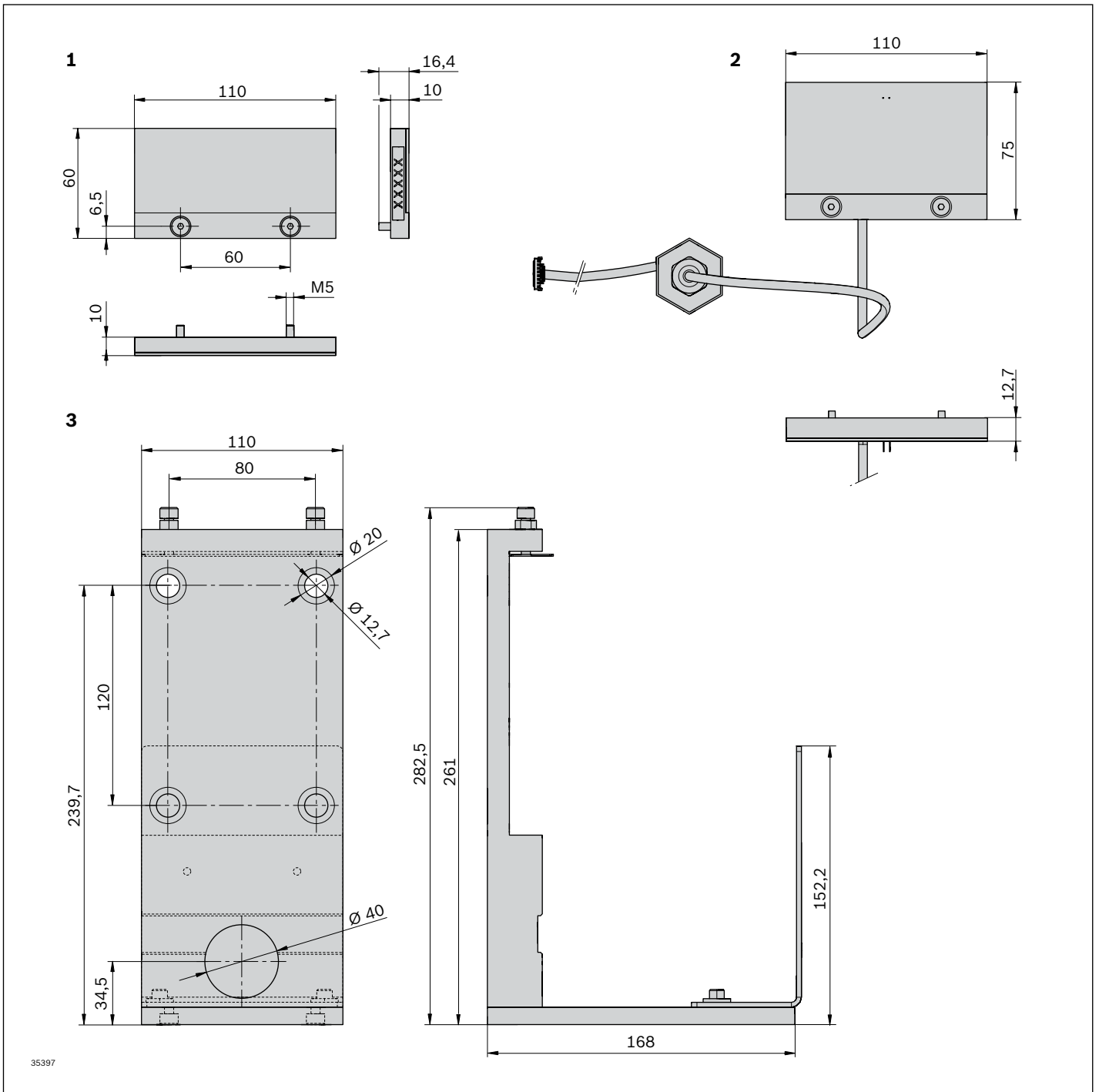

35397

- 1** Data carrier, XXXXX = data carrier identification number
- 2** Reading head
- 3** Assembly kit





# Sections

3

<b>Section module</b>	<b>3-6</b>
<b>Module holder</b>	<b>3-8</b>
<b>Section module connecting kit</b>	<b>3-10</b>
<b>Curve module</b>	<b>3-12</b>

# ActiveMover – modules

## Uncomplicated, sturdy, accurate

Sturdy section and curve modules support the low-friction movement of the workpiece pallet and ensure an ultra-precise production process.



### Benefits of its special features:

- ▶ **Low-maintenance:** Save on spare parts through innovative technology and modular components
- ▶ **Sensitive:** Special guide rails ensure a gentle production process and simplify workpiece pallet conversion
- ▶ **Uncomplicated:** Simple adjusting with a special connecting kit and compatible with fastening elements from Rexroth's Basic Mechanical Elements line
- ▶ **Stable:** Vertical and horizontal workpiece pallet support function
- ▶ **Safe:** Electronic components installed in an electronics box with flap guard
- ▶ **Ultra-precise:** Precise, contactless position detection via measuring system and ultra-precise workpiece pallet positioning guaranteed



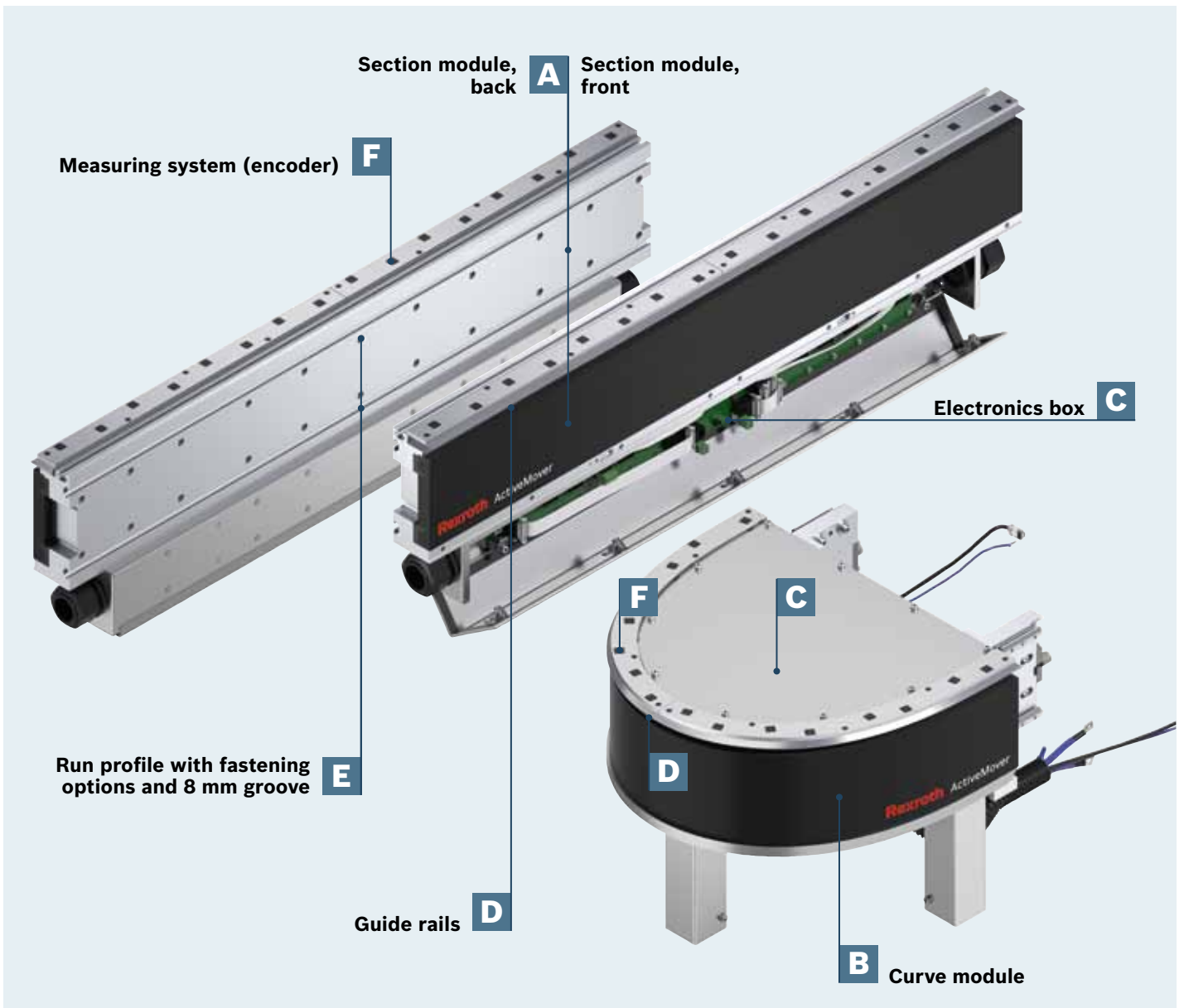

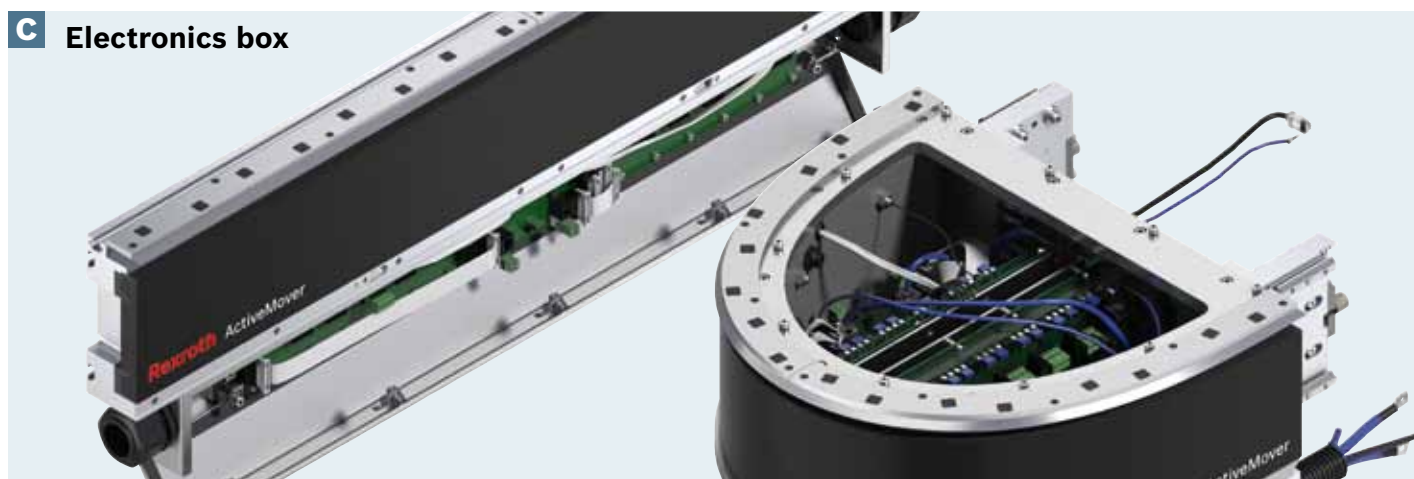
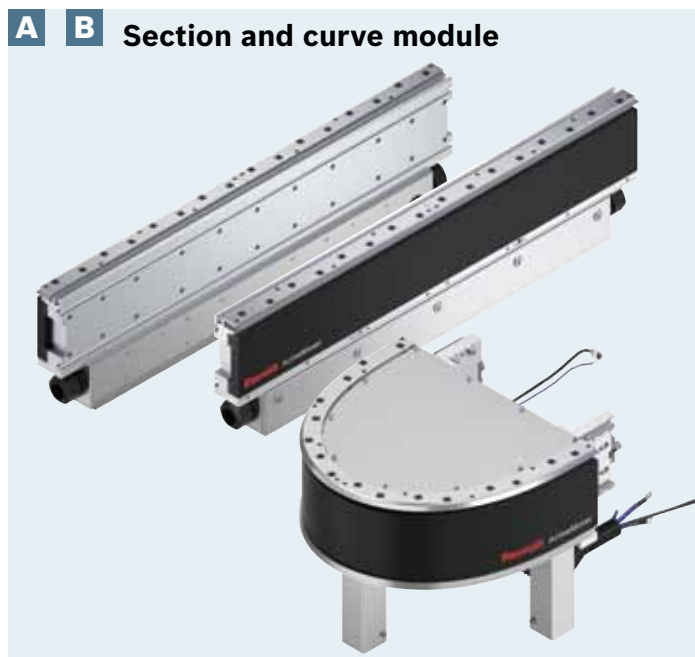

**A B** Section and curve module

**Section and curve module**

- ▶ For generating an electromagnetic field for workpiece pallet transport
- ▶ Modular design, fewer spare parts and reduced installation errors
- ▶ Curve profile prevents jerky movements (shocks/jerks/vibration) in the workpiece pallet to protect the product. Workpiece pallet can be positioned exactly where desired even on the curve module
- ▶ Straight section at the ends of the curve module ensure:
  - Gentle workpiece pallet transition
  - Easy and minor adjusting of curves
  - Easy and minor adjusting of guide rails, reducing wear, vibrations and noise

**C** Electronics box

**Section module**

- ▶ Flap guard for quick accessibility and maintenance
- ▶ Connecting cables can be inserted from the side
- ▶ Cable socket with EMC protection (electromagnetic compatibility)

**Curve module**

- ▶ Electronics protected by removable cover
- ▶ Connecting cables can be inserted from below



**D Guide rail**

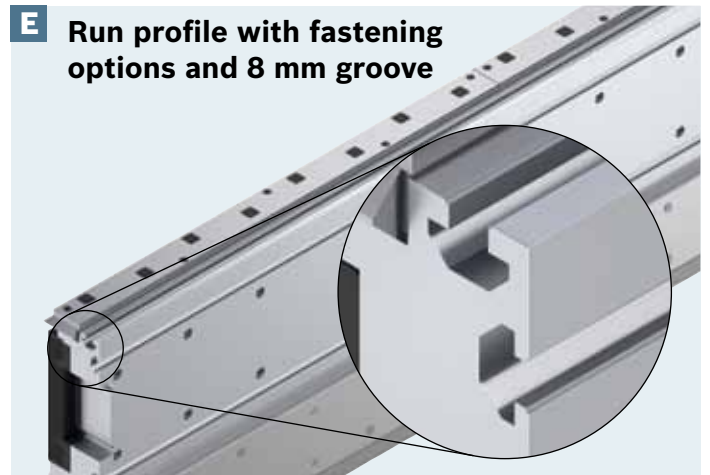

**E Run profile with fastening options and 8 mm groove**

**Section and curve module**

- ▶ For vertical and horizontal workpiece pallet support
- ▶ Allows for easy workpiece pallet conversion
- ▶ With overlapping transitions to compensate for tolerances and minimize gaps

**Section module**

- ▶ For mounting brackets, cable ducts, etc.
- ▶ Compatible with fastening elements from Rexroth's Basic Mechanical Elements line

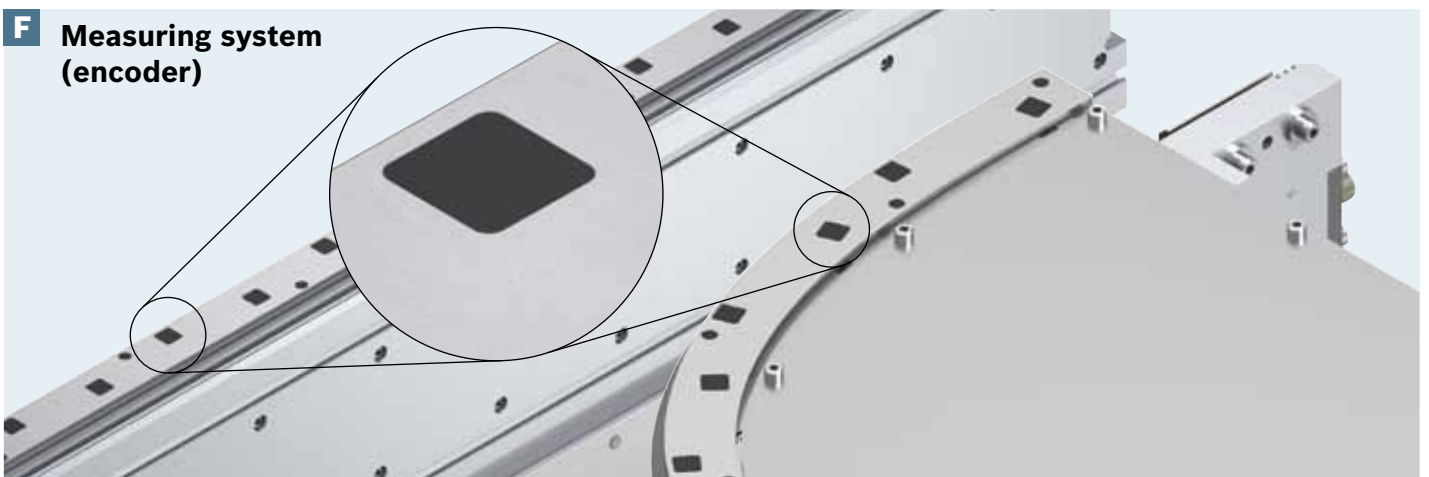

**F Measuring system (encoder)**

**Section and curve module**

- ▶ Precise, contactless position detection at full speed and acceleration
- ▶ Valid position values supplied at any position
- ▶ Mounted to aluminum profiles for quick and easy replacing
- ▶ Protective cap protects against soiling and foreign bodies
- ▶ 1 µm travel resolution
- ▶ Same measuring system for section and curve modules

## Section module



- ▶ For generating and regulating an electromagnetic field for workpiece pallet transport
- ▶ Integrated measuring system (encoder) to for contactless workpiece pallet position detection
- ▶ Enclosed electronics box
- ▶ For quickly and easily removing workpiece pallets, as the guide rollers on the workpiece pallet are not interlocked with the system
- ▶ 8 mm groove for mounting brackets, cable ducts, etc. (compatible with fastening elements from Rexroth's Basic Mechanical Elements line)

The motor on the run profile generates and regulates the electromagnetic field for transporting the workpiece pallet. The electronics box on the section module is easily accessed by a flap guard. Installation cables can be inserted from the side, and power supply and identification system cables from below. The integrated measuring system (encoder) ensures precise detection of any workpiece pallet position.

The chamfered ends of the guide rails allow modules to overlap. This gives the guide rollers continuous contact with the guide rails, providing low-friction and low-vibration transport between section modules.

### Accessories

#### Required accessories

- ▶ Module holder, section module connecting kit

### Delivery information

#### Included in delivery

- ▶ Cable socket with EMC protection (electromagnetic compatibility)
- ▶ Centering piece
- ▶ T-slot stones for assembling section module connecting kit

#### Condition on delivery

- ▶ No assembly required

### Ordering information

Product designation	L (mm)	Material number
28 V DC section module	1000	3 842 559 426

**Technical data**

<b>Material number</b>		<b>3 842 559 426</b>	
<b>Properties</b>			
Weight		kg	41
Material			Anodized aluminum, stainless steel, PA, PC, epoxy
<b>Additional information</b>			
Voltage		V DC	28 (motor) 24 (digital)
Max. number of section modules/system		Modules	48
Max. acceleration force	Workpiece pallet with 2 magnets	N	120
	Workpiece pallet with 3 magnets	N	160
Max. input power		W	10

**Dimensions**

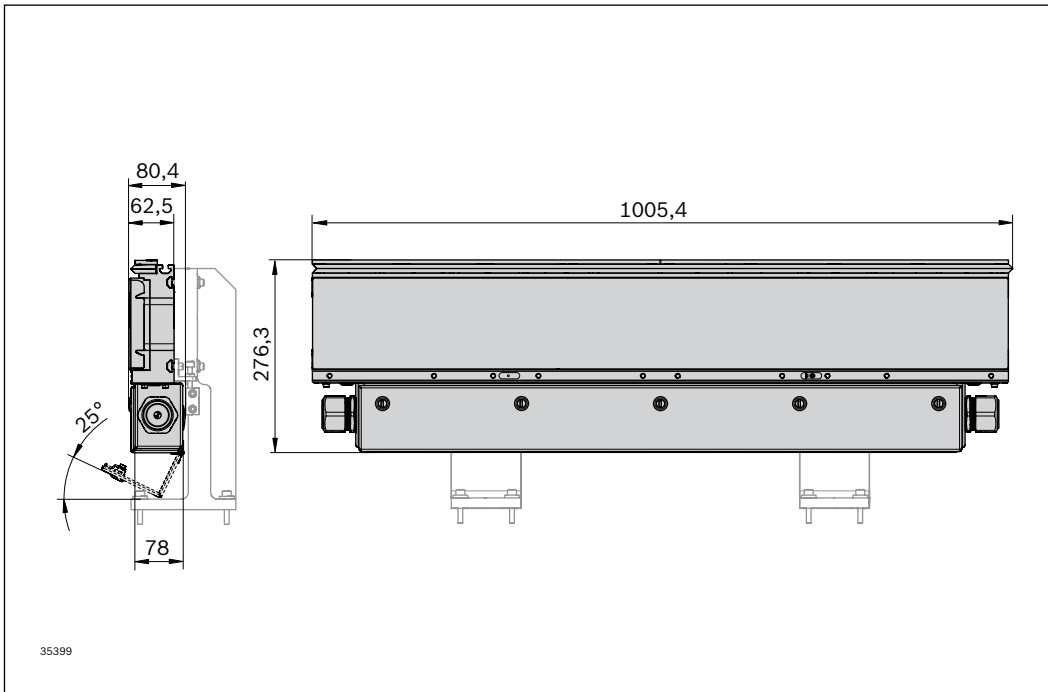

## Module holder



- ▶ For easy, stable mounting of the section module to the base frame
- ▶ Allows the section module height to be adjusted easily
- ▶ With bores and threads to allow you to install covers

Module holder for mounting the section module on the base frame. Module holders can be height-adjusted to compensate for the height offset between section modules.

### Accessories

#### Required accessories

- ▶ Fixing plate

### Delivery information

#### Included in delivery

- ▶ Fastening material and height adjuster

#### Condition on delivery

- ▶ Assembly required

### Ordering information

Product designation	Packaging unit	Material number
Module holder	Set	3 842 559 429

### Technical data

<b>Material number</b>		<b>3 842 559 429</b>
<b>Properties</b>		
Weight	kg	8
Material		Anodized aluminum

**Dimensions**

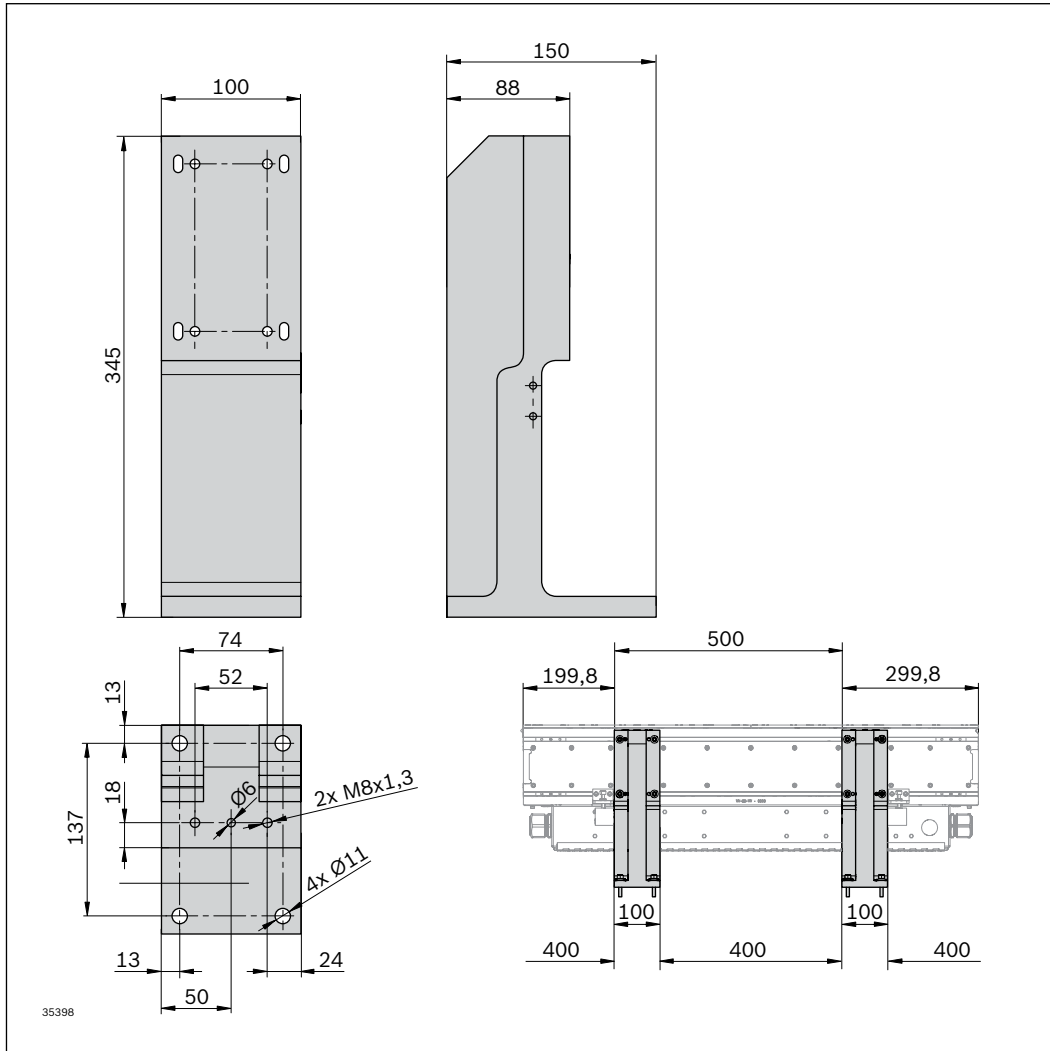

**Notice:** Recommended holder spacing: 400 mm

## Section module connecting kit

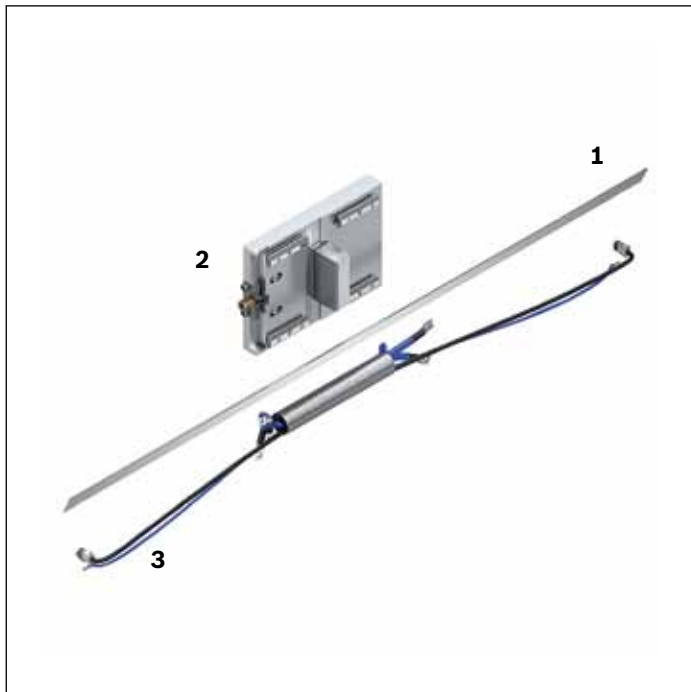

- ▶ For connecting section modules
- ▶ For making fine adjustments and compensating for tolerances between section modules

Connecting kit for making precise lateral adjustments ( $\pm 20 \mu\text{m}$ ) to section modules. The flat guide rail is mounted to the section modules using small magnets. The chamfered ends of the guide rails allow modules to overlap.

This gives the guide rollers continuous contact with the guide rails, providing low-friction and low-vibration transport between section modules. Sensitive products can be transported without damage.

### Delivery information

#### Included in delivery

- ▶ Fastening material
- ▶ Flat guide rail (1) L = 1000 mm
- ▶ Connecting plate (2) (incl. connecting block, adjusting screw, adjusting wedge)
- ▶ Cable set (3), incl. installation material for section modules, consisting of 3x cable (0 V, 24 V, 28 V DC), grounding cable, network cable and cable guard pipe

#### Condition on delivery

- ▶ Assembly required

### Ordering information

Product designation	Packaging unit	Material number
Section module connecting kit	Set	3 842 559 438



**Technical data**

<b>Material number</b>		<b>3 842 559 438</b>
<b>Properties</b>		
Weight	kg	3.3
Material		Anodized aluminum
<b>Dimensions</b>		
Guide rail length	mm	1000

## Curve module



- ▶ For generating and regulating an electromagnetic field for workpiece pallet transport
- ▶ Integrated measuring system (encoder) to for contactless workpiece pallet position detection
- ▶ Electronics protected by removable cover
- ▶ For quickly and easily removing workpiece pallets, as the guide rollers on the workpiece pallet are not interlocked with the system
- ▶ Sturdy bracket

The motor on the curve module generates and regulates the electromagnetic field for transporting the workpiece pallet. The electronics are easily accessed via a cover. Installation cables can be inserted from below. The integrated measuring system (encoder) ensures precise detection of any workpiece pallet position. Module holders with

adjusting screws to precisely align and mount the curve module to the base frame. The chamfered ends of the guide rails allow modules to overlap.

This gives the guide rollers continuous contact with the guide rails, providing low-friction and low-vibration transport between curve modules/modules.

### Accessories

#### Required accessories

- ▶ Incl. fixing plate for mounting to base frame

### Delivery information

#### Included in delivery

- ▶ Fastening material
- ▶ Curve module connecting kit (incl. guide rail)  
L = 500 mm; adjusting wedge; connecting block; cable set, incl. installation material for section modules, consisting of 3x cable (0 V, 24 V, 28 V DC), grounding cable, network cable and cable guard pipe
- ▶ Module holder, incl. cover

#### Condition on delivery

- ▶ Some assembly required

### Ordering information

Product designation	Material number
Curve module	3 842 559 430

### Technical data

Material number	3 842 559 430	
-----------------	---------------	--

#### Properties

Weight	kg	65
Material		Anodized aluminum, stainless steel, PA, PC, epoxy

#### Additional information

Voltage	V DC	28 (motor) 24 (digital)
Max. input power	W	10

### Dimensions

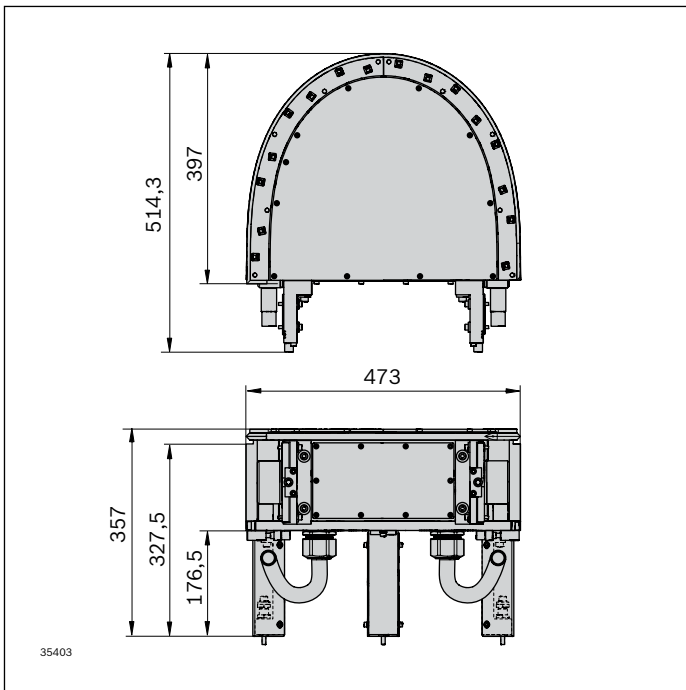





# Base frame

4

---

<b>Base frame</b>	<b>4-6</b>
-------------------	------------

---

<b>Fixing plate</b>	<b>4-8</b>
---------------------	------------

---

<b>Base frame connecting kit</b>	<b>4-10</b>
----------------------------------	-------------

# ActiveMover – base frame

## Sturdy base, compact and flexible

The sturdy design of the base frames offers a flexible base for tailored solutions. Perfectly tuned to all ActiveMover components.



### Benefits of its special features:

- ▶ **Safe:** Sturdy design in painted steel offers a safe base for all components and your work stations
- ▶ **Reliable:** High-quality materials and practical experience ensure perfect interaction between all required components and trouble-free management of any loads encountered
- ▶ **Customizable:** Bores allow for any level of expansion for tailored solutions

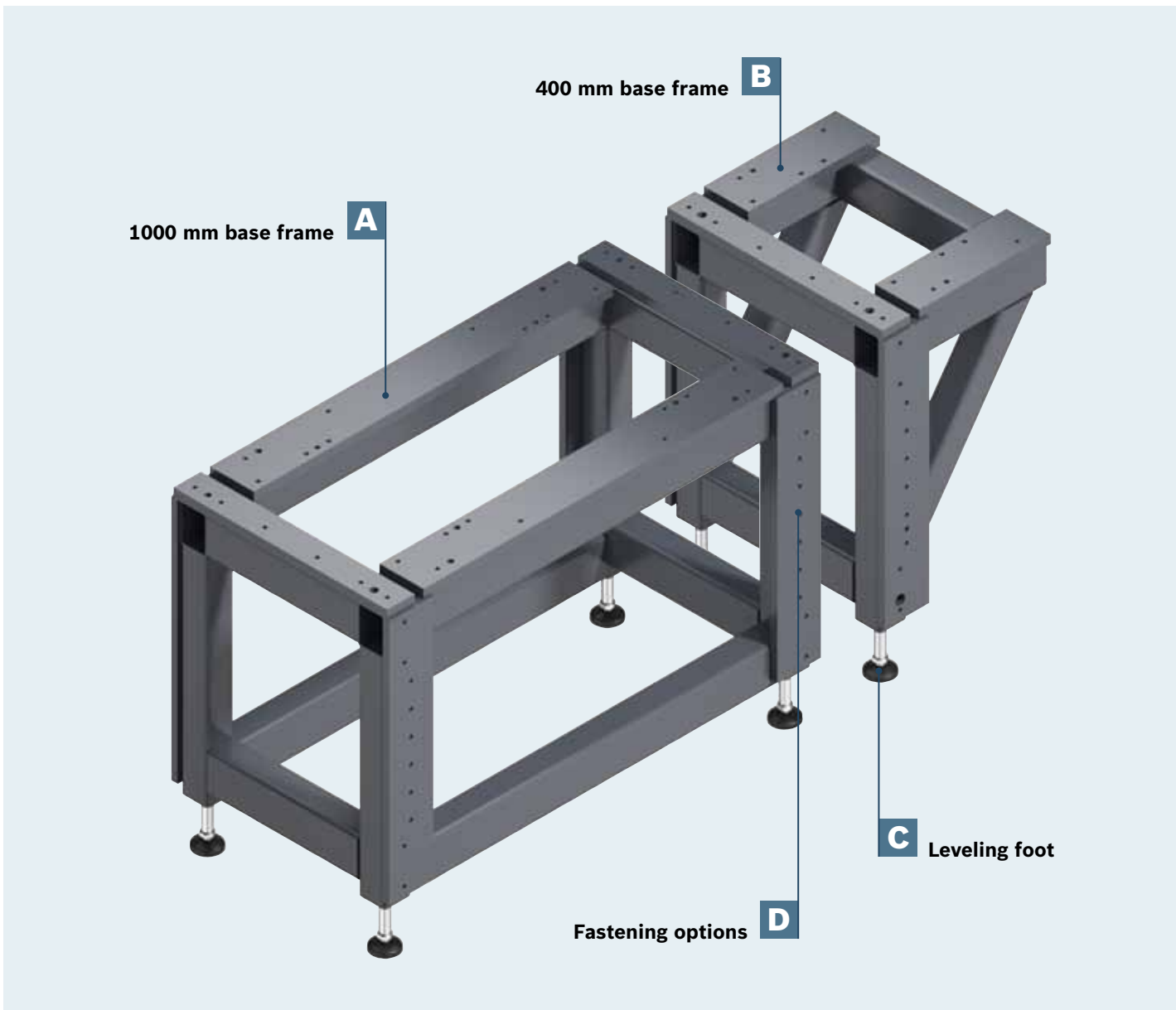

**A** 1000 mm base frame



- ▶ Sturdy base frame in painted steel
- ▶ Standard frame for the section and curve modules, 1000 mm long
- ▶ Conveyor height 1100 mm
- ▶ Supports ActiveMover control cabinet

**B** 400 mm base frame



- ▶ Sturdy base frame in painted steel
- ▶ Sturdy base frame for mounting curve modules, 400 mm long
- ▶ Conveyor height 1100 mm



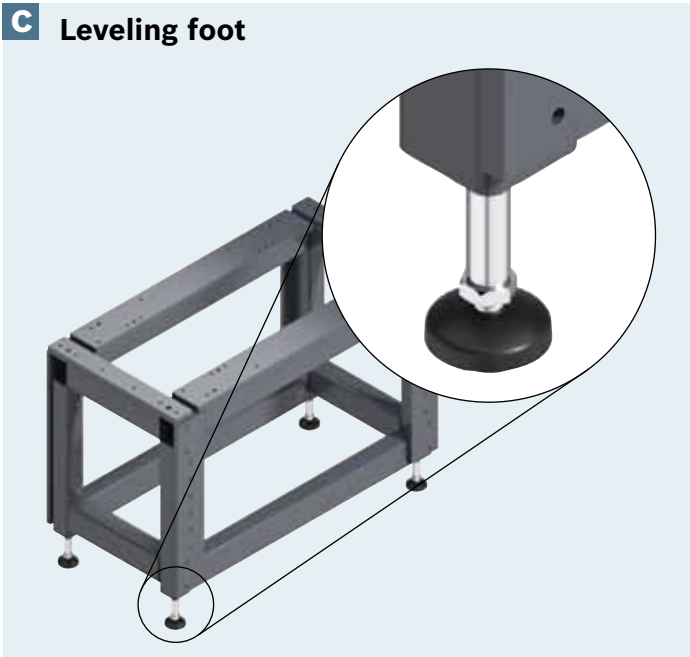

**C Leveling foot**

- ▶ Adjustable leveling feet for stability
- ▶ Support system leveling

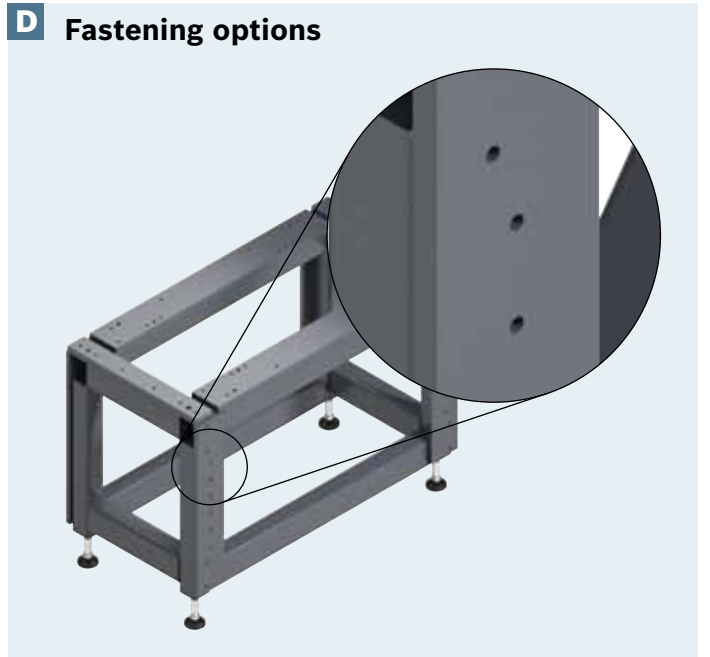
**D Fastening options**

- ▶ Comes with prefabricated threads and bores for mounting work stations and enclosures, or components such as control cabinet, fixing plates and connecting kits

- ▶ Note the fastening options for flexible power supply placement



## Base frame



- ▶ Base frame (1) up to L = 1000 mm for section or curve modules
- ▶ Base frame (2) up to L = 400 mm for curve modules
- ▶ With adjustable leveling feet
- ▶ With bores and threads for mounting fixing plates, connecting kits and control cabinets

The sturdy base frame is used to securely mount curve and section modules.

### Accessories

#### Required accessories

- ▶ L = 1000 mm: fixing plate for section and curve modules
- ▶ L = 400 mm: fixing plate for curve modules
- ▶ Base frame connecting kit

### Delivery information

#### Condition on delivery

- ▶ No assembly required

### Ordering information

Product designation	Material number
Base frame L 1000	3 842 559 450
Base frame L 400	3 842 559 451

**Technical data**

<b>Material number</b>	<b>3 842 559 450</b>	<b>3 842 559 451</b>
<b>Properties</b>		
Weight	kg	
	135	62
Material	Painted steel (RAL 7024), die-cast zinc, galvanized steel	Painted steel (RAL 7024), die-cast zinc, galvanized steel
<b>Dimensions</b>		
Length	1000	400
Conveyor height	1100	1100

4

**Dimensions**

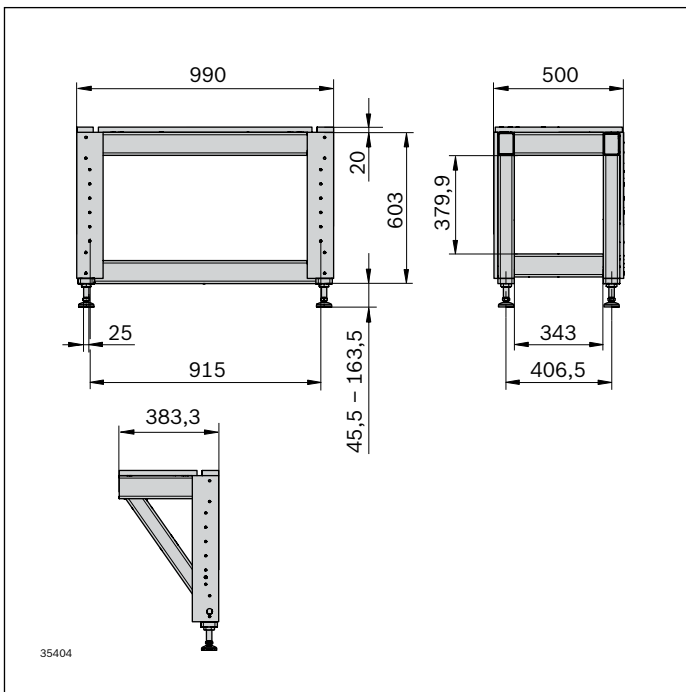

## Fixing plate

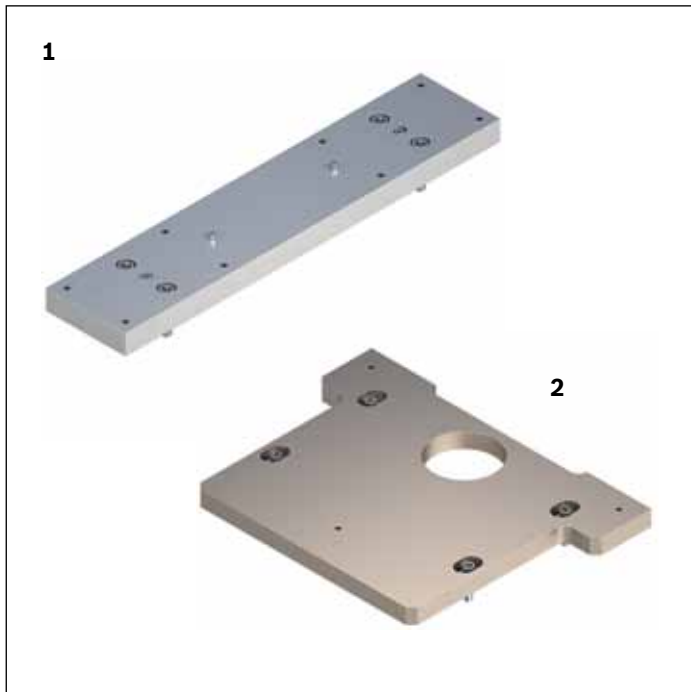

- ▶ Section module fixing plate **(1)** for mounting the section module on the base frame.
- ▶ Curve module fixing plate **(2)** for mounting the curve module on the base frame, with recess for cable passage

Fixing plates for mounting section and curve modules to the base frame.

### Delivery information

#### Included in delivery

- ▶ Fastening material

#### Condition on delivery

- ▶ Assembly required

### Ordering information

Product designation	Packaging unit	Material number
Section module fixing plate	Set	3 842 559 454
Curve module fixing plate	–	3 842 559 455

### Technical data

Material number		3 842 559 454	3 842 559 455
<b>Properties</b>			
Weight	kg	6.7	8.5
Material		Anodized aluminum	Anodized aluminum

**Dimensions**

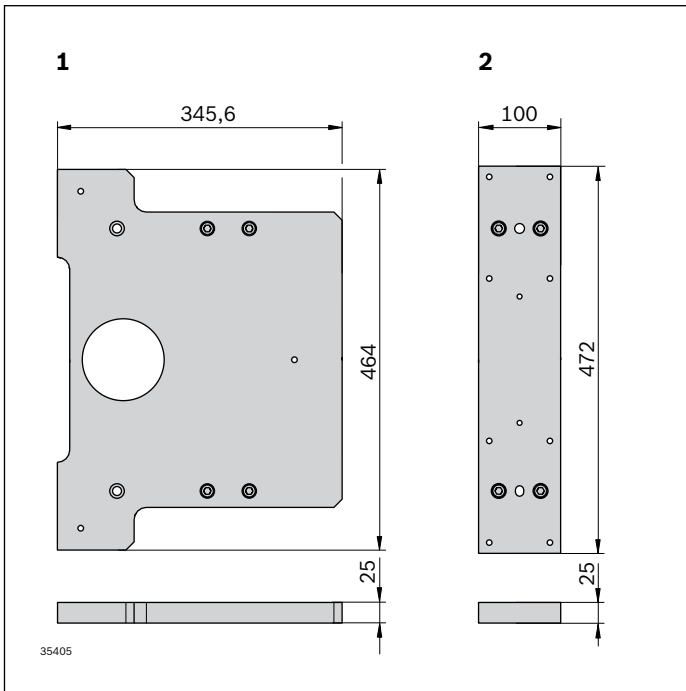

## Base frame connecting kit

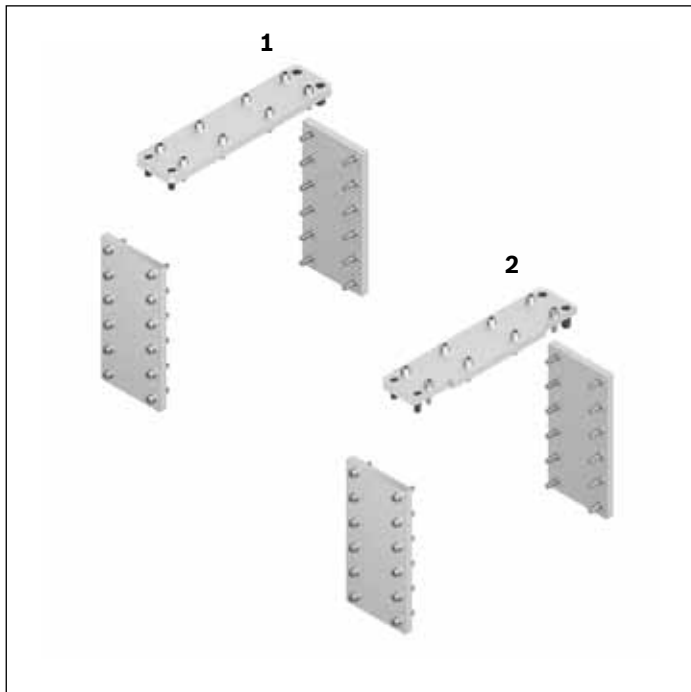

- ▶ Connecting kit **(1)** for connecting two base frames (between section modules)
- ▶ Connecting kit **(2)** for connecting two base frames (between curve module and section module)

Base frame connecting kit for connecting base frames and section or curve modules.

### Accessories

#### Recommended accessories

- ▶ Base frame

### Delivery information

#### Included in delivery

- ▶ Fastening material

### Ordering information

Product designation	Packaging unit	Material number
Base frame connecting kit (section module)	Set	3 842 559 452
Base frame connecting kit (curve module)	Set	3 842 559 453

### Technical data

Material number	3 842 559 452	3 842 559 453
<b>Properties</b>		
Weight	kg	17
Material	Nickel-plated steel	Nickel-plated steel

### Dimensions

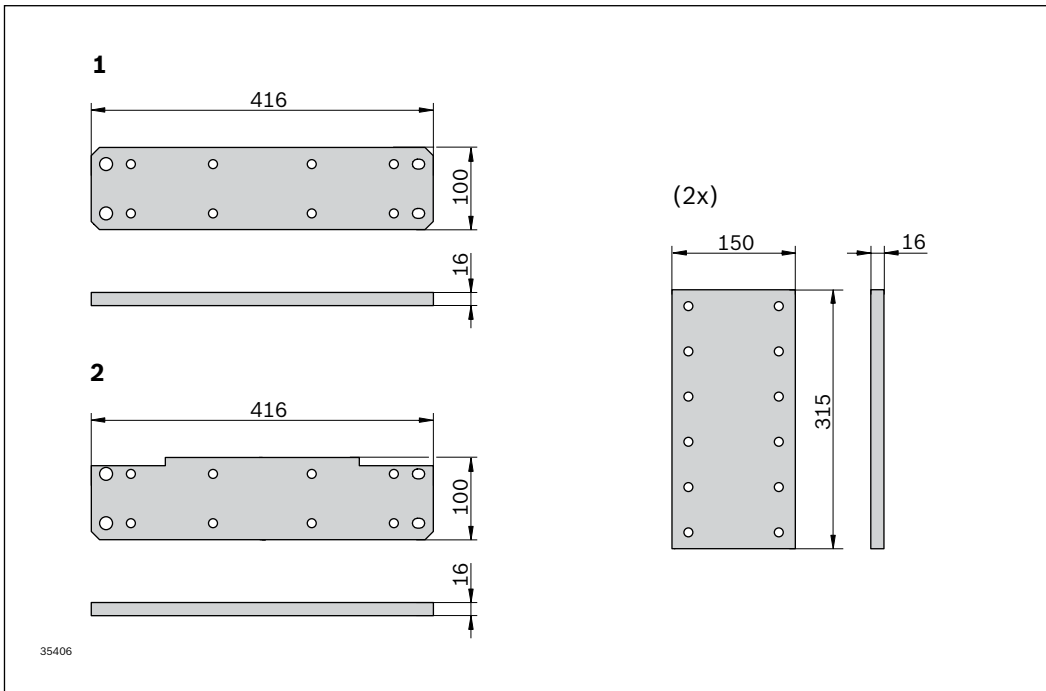







# Power supply

---

**Power supply set** **5-6**

---

**Control cabinet** **5-8**

# ActiveMover – power supply

## Reliable, powerful, efficient

Power supply and control cabinet form the perfect combination for an efficient, reliable system.



### Benefits of its special features:

- ▶ **Reliable:** Various interfaces available for tailored requirements
- ▶ **Powerful:** Rexroth quality and experience guarantee perfect interaction between all necessary components
- ▶ **Efficient:** The built-in uninterruptible power supply (UPS) ensures the system shuts down safely without losing data in the event of a power failure or voltage fluctuations

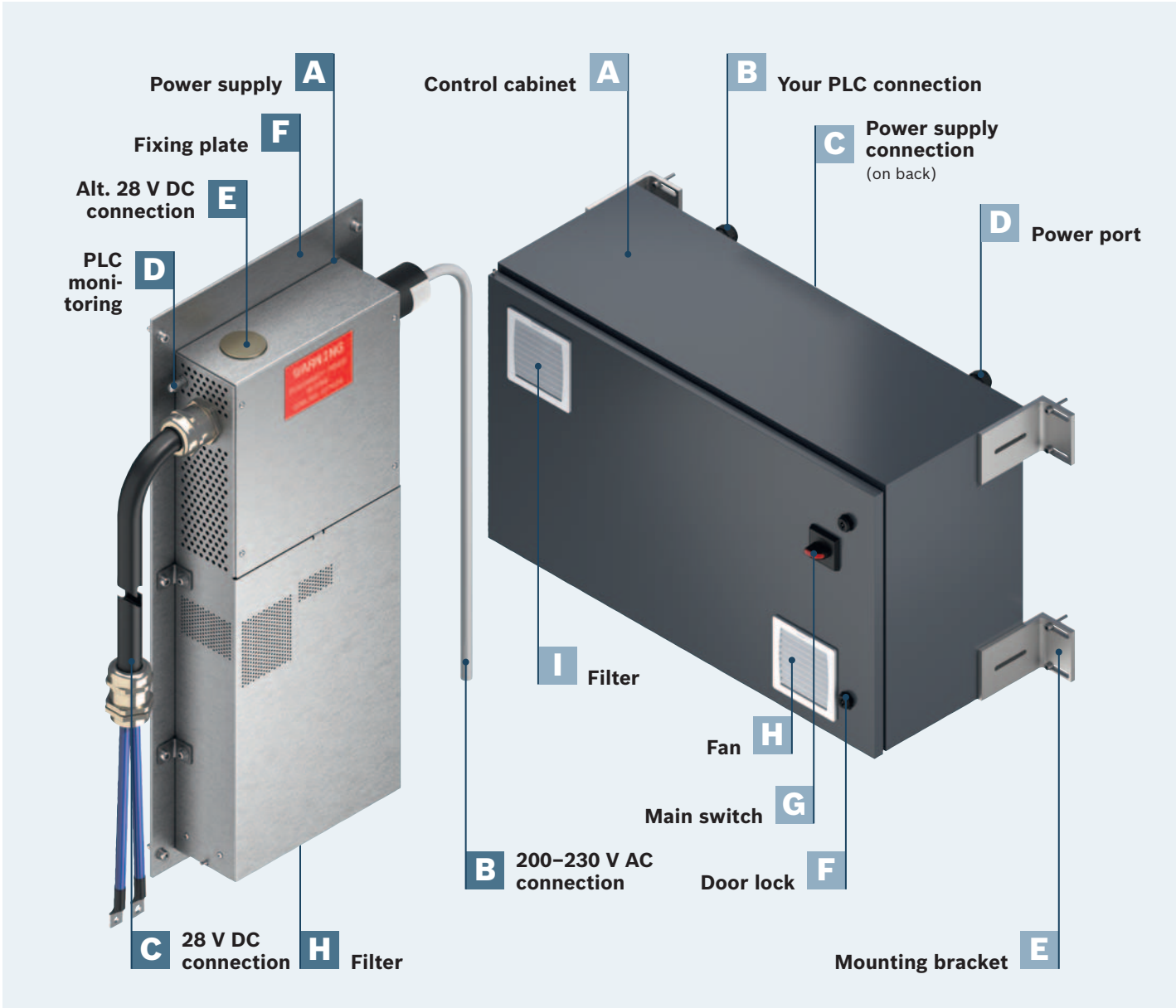

**A** Power supply

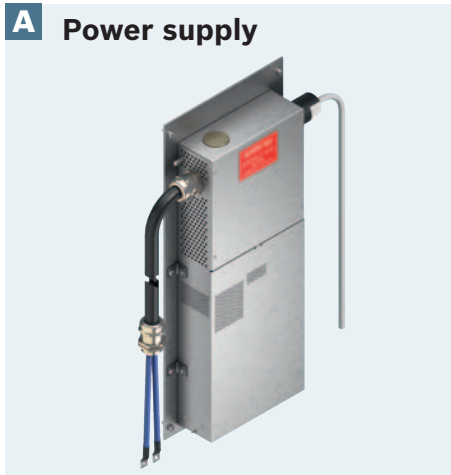

- ▶ 28 V DC system power supply
- ▶ Horizontal or vertical mounting

**B** 200–230 V AC connection



- ▶ Plug connector for your 200–230 V AC connection to control cabinet

**C E** 28 V DC connections



- ▶ Output for powering section and curve modules
- ▶ Cable length 1.5 m

**D** PLC monitoring



- ▶ PLC monitoring of power supply

**F** Fixing plate



- ▶ For mounting the power supply to a Rexroth base frame or your base frame

## A Control cabinet

- ▶ 2 versions: EU and NA
- ▶ Built-in controller, UPS and all necessary electrical components
- ▶ Interface modules (Ethernet/IP, EtherCAT, PROFINET, etc.)
- ▶ Integrated UPS for power failures or voltage fluctuations
- ▶ Stop Category 1 emergency stop safety circuit per DIN EN 60204-1 supported

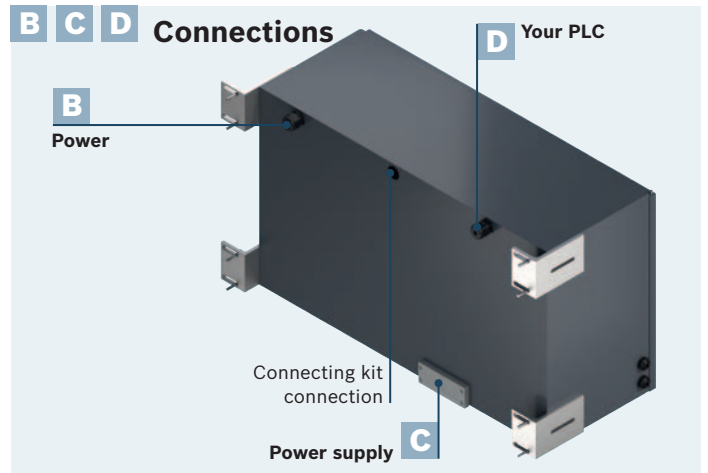

- ▶ Various connection options for tailored uses

## E Mounting bracket



- ▶ For mounting the control cabinet to the base frame

## F Door lock



- ▶ For securing the control cabinet door

## G Main switch



- ▶ Simple operation via main switch
- ▶ You are responsible for installing emergency stop switch and grounding

## H Filter and fan

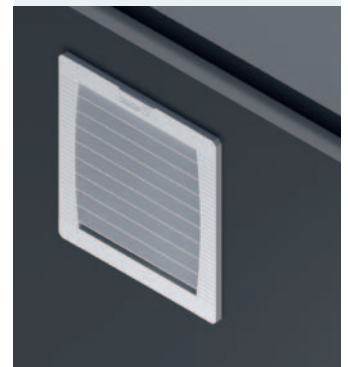

- ▶ Ensure an optimal control cabinet environment

## Power supply set



- ▶ For powering section or curve modules
- ▶ Vertical or horizontal mounting on the base frame

Section and curve modules are powered by corresponding power supply sets. The number of power supply sets needed is determined by the number of workpiece pallets and modules used.

Sets should be placed either all horizontally or all vertically along the entire system.

### Accessories

#### Recommended accessories

- ▶ Connecting cable with min. cross-section of  $3 \times 1.5 \text{ mm}^2$  (incl. protective conductor) for 200–230 V AC connection to control cabinet. You are responsible for complying with country-specific regulations/requirements on connecting cables and routing.
- ▶ Connection cable for PLC monitoring (24 V)

### Delivery information

#### Included in delivery

- ▶ Plug connector, cable gland, incl. installation cable for installing on section and curve modules
- ▶ Fixing plate, incl. fastening kit

### Condition on delivery

- ▶ No assembly required

### Ordering information

Product designation	Packaging unit	Material number
28 V power supply	Set	3 842 559 435

### Technical data

<b>Material number</b>	<b>3 842 559 435</b>	
<b>Properties</b>		
Material	Aluminum, nickel-plated brass, PA, PUR	
<b>Additional information</b>		
Line voltage (input)	V AC	200–230
Supplied voltage (output)	V DC	28
Max. power	W	1316
Min. number of power supplies	Units per system	3
Max. number of power supplies	Units per system	Depends on application
<b>Dimensions</b>		
Cable length	mm	1500

### Calculating max. number of power supplies

- Section module input power x no. section modules
- + curve module input power x no. curve modules
- + workpiece pallet input power x no. workpiece pallets

---

Max. power supply output

### Dimensions

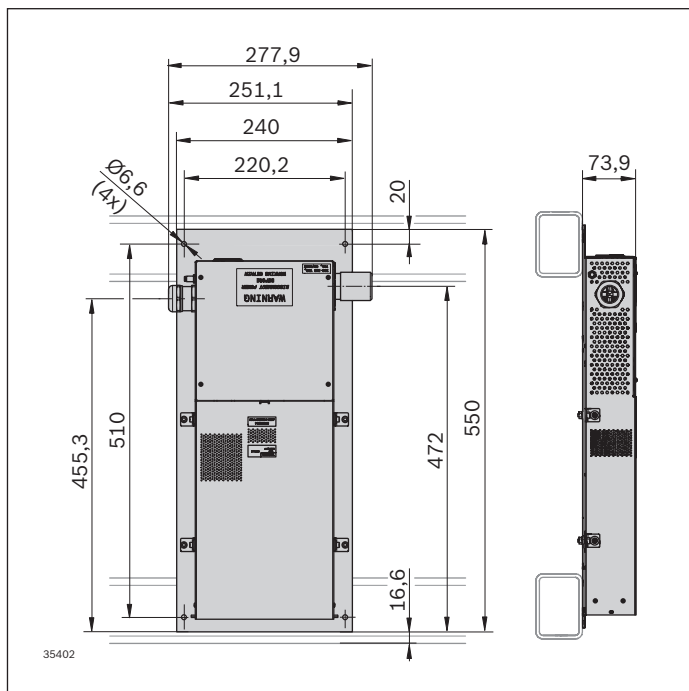

## Control cabinet

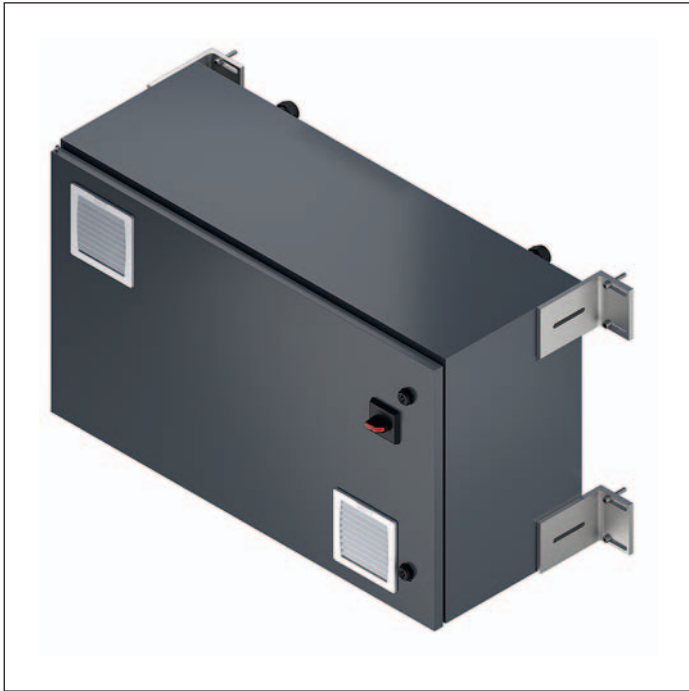

- ▶ Supports Stop Category 1 emergency stop safety circuit per DIN EN 60204-1
- ▶ Two versions:
  - EU
  - NA
- ▶ With uninterruptible power supply (UPS)
- ▶ PLC interface: PROFINET, Ethernet/IP, EtherCAT, etc.
- ▶ With filter and fan for control cabinet climate control

### Notice:

To connect to your PLC, an interface module is required that easily clips into the module holder in the control cabinet. The module holder can hold up to two interface modules for more interfaces.

The controller in the control cabinet assumes control and monitoring of each module and workpiece pallet. The optional interface module offers flexible connections for your standard industrial PLC.

You can integrate emergency stop safety circuits using the existing safety relay to ensure the necessary system safety.

Connecting cables can be inserted both from the side and from below. A UPS powers the modules with 24 V DC in the event of a power failure to allow system data to be saved.

### Accessories

#### Required accessories

- ▶ Interface module (PROFINET, Ethernet/IP, EtherCAT, etc.)
- ▶ Control cabinet connecting kit

#### Recommended accessories

- ▶ Connecting cable for you to install power, PLC, AMpro

### Delivery information

#### Included in delivery

- ▶ Connecting kit: ferrites, network cable, cable protection hose, cable (24 V), grounding cable, network coupler, fastening kit
- ▶ Circuit diagram
- ▶ Controller (i5 processor), uninterruptible power supply (UPS), all necessary electrical components for system connection, incl. fastening kit

The units are available in different country variants:

- ▶ EU: connect up to 24 power supplies
- ▶ NA: connect up to 12 power supplies

#### Condition on delivery

- ▶ Control cabinet: no assembly required
- ▶ Interface module connecting kit: assembly required



## Ordering information

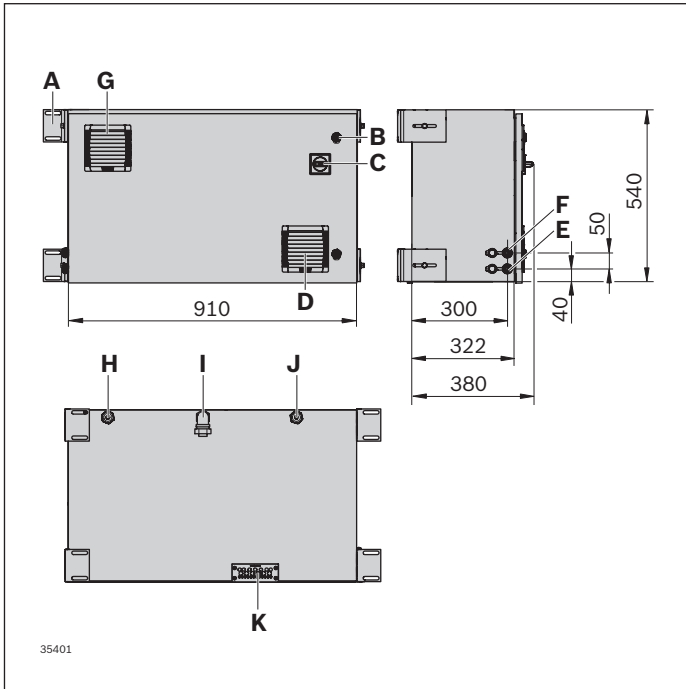

Product designation	Material number
Complete control cabinet (EU)	3 842 559 462
Complete control cabinet (NA)	3 842 559 459

- A Mounting bracket
- B Door lock
- C Main switch
- D Fan
- E PLC controller connection
- F AMpro connection
- G Filter
- H Power port
- I Connecting kit connection
- J PLC controller connection (optional)
- K Power supply connection

## Technical data

Material number	3 842 559 462	3 842 559 459
Country classification	EU	NA
<b>Properties</b>		
Weight	kg	70
Material	Painted sheet steel (RAL 7024), PA, filter (RAL 7035)	Painted sheet steel (RAL 7024), PA, filter (RAL 7035)
<b>Additional information</b>		
Line voltage (input)*	V AC	230/400 3P + N + PE
Supplied voltage (output)	V AC	230
Uninterruptible power supply (UPS)	V DC	24
Line amperage (based on number of power supplies)	A	55
Uninterruptible power supply (UPS)	A	10
Frequency	Hz	50

\* N = neutral conductor, PE = protective earth conductor

**Ordering information**

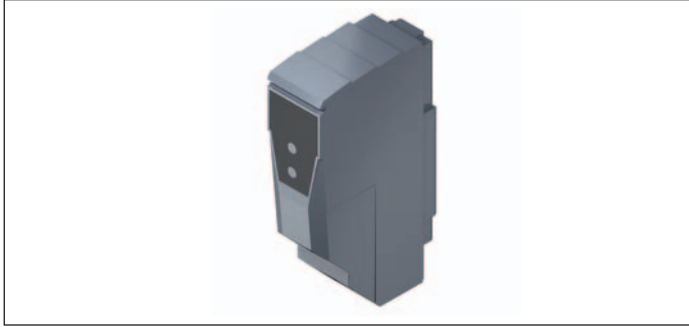

Interface module Product designation	Material number
Ethernet	3 842 559 444
PROFINET	3 842 559 445
EtherCAT	3 842 559 446

**Technical data**

Material number	3 842 559 444	3 842 559 445	3 842 559 446
<b>Properties</b>			
Weight	kg	0.06	0.06
Material	PVC	PVC	PVC

**Ordering information**

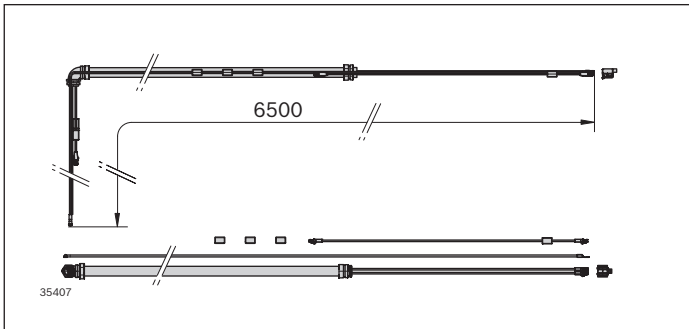

Product designation	Material number
Control cabinet connecting kit	3 842 559 449

**Technical data**

Material number	3 842 559 449
<b>Properties</b>	
Weight	kg
Material	Galvanized steel, PVC



# Control

---

**AMpro** **6-6**

---

**Function modules** **6-7**

# ActiveMover – Control system

## Easy, integrated, open

During planning, it is important to take into account specific requirements, targets and priorities. Complex assembly processes often require a very flexible system, which our control components allow to perfection.



### Benefits of its special features:

- ▶ **Simple:** Commissioning/parameterization, monitoring of the ActiveMover transfer system and even troubleshooting are all done with the AMpro configuration software, and require no programming knowledge.
- ▶ **Integrated:** The controller assumes control and monitoring of the entire system, reducing programming effort for the application. Integrated collision control prevents workpiece pallets from touching. It also ensures safe transport and protects your products.
- ▶ **Open:** ActiveMover offers an open interface for many popular PLC architectures. Using ready-made function modules, you can simplify your application programming to optimize processes in the assembly line.



**A** **Controller**



- ▶ Integrated in control cabinet
- ▶ Controls workpiece pallet movement based on PLC commands
- ▶ Monitors workpiece pallet position based on the data recorded by the measuring system
- ▶ Prevents collisions between workpiece pallets
- ▶ Notifies the PLC when a workpiece pallet has arrived at its programmed destination
- ▶ Controls and monitors every section and curve module

**B** **AMpro**

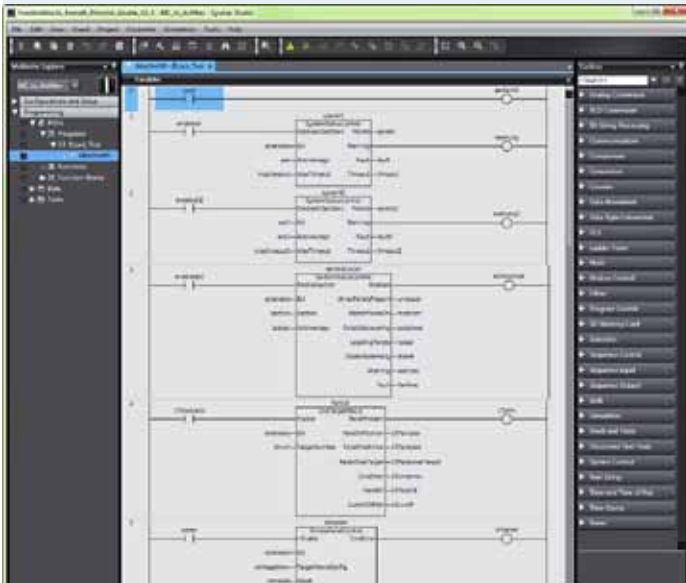

- ▶ Configuration and system diagnostics
- ▶ Allows the system to be configured easily for rapid commissioning
- ▶ No programming knowledge required
- ▶ Can be used as a diagnostic tool for hardware monitoring (module temperature, voltage) or even for workpiece pallet calibration

**C Function modules**

- ▶ Subprograms with a clearly defined data interface between ActiveMover and PLC
- ▶ Simplify PLC programming
- ▶ Come with a data interface programming library for ActiveMover

**D Programmable logic controller (PLC)**

- ▶ Your application controller
- ▶ Sends processes to every workstation in the production line
- ▶ Determines flexible movement parameters (speed, acceleration, offset)/the next destination of every workpiece pallet independently
- ▶ Rexroth function modules assist in programming your application

## AMpro

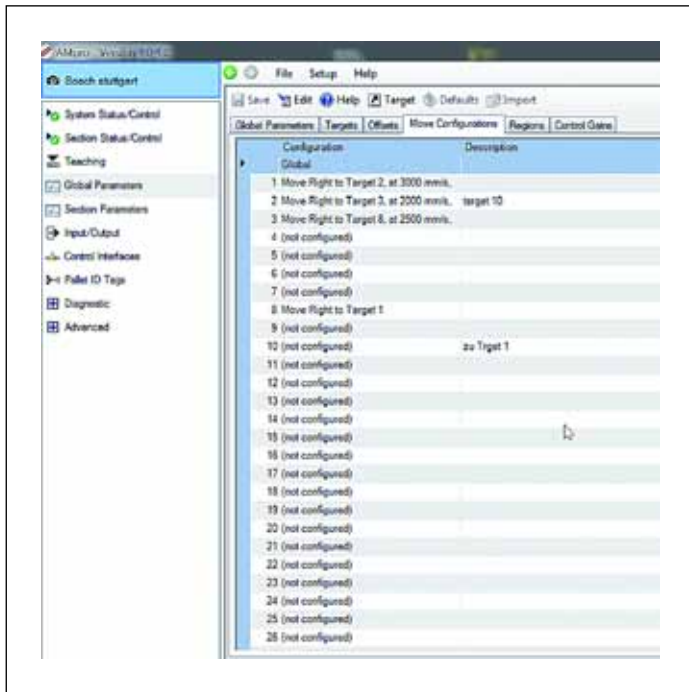

- ▶ Configuration and system diagnostics
- ▶ Allows the system to be configured easily for rapid commissioning
- ▶ No programming knowledge required
- ▶ Can be used as a diagnostic tool for hardware monitoring (module temperature, voltage) or even for workpiece pallet calibration

AMpro is the configuration software for easy commissioning, parameterization and monitoring of the ActiveMover system.

### **ActiveMover, AMpro**

You can contact us directly for the AMpro software:  
[active.mover@boschrexroth.de](mailto:active.mover@boschrexroth.de)



## Function modules

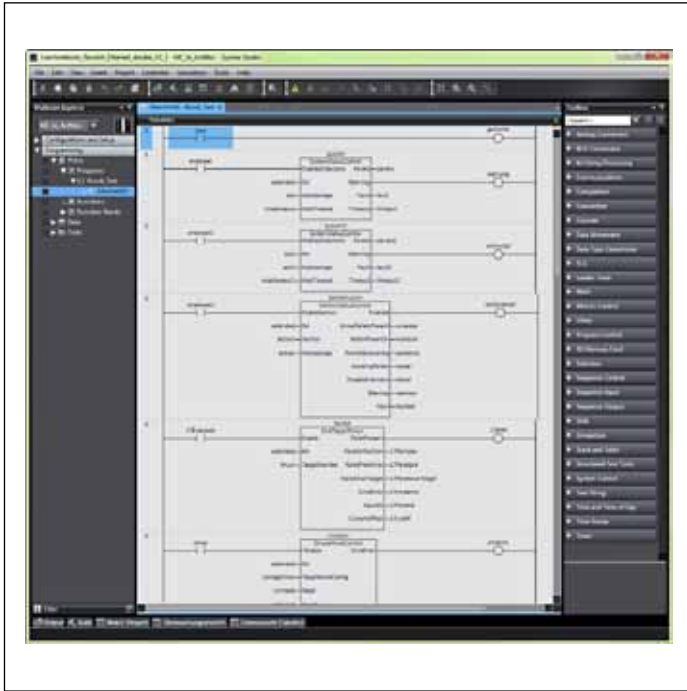

- ▶ Subprograms with a clearly defined data interface between ActiveMover and PLC
- ▶ Simplify application programming
- ▶ Come with a data interface programming library for ActiveMover

For quickly and easily integrating ActiveMover into your PLC.

### **ActiveMover, function modules**

You can contact us directly for the function modules:  
[active.mover@boschrexroth.de](mailto:active.mover@boschrexroth.de)



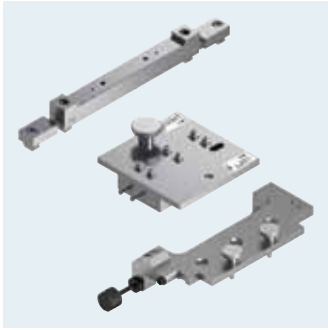

# Tools

---

**Calibration set**

**7-6**

---

**Removal tool**

**7-8**

**7**

# ActiveMover – tools

## Sophisticated, precise, simple

Convenient workpiece pallet changeover and calibration with the right tools. Fast and easy.



### Benefits of its special features:

- ▶ **Sophisticated:** Perfectly matched components allow for smooth interaction when calibrating workpiece pallets
- ▶ **Precise:** Guarantee workpiece pallet repeat accuracy of up to  $\pm 0.01$  mm for a result that stays consistent
- ▶ **Simple:** Quick and easy use of the tools improve process quality

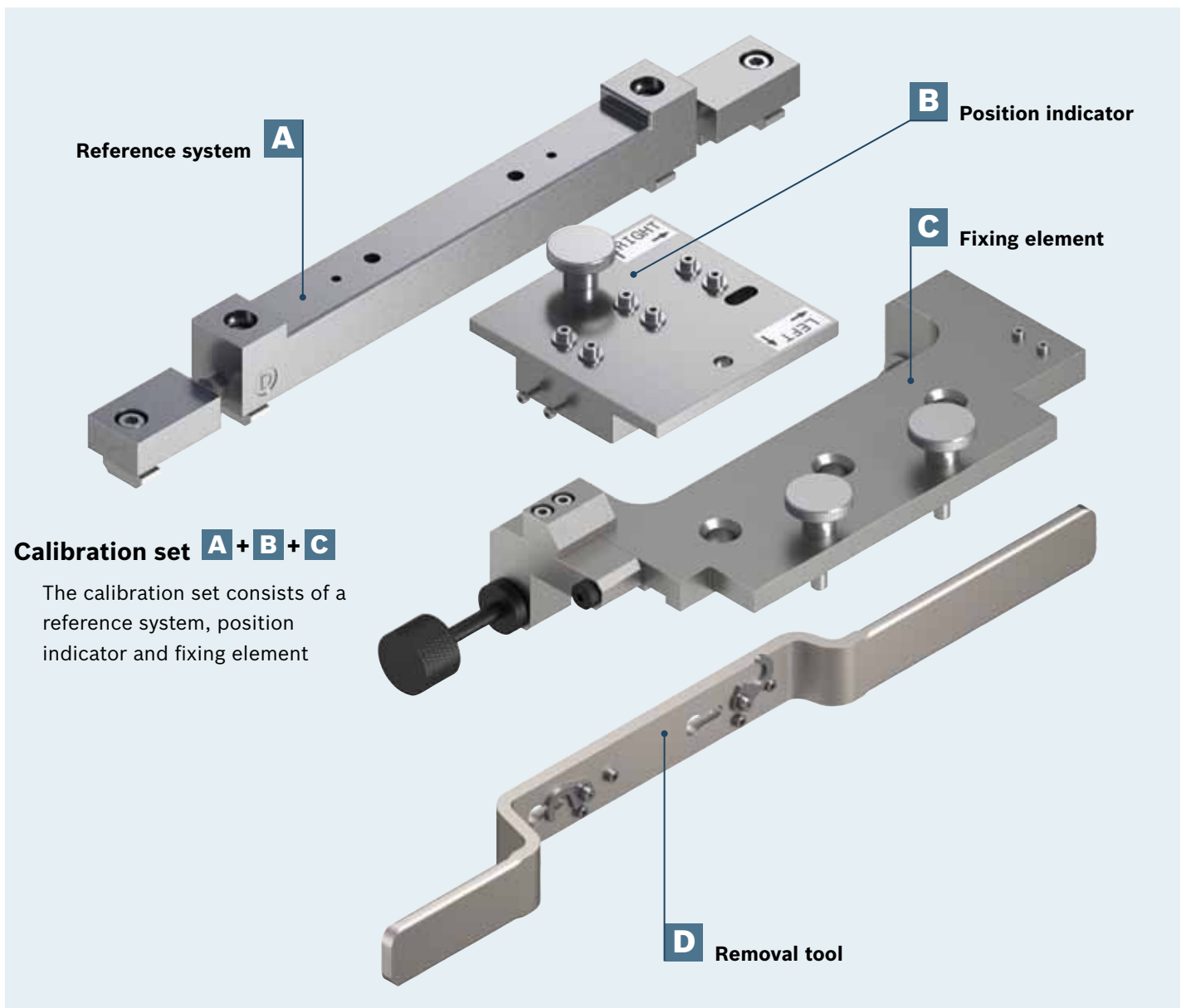

**A** Reference system

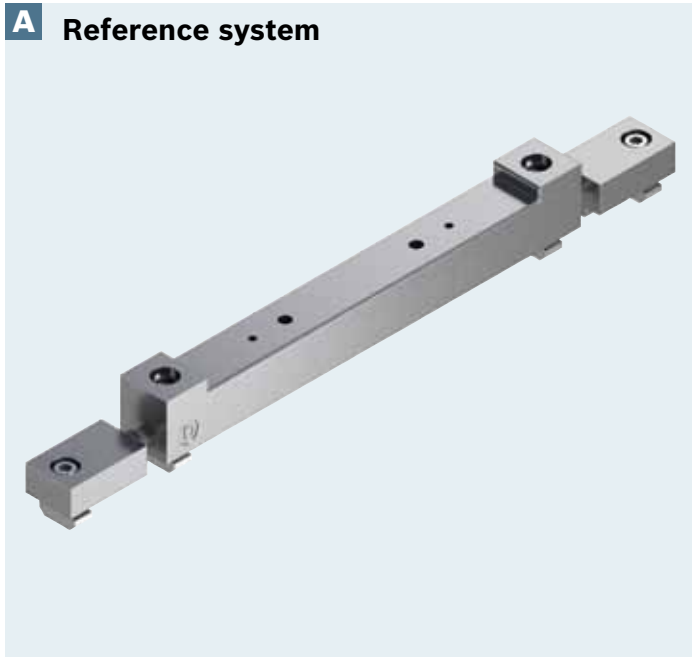

- ▶ Helps calibrate all workpiece pallet magnetic strips
- ▶ Remains after calibration as a reference for new workpiece pallets or magnetic strips when recalibrating the ActiveMover system

**B** Position indicator

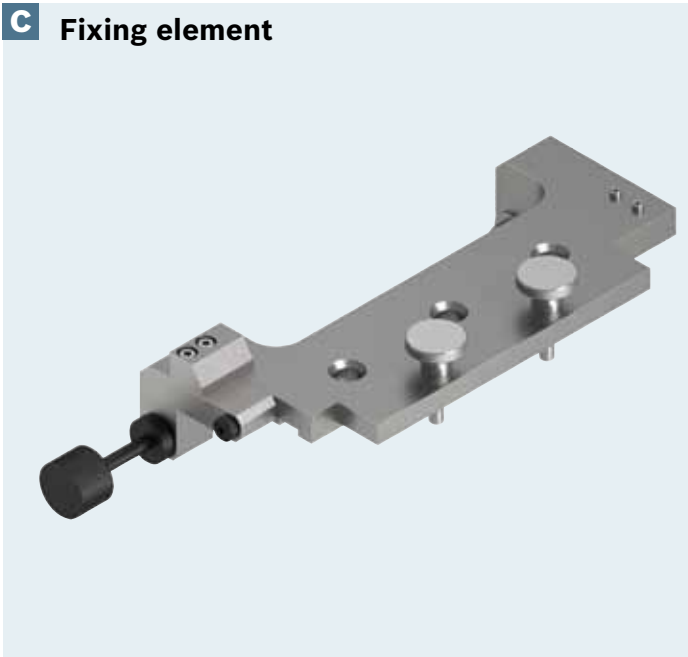

- ▶ Helps precisely position the reference system, which is based on the position of a predefined encoder
- ▶ Is removed after calibration from the ActiveMover system for other applications

**C Fixing element**

- ▶ Positions and fixes the workpiece pallet to calibrate the magnetic strip
- ▶ Is removed after calibration from the ActiveMover system for other applications

**D Removal tool**

- ▶ Once the tool is set and locked in place, the lever action allows the magnetic force to be easily overcome
- ▶ Ensures quick, easy and safe installation/removal of the workpiece pallet
- ▶ Workpiece pallets can be installed or removed anywhere, whether on a section module or a curve module
- ▶ No removal of other components needed

## Calibration set

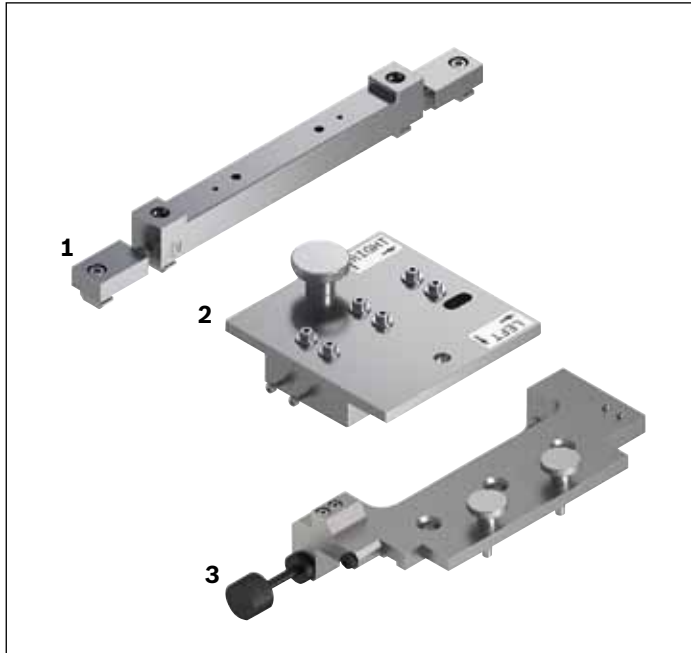

- ▶ For calibrating the magnetic strips on workpiece pallets
- ▶ The calibration set consists of a reference system (1), position indicator (2) and fixing element (3)
- ▶ Reference system (1): helps calibrate all workpiece pallet magnetic strips
- ▶ Position indicator (2): helps precisely position the reference system, which is based on the position of a predefined encoder
- ▶ Fixing element (3): positions and fixes the workpiece pallet in the desired position to calibrate the magnetic strips

The workpiece pallet calibration set is used to calibrate new workpiece pallets. Every component is perfectly matched and easy to use.

### Delivery information

#### Included in delivery

- ▶ Position indicator
- ▶ Fixing element
- ▶ Reference system

#### Condition on delivery

- ▶ Assembly required



### Ordering information

Product designation	Material number
Calibration set	3 842 559 456

### Technical data

Material number	3 842 559 456
<b>Properties</b>	
Material	Aluminum, steel
Weight	2.2 kg

### Dimensions

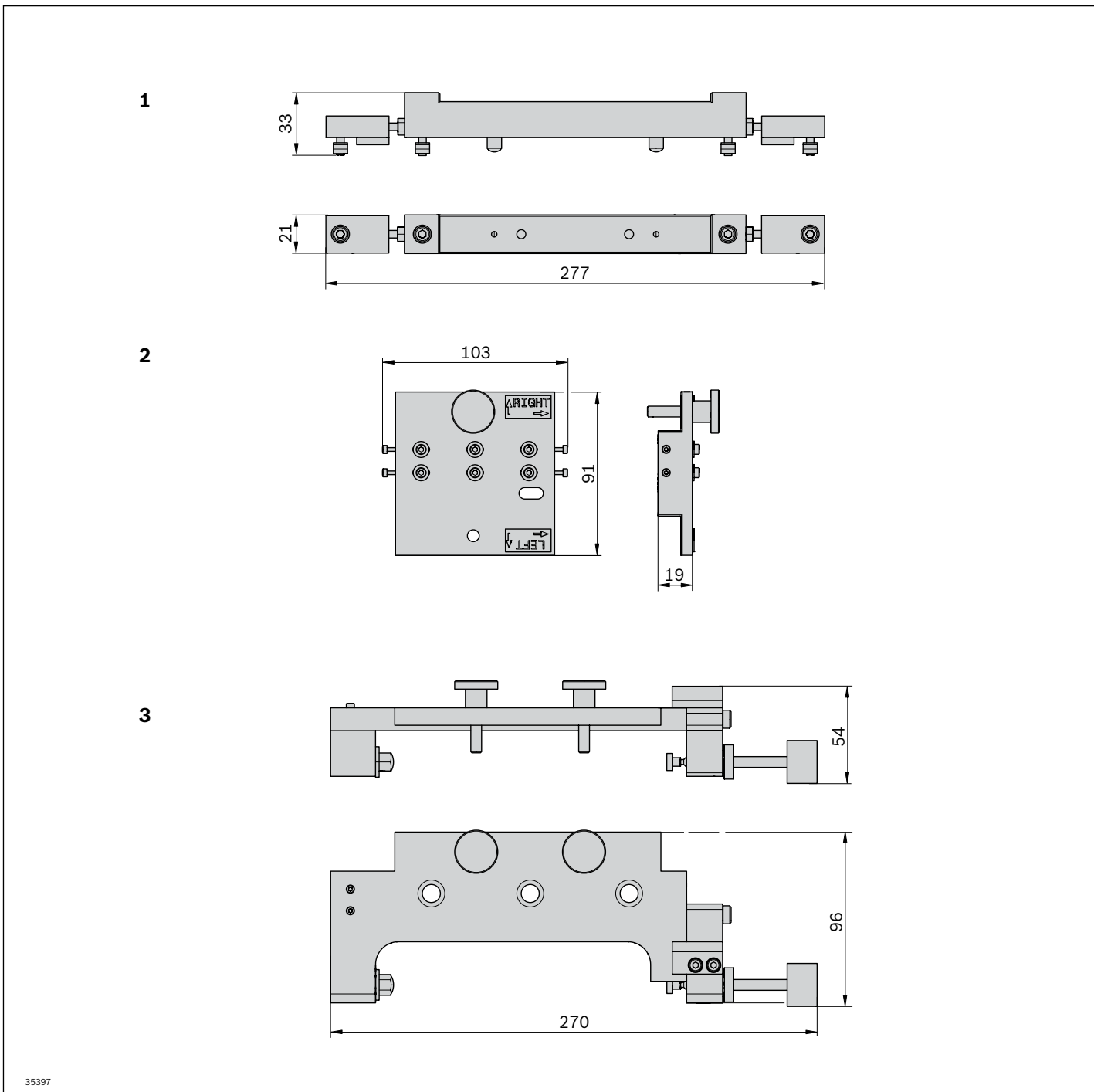

35397

## Removal tool



- ▶ Once the tool is set and locked in place, the lever action allows the magnetic force to be easily overcome
- ▶ Ensures quick, easy and safe installation/removal of the workpiece pallet
- ▶ Workpiece pallets can be installed or removed anywhere, whether on a section module or a curve module
- ▶ No removal of other components needed

The removal tool is used to quickly and easily install and remove workpiece pallets. Workpiece pallets can be replaced on both section modules and curve modules.

### Delivery information

#### Condition on delivery

- ▶ Assembly required

### Ordering information

Product designation	Material number
Removal tool	3 842 559 439

### Technical data

Material number	3 842 559 439
<b>Properties</b>	
Material	Aluminum
Weight	kg 0.8

### Dimensions

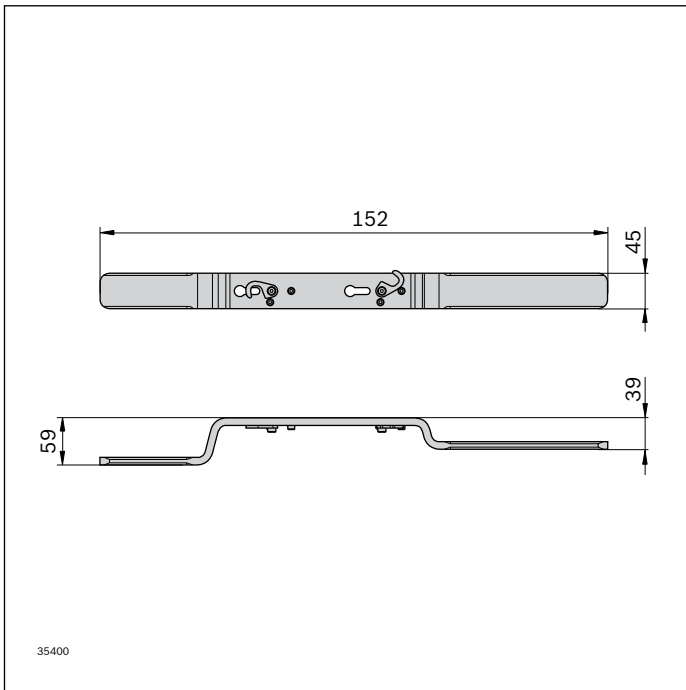



# Material numbers overview

3 842 559 426	3-6	3 842 559 441	2-9	3 842 559 453	4-10
3 842 559 429	3-8	3 842 559 444	5-10	3 842 559 454	4-8
3 842 559 430	3-13	3 842 559 445	5-10	3 842 559 455	4-8
3 842 559 433	2-6	3 842 559 446	5-10	3 842 559 456	7-7
3 842 559 434	2-6	3 842 559 447	2-9	3 842 559 459	5-9
3 842 559 435	5-7	3 842 559 449	5-10	3 842 559 462	5-9
3 842 559 438	3-10	3 842 559 450	4-6		
3 842 559 439	7-8	3 842 559 451	4-6		
3 842 559 440	2-9	3 842 559 452	4-10		

## Index

▶ <b>A</b>		▶ <b>I</b>		▶ <b>T</b>	
Ambient conditions	1-7	Identification system	2-9M	Technical constraints	1-8
AMpro	6-6			Tools	7-1
▶ <b>B</b>		▶ <b>M</b>		▶ <b>U</b>	
Base frame	4-1, 4-6	MTpro	1-9	Uses	1-6
– Fixing plate	4-8	Module holder	3-8		
– Base frame	4-6	▶ <b>O</b>		▶ <b>W</b>	
– Base frame connecting kit	4-10	Operating principle	1-5	Workpiece pallet	2-1, 2-6
▶ <b>C</b>		▶ <b>P</b>			
Components	1-10	Product features	1-3		
Calibration set	7-6	Power supply	5-1		
Configuration and commissioning	1-9	– Control cabinet	5-8		
Curve module	3-12	Power supply set	5-6		
Control cabinet	5-8	▶ <b>R</b>			
Control cabinet connecting kit	5-10	Removal tool	7-8		
Control system	6-1	▶ <b>S</b>			
– AMpro	6-6	Sections	3-1		
– Function modules	6-7	– Curve module	3-12		
▶ <b>F</b>		– Module holder	3-8		
Fixing plate	4-8	– Section module	3-6		
Function modules	6-7	– Section module connecting kit	3-10		

# Notes



**Bosch Rexroth AG**

Postfach 30 02 07

70442 Stuttgart, Germany

[www.boschrexroth.com](http://www.boschrexroth.com)

**Find your local contact person here:**

[www.boschrexroth.com/contact](http://www.boschrexroth.com/contact)

The data specified above only serves to describe the product.

No statements concerning a certain condition or suitability for a certain application can be derived from our information.

The information given does not release the user from the obligation of own judgment and verification. It must be remembered that our products are subject to a natural process of wear and aging.