

Higher productivity and energy efficiency in machining



Improve the efficiency of your machine tool

Competitive pressure and the cost of energy are always on the rise. How can you safeguard your position in the market even better? An intelligent CNC control and drive technologies from Rexroth give you a competitive edge by ensuring that your machine tool operates with ultrahigh productivity and efficiency.

Increased productivity

You can achieve maximum production rates when all of your control and drive technologies are working together at their highest potential and as efficiently as possible. Intelligent CNC controls combined with electromechanical and hydraulic drives by Rexroth turn this dream into a reality. What's more, they are easy to use and program. That considerably shortens productive and idle times in your production processes and increases productivity.

Increased energy efficiency

From design and daily operations to updating equipment, there are many ways to permanently improve your equipment's energy consumption. You can use our solutions to monitor how much energy your processes, machine components and tools are using. Rexroth pursues a comprehensive approach with its 4EE systematic approach, which takes the complex dynamics used among the technologies employed in the machine into account, thereby significantly improving energy efficiency.

Improved user friendliness

Our CNC operating and programming interfaces are intuitive and easy to use. Our standardized operating concept is clearly structured and gives you quick transparency when it comes to your equipment, machines and processes. Selected processes can be clearly illustrated using a variety of extensions for systems or specific custom screens. That minimizes training requirements and increases productivity.

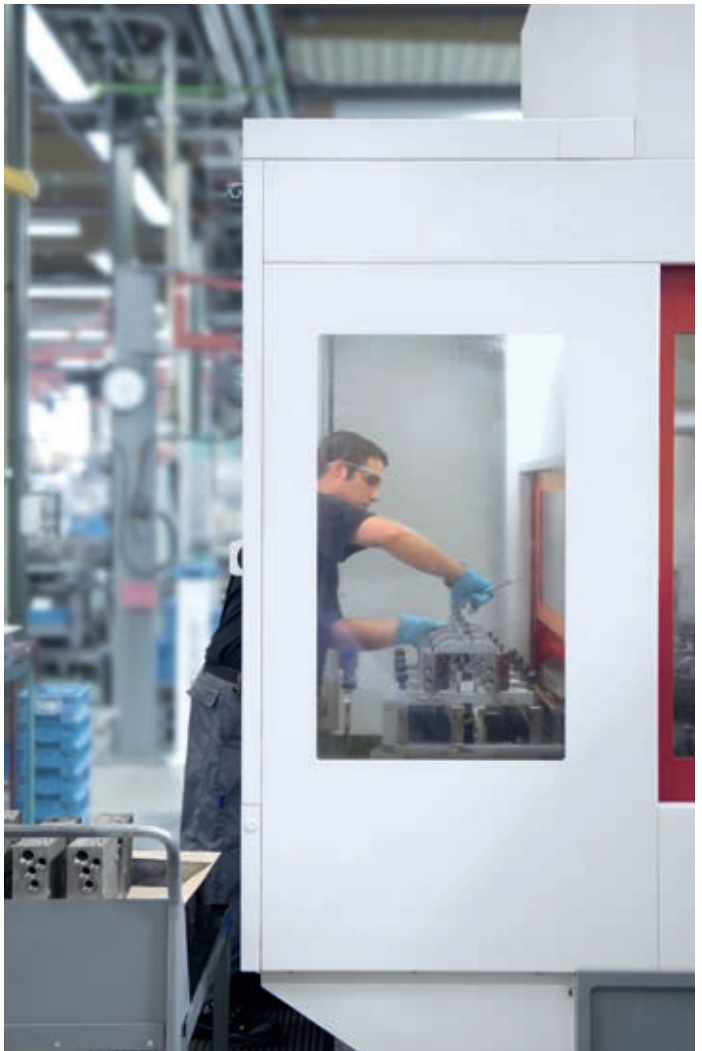

Your path to maximum productivity



i4.0
CONNECTED
INDUSTRY

▲ **IndraMotion MTX opens up new doors for turning, milling, drilling, grinding, and shape cutting.**

Higher speeds and greater economy

Regardless of whether you want to automate a production machine for cutting or control a networked system for large-scale production, the IndraMotion MTX provides you with a tailored CNC control solution. Modular hardware and software and the open system architecture allow our controls to be optimally integrated in many different machine concepts. The exceptional performance of the control and the powerful, highly dynamic drives considerably reduce your machining and downtimes. The IndraMotion MTX cta cycle time analysis tool shows you optimization potential in NC programs and allows you to minimize cycle times and further improve productivity. The IndraMotion MTX rcm remote diagnostics system facilitates maintenance and improves system availability.

Integrated machine safety

Reliable safety technology for man and machine is already integrated into our automation solutions. Operating modes such as “Safe Operational Stop” and “Safely Limited Speed” make it possible to change over, maintain, or inspect the machine without having to switch it off. What this means to you: You do not have to completely restart the system afterwards – for better productivity and economy.

Industry 4.0: Connected Automation

Machinery, sensors, and software are combined to form a digitally connected factory. The result is a wide range of benefits across the value chain: greater productivity, quality control in real time, and lower energy needs. Coordinated components and concepts for Industry 4.0 enhance transparency and efficiency in manufacturing. As a result, competitive advantages for customers are created.



Rexroth 4EE – your solution for greater energy efficiency



Competency across all technologies

You can optimize your energy efficiency in all phases of the machine life cycle. Isolated individual measures implemented in complex systems typically lead to only minimal success.

Rexroth understands your requirements and knows how you can leverage the potential of all technologies. Whether it be electrics, hydraulics, individual components, or integrated solutions, our decades of experience has made us familiar with a wide range of complex dynamics. Our systematic 4EE approach helps you identify and exploit all areas in which energy can be saved, from design, to operation, through to modernization.

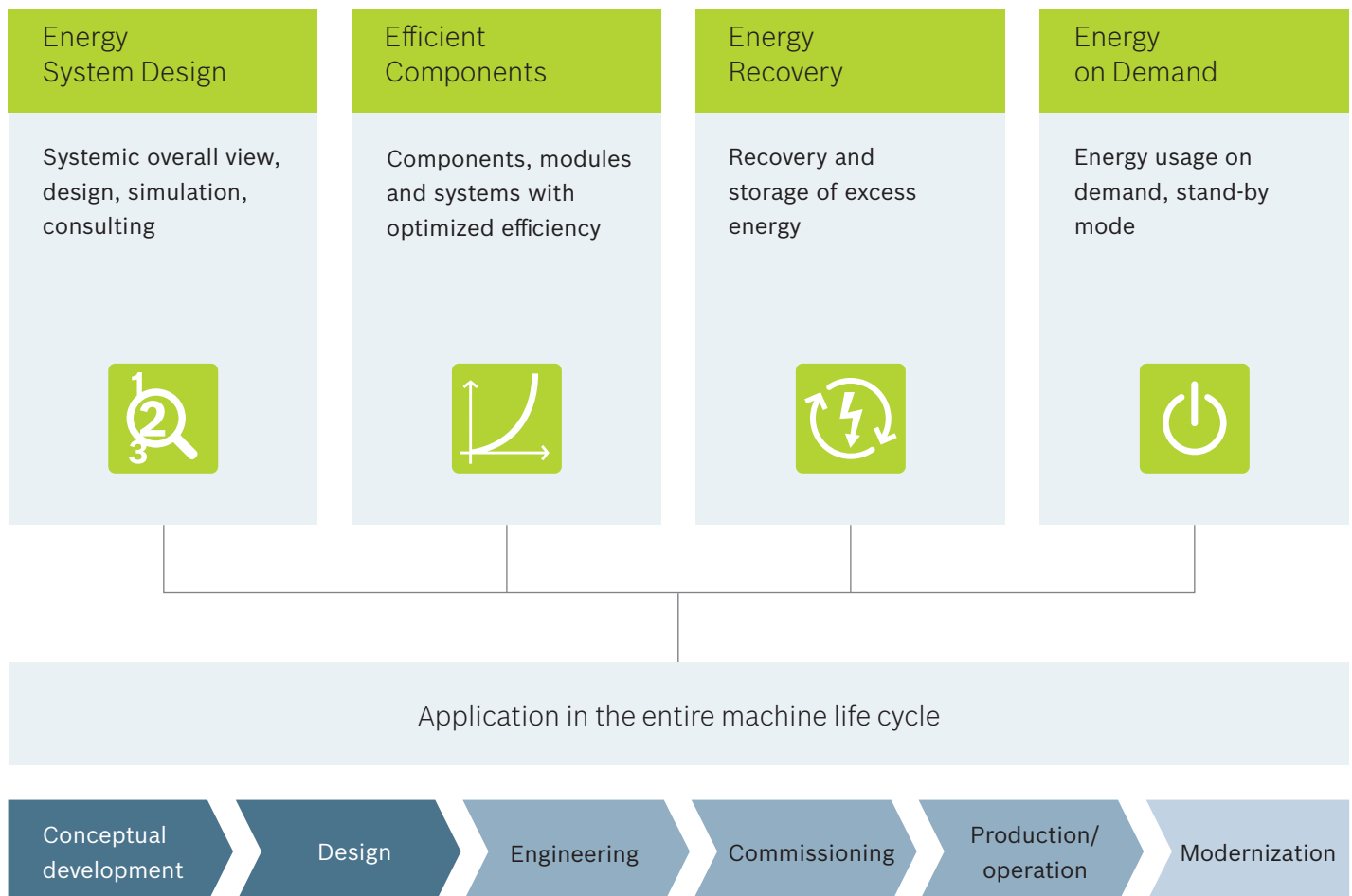

Each stage of the machine life cycle presents different opportunities for implementing energy-efficiency measures.

Innovations that help you save money



IndraMotion MTX ega – for identifying peak energy consumption

How can you minimize the energy consumed by your machine tool? The IndraMotion MTX ega shows you. Integrated directly in the NC kernel of the CNC control, it maps the energy consumption of process segments, components, and tools. An invaluable resource for commissioning and during operation.

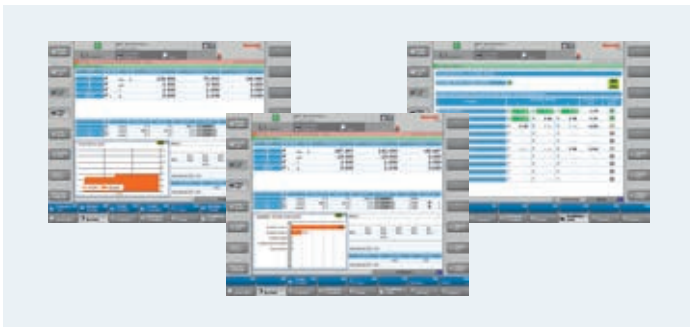

IndraMotion MTX – standby functions – Power as required

Your system will become even more efficient with the standby functions provided by IndraMotion MTX. The entire machine or parts of it can be deactivated (manually or automatically) in line with production sequences.



Sytronix – saving energy with variable speed

Variable-speed pump drives from the Sytronix series lower your operating costs for providing hydraulic pressure by actively controlling power consumption. As soon as a process no longer requires full capacity, the electric drive reduces the speed of the pump motor. The result: Your system operates much more efficiently and quietly.



IndraDrive – intelligent recovery

IndraDrive, the electric drives from Rexroth, impress with their innovative way of recovering energy. Depending on requirements, the system will buffer, redistribute, or recover energy. The compact IndraDrive Mi drive system combines a drive controller and motor in a single unit. This reduces the time and effort required for wiring and control cabinet cooling.

Performance components, modules and systems for your perfect system solution

The comprehensive product portfolio from Rexroth, which encompasses a wide range of technologies, allows you to conveniently design the optimal system solution for your specific task. In so doing, you benefit from a maximum of productivity, energy efficiency, and user friendliness.

Electrical controls

At the control level, IndraMotion MTX meets all requirements, from machine tools to complete high-production systems. It manages up to 250 axes in as much as 60 NC channels. The exceptional performance ensures ultrahigh precision in all applications – down to the nanometer.

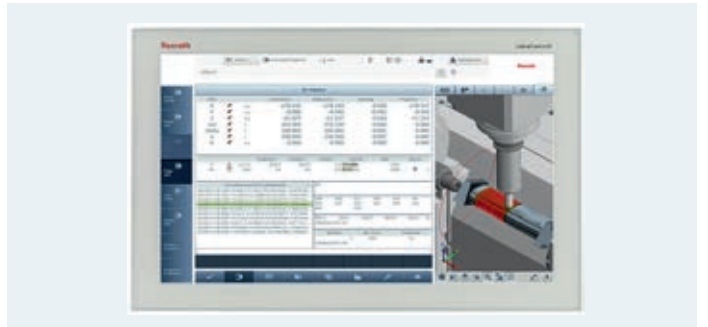

Hydraulics

In machining applications, the hydraulic drives provide for maximum precision during tool movement, while clamping devices hold workpieces in place. Whether it is hydraulic controls, power units, blocks, valves, cylinders, pumps, motors, or filters that you are looking for, we have the solution you need in our diverse range of products.



Electric drives

Our vast selection of servo drives and frequency converters, as well as linear, high-speed and torque motors, allow you to master all tasks. You profit from the benefits of certified "Safety on Board" technology and integrated motion logic for process-driven control. A wide variety of interfaces is available for individual communication with the CNC control and peripheral devices.

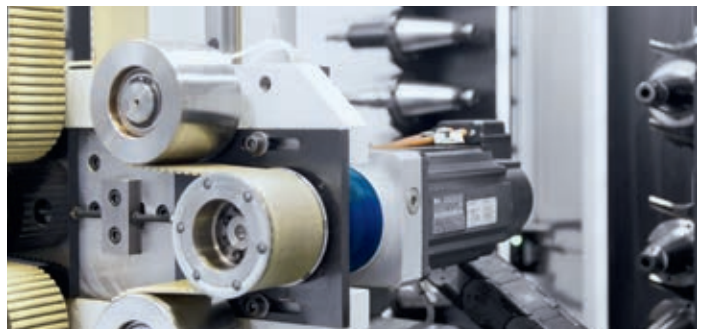



Linear and assembly technology

Guiding and moving with precision – with ball screw assemblies, profiled rail systems, and linear bushings and shafts as well as transfer and handling systems from Rexroth. The performance components are robust, highly precise in operation, and designed for energy-saving motion.



Cooling lubricant technology and chip transport

You no doubt value low operating costs, ultrahigh energy efficiency, and maximum safety when it comes to transporting, filtering, and cooling. Our cooling lubricant technology facilitates centralized and distributed solutions: Chip transport and filtering systems, cooling lubricant supply systems, and additional components.



Software Solutions (ActiveCockpit)

As an interactive communication platform ActiveCockpit processes and visualizes production data in real time. ActiveCockpit networks IT applications such as production planning, quality data management and e-mailing with the software functionality of machines and plants. The information is the base for decisions and process improvements.

Top technologies that harmonize

Tailor-made CNC solutions

IndraMotion MTX is an open control system for many different applications and materials used in machining. The modular hardware and software simplifies integration in your machine concept while the short PLC and CNC cycles improve your productivity.



Extremely versatile hydraulic power units and variable-speed pump drives

Precision-fitting hydraulic power units are key to achieving energy efficiency with your machine tool. Sytronix pump drives reduce power consumption by actively controlling speed in line with requirements. We are also a “one-stop shop” – even better!



Electric drives to meet every requirement

The modular IndraDrive drives impress in performance and functionality and cover a range of 0.1 to 4 MW. With IndraDrive, you profit from the benefits of integrated motion logic, certified safety technology, comprehensive functions, and the diversity of interfaces.



Motors for ultrahigh dynamics – IndraDyn

The forward-looking, all-inclusive range of motors offers impressive performance and a unique variety of designs, layouts, and capacities. In conjunction with the IndraDrive, you can realize standard and high-end applications – highly dynamic, precise, and reliable.



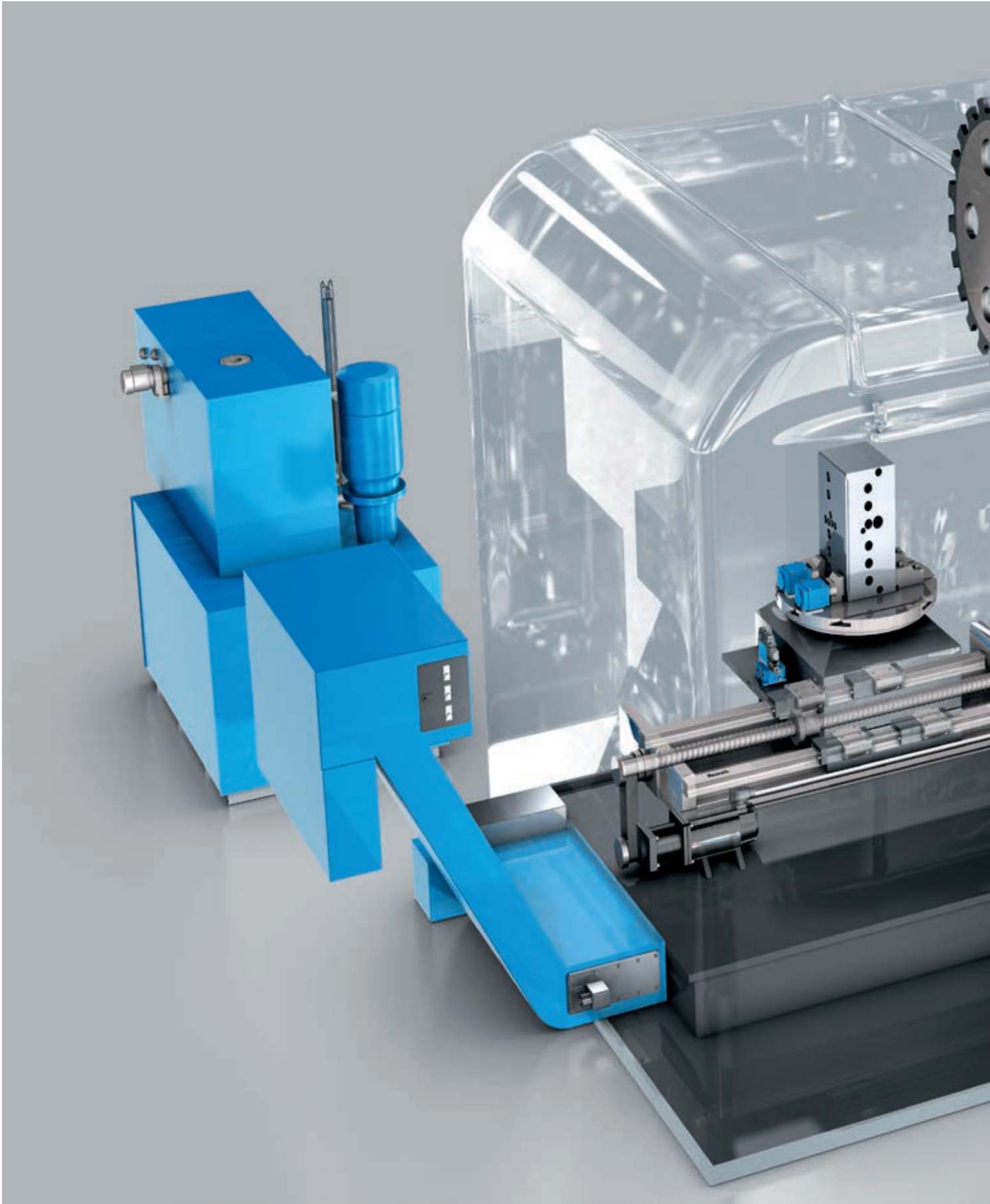

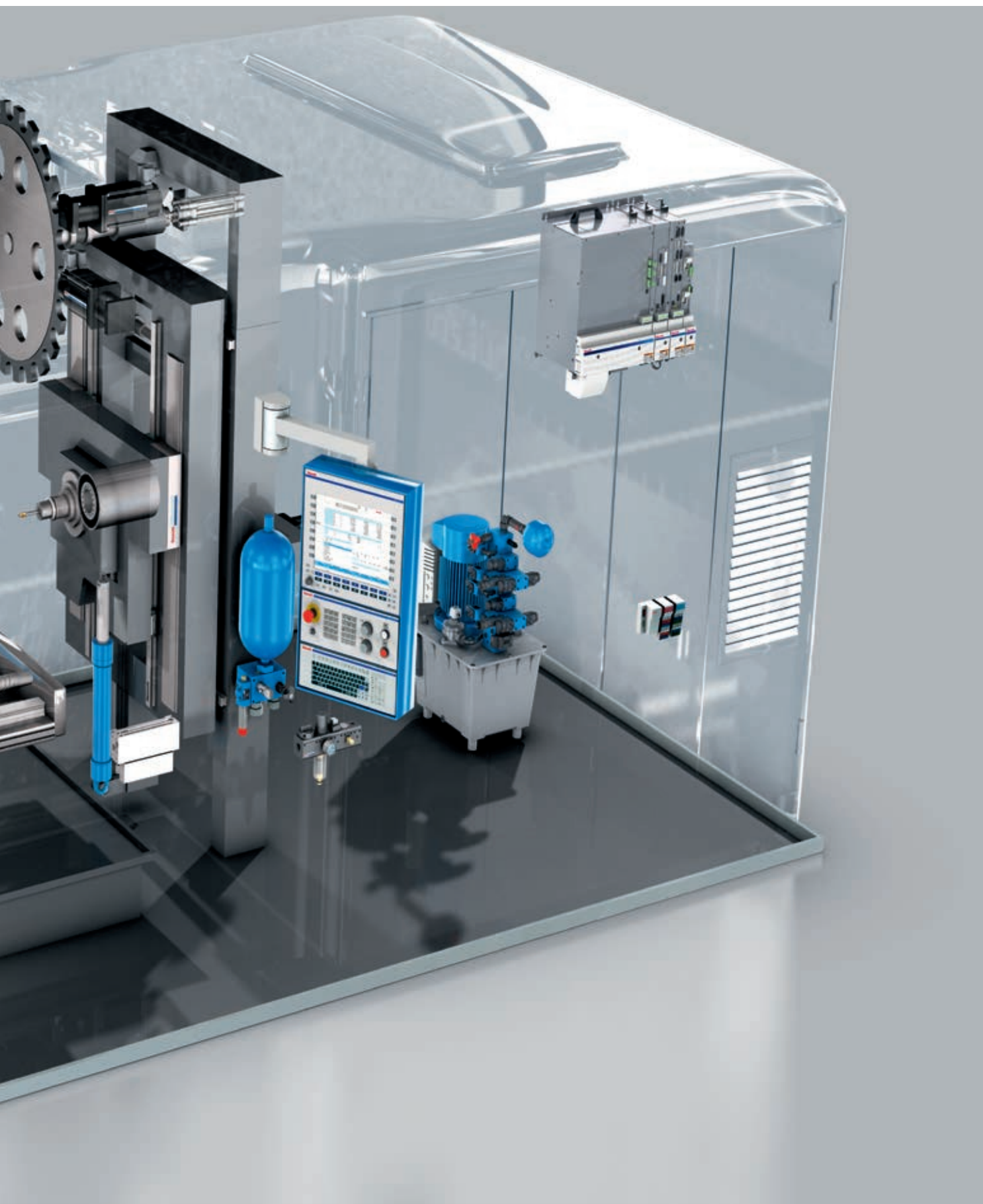



Power meets precision – clamping hydraulics and weight compensation

Clamping workpieces with complex geometries frequently require enormous forces. Reliable hydraulic holding and clamping functions with unique force density ensure the high process reliability you need. Our modular hydraulic system includes the right components for clamping and carrying out highly precise hydraulic weight compensation.

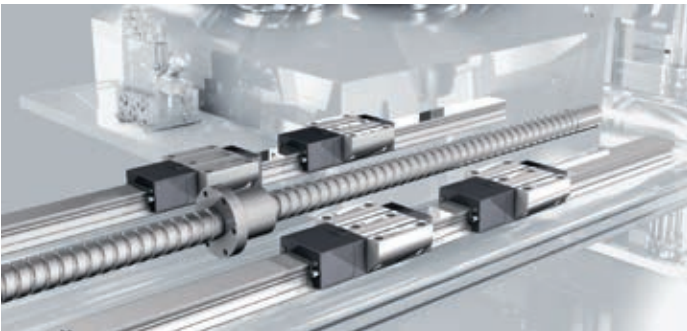

High precision and energy efficiency – linear and assembly technology

Ball screws, in conjunction with roller or ball rail systems, ensure high positioning and repeatable accuracy in all main and secondary axes. Our linear bushings and shafts are characterized by extremely low friction and very smooth running.



Cabinet-free automation

By fusion of drive electronics and motor technology forming an integral unit, IndraDrive Mi contributes to cost reduction not only in terms of the components, but also with regard to installation effort. There is less wiring to contend with, reduced control cabinet sizes and lower cooling requirements.

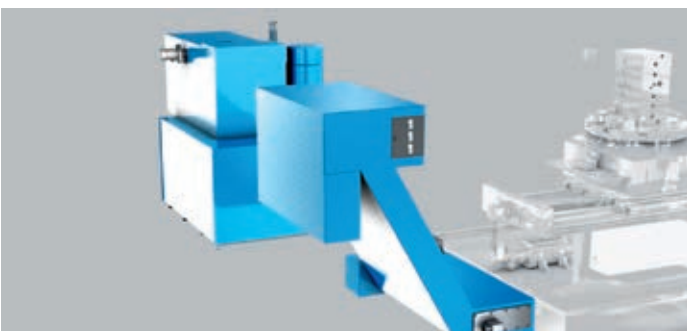

Simply more efficient – cooling lubricant technology and chip transport systems

Higher cutting speeds place very high demands on tool cooling. This is why you should ensure that your coolant has a high purity level. Efficient filtration equipment and chip transport systems offer exceptional performance here. By choosing the right components, you can considerably increase the availability of your machines.

User-friendliness – efficient engineering, easy operation, clear visualization

Engineering – one framework for all tasks

From planning, to programming and parameterization, through to commissioning and diagnostics: The standardized IndraWorks software platform allows you to carry out all engineering tasks quickly and efficiently using a single interface.

A comprehensive library contains the software modules for all components. To add the tools you need, simply drag and drop them onto the workbench.

IndraWorks integrates a PLC compliant with IEC 61131-3, configuration tools for fieldbus communication, and comprehensive diagnostics functions to quickly pinpoint and correct errors during servicing and commissioning.

Operation – simply intuitive

Automation solutions from Rexroth feature scalable hardware components and user-friendly operating software that are perfectly coordinated and meet exactly your requirements.

All applications can be immediately accessed from a single, intuitive interface. Whether you use the mouse, keyboard, or touchscreen, clear menu structures with a minimal number of sublevels allow you call any function very quickly.

Leverage the numerous ways available to document important processes. Logbooks for machine functions and documentation of parameters make critical processes transparent.

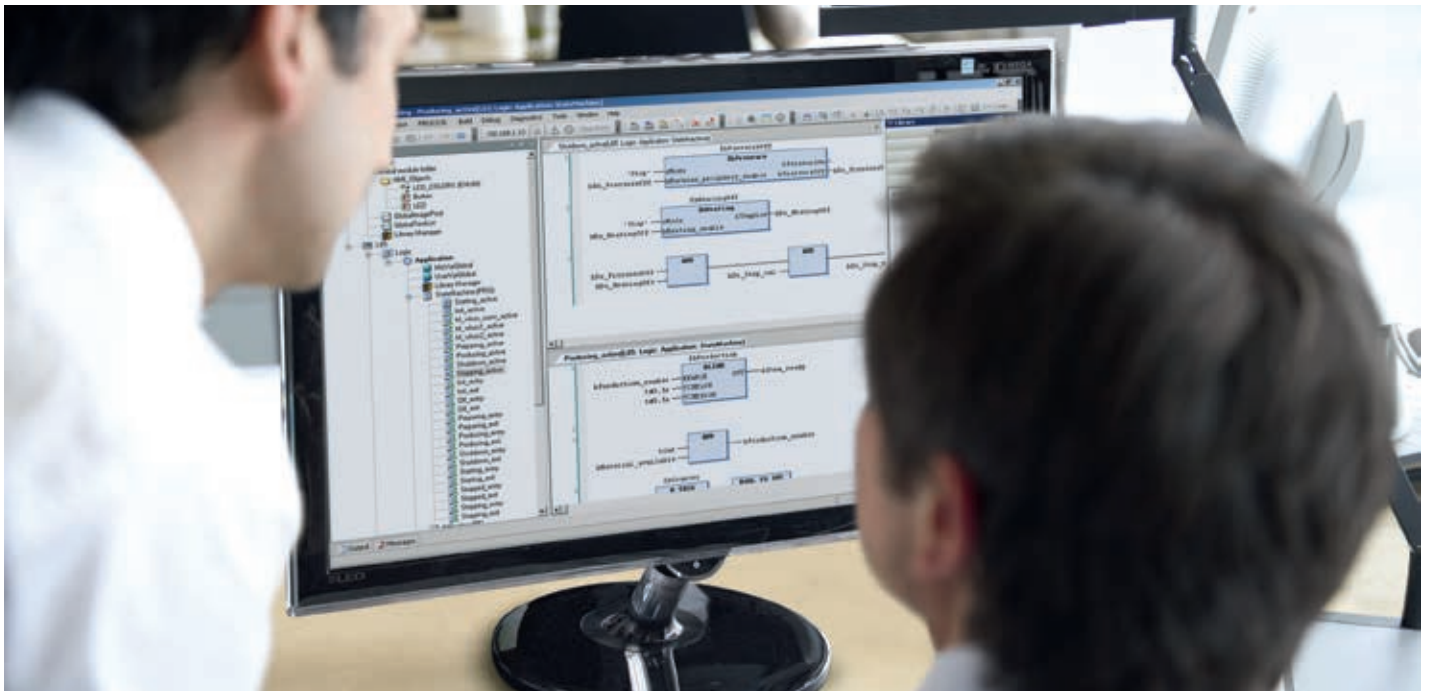

Visualization – the way you want it

What applies elsewhere also holds true for visualization: Innovative concepts and flexibility improve the efficiency of your production. To this end, use our preconfigured standard screens for all areas of operation and visualization and adapt them to meet your specific requirements. Import the 3D CAD modules of your system components for optimal machine display. Structure intuitive menus for easy maintenance and diagnosis with an icon-based system.



▲ IndraMotion MTX offers a comprehensive technology cycle library with a user-friendly interface for standard processing.



▲ System-specific special images are easily created and added to the standard interface with the integrated HMI editor.

Whenever you need expert assistance

Rexroth is your professional and experienced technology partner. We offer long-term support with comprehensive service solutions – solutions that span the entire life-cycle of your machines and systems.

Technical support/help desk

Ask our help desk experts any question you have – 24 hours a day, 365 days a year. Specialists with many years of experience in the field will advise you in programming and configuring as well as diagnosing and resolving problems.

Field service

Do you need help with commissioning or tackling application or functional problems? Our industry experts from field service can travel to you in minimal time. We also gladly assume engineering tasks and carry out preventive maintenance measures.

Repair and spare parts service

You can rely on fast repair and spare parts service should you run into trouble. For quick and fair support in line with ultrahigh quality standards – guaranteed. Rush repair jobs can be carried out on the same day as well as on weekends and public holidays.

Retrofitting/modernization/engineering

Get the most out of your system now and in the future with simple retrofitting measures. We will help you devise a plan, exchange components, and train your personnel.

Machine safety

Our machine safety services encompass providing support for project management, including a risk analysis, and assessing the current state of the machine. After completing the standards-compliant assessment, we propose solutions for optimizing and reducing risk and implement them.

Industry training

In Rexroth training centers or on site at your company: Our training program covering all aspects of automation will turn your employees into technology experts. Our modular training systems convey profound, practical knowledge. You will also find a comprehensive range of e-learning courses on our learning server so that you can improve your know-how when required – anywhere and at any time.



Bosch Rexroth AG

P.O. Box 13 57
97803 Lohr, Germany
Bgm.-Dr.-Nebel-Str. 2
97816 Lohr, Germany
Phone +49 9352 18-0
Fax +49 9352 18-8400
www.boschrexroth.com

Find your local contact person here:

www.boschrexroth.com/addresses

The data specified above only serve to describe the product. As our products are constantly being further developed, no statements concerning a certain condition or suitability for a certain application can be derived from our information. The information given does not release the user from the obligation of own judgment and verification. It must be remembered that our products are subject to a natural process of wear and aging.