

Increase your Productivity with Hydraulic Mold Oscillation Systems in Continuous Casting Machines

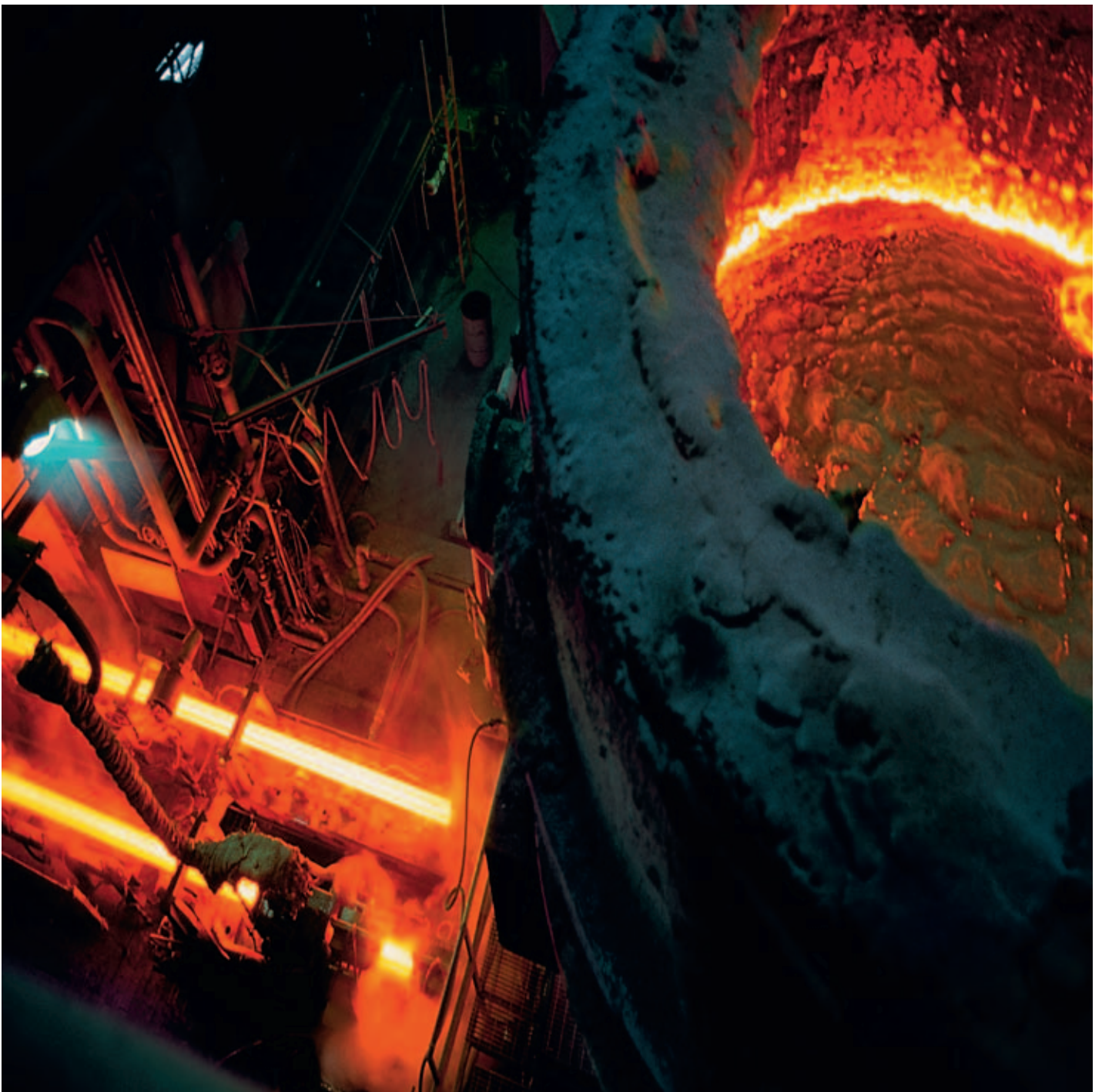



Producing High-quality Steel More Precisely, Efficiently and Sustainably

The demands made on new, heavy-duty steels produced with sparing use of resources are becoming increasingly exacting. And this is also valid with regard to optimized production methods. A relatively simple task with new plants, but this quickly turns out to be problematic when old plants are to be modernized, for it is not sufficient to exchange individual components! Rexroth as system partner supplies tried-and-tested drive solutions for a sustainable increase in productivity.

Increase in efficiency with better oscillation

In continuous casting, one of the most important systems is mold oscillation. Electrohydraulic systems from Rexroth permit an exact oscillation of the mold according to the given curve profile. This results in an improvement of the surface quality of the cast product and in the efficiency of the plant.

Exact and reliable with robust technology packages

Mold oscillation places greatest demands on automation. Production conditions are extremely harsh, exacting safety regulations must be complied with, and masses of many tons must be moved precisely. The technology of drives and control, which has proven in many large-scale projects, allows up to 400 strokes per minute and amplitudes of up to 10 mm for various curve profiles – safely and reliably.

Reliability through system partnership

Complete solutions from Rexroth reflect the application know-how acquired by metallurgy specialists over decades. Right from the start of the project you can rely on a partner who knows all functions involved in continuous casting. He combines hydraulic and electric drives with open controls, which can be integrated into higher level controls without any difficulties. This helps shorten engineering and commissioning times and reduces the failure risk. Proven solutions, which demonstrably increase the productivity in continuous casting machines.

**Quality factor "surface":
More precise mold oscillation improves the surface quality of the cast product visibly and efficiency measurably.**

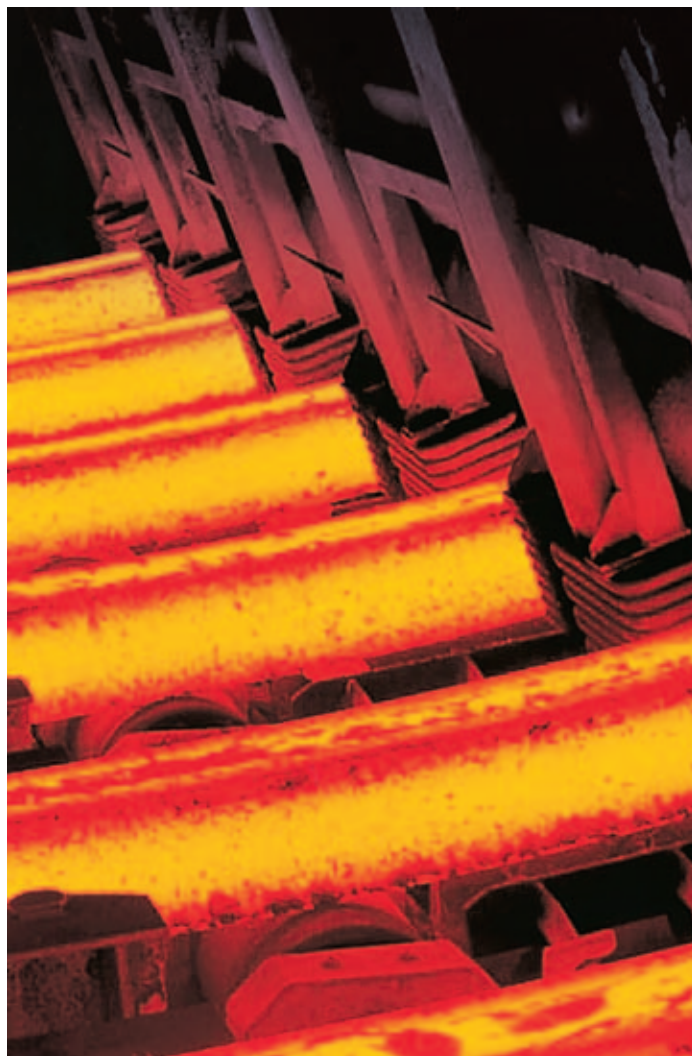

Mold Oscillation in a Continuous Casting Machine

This process forms the basis for optimum surface quality as well as for the productivity and efficiency of the entire plant. Only the use of latest electrohydraulic systems allows the desired exact movement of the masses weighing many tons in accordance with all oscillation parameters.

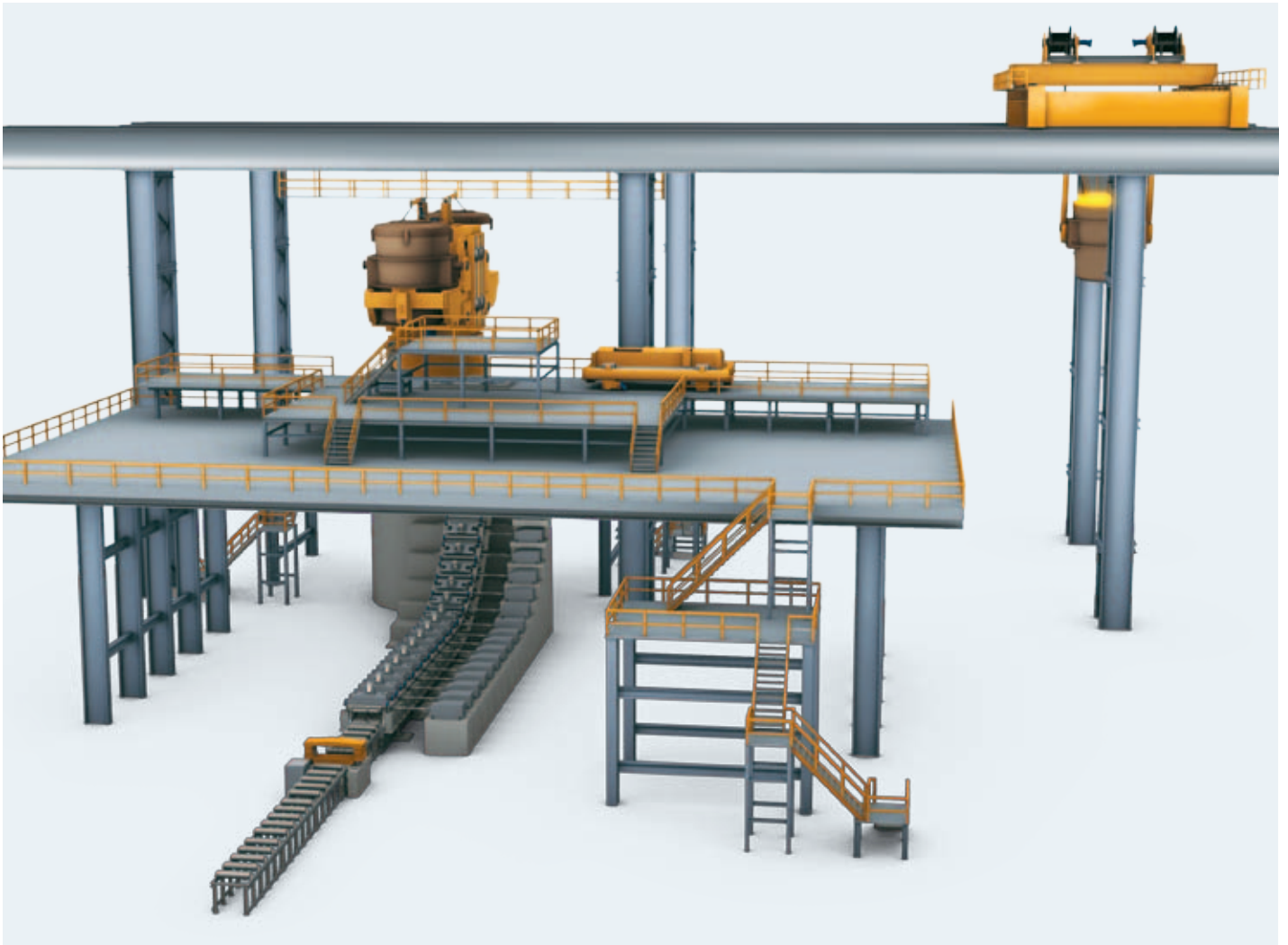

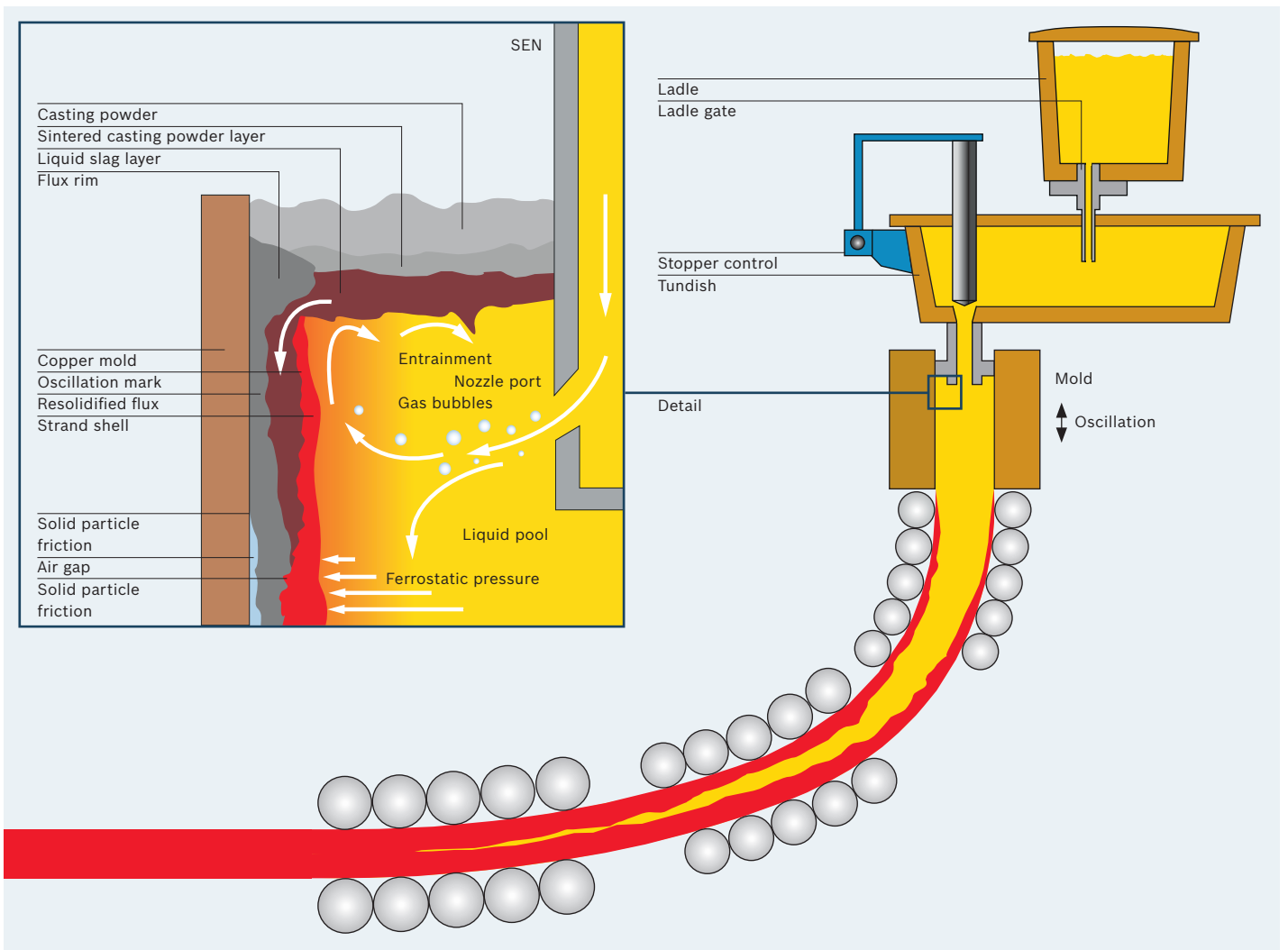

Oscillation promotes the penetration of casting powder at the pool into the gap between the wall of the mold and the strand shell. The molten casting powder acts as lubricant in the contact area between the mold and the strand. This reduces friction between the wall of the mold and strand shell and prevents shell sticking.

Lubrication control by means of optimized mold oscillation is thus an important factor for functional safety and the surface quality of the strand, in particular with high-speed casting.

Two drive technologies – one application

Older plants often employ electromechanical drives, which require complex mechanical conversions when the stroke length is to be changed. In contrast to these drives, hydraulic systems can also perform asymmetric oscillation forms while featuring a unique power density and simple energy accumulation.

The hydraulic rotary drive with secondary control from Rexroth, on the other hand, offers a simple way of retrofitting a conventional drive with electric motor, gearboxes and eccentric. Using this solution, different curve profiles can be realized at variable frequency. Result: highest accuracy and dynamics.

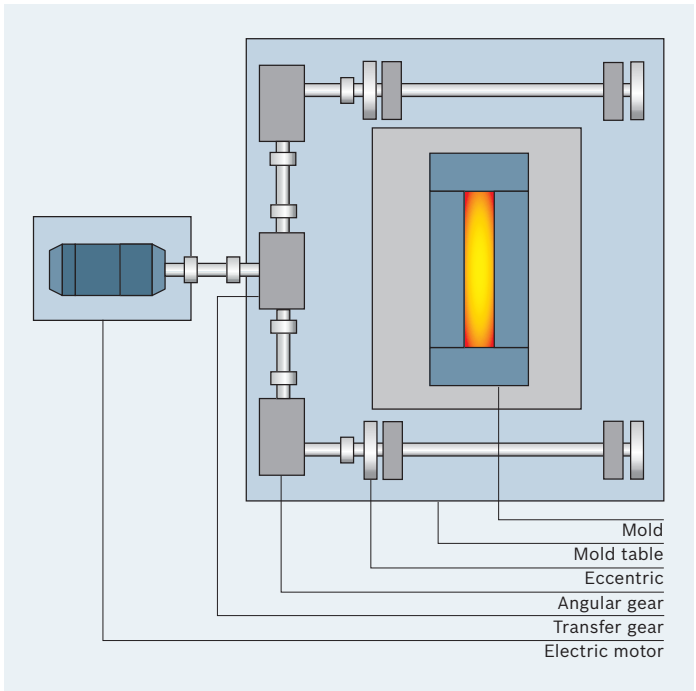

- ▶ At the top: electromechanical drive – at the bottom: hydraulic rotary drive with secondary control
- ▼ Secondary unit A4VSO DS2 variable displacement pump and SYHNC100-SEK.3X digital controller unit

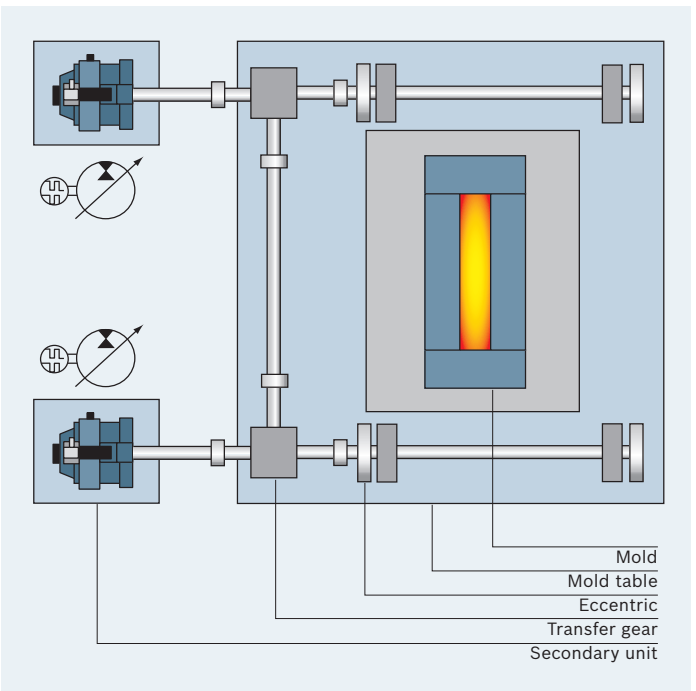

Rexroth System Partnership: Comprehensive Know-how, Proven Components, Easy Integration

Today, continuous casting machines require very precise oscillation as well as great flexibility in terms of stroke and frequency. For this, Rexroth offers a complete, matched drive and control package consisting of components that can be integrated in every control and instrumentation system: from oscillation cylinders through to heavy-duty multi-axis controls with software packages. The result: Oscillation according to the given curve profiles and thus an improvement in the surface quality of the cast product.

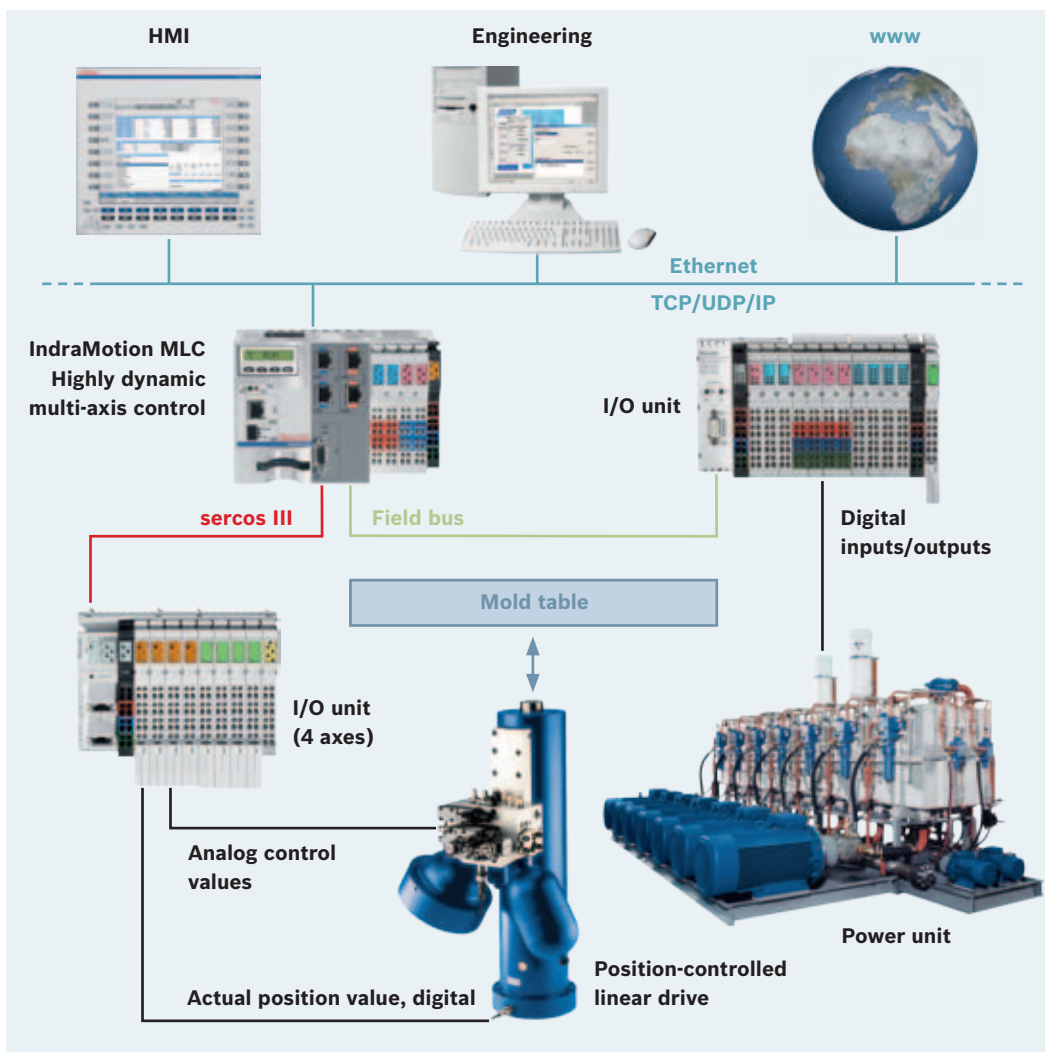

Systematic partnership:
You define the requirements, we supply the suitable components and our expertise.

◀ **System overview:**
Mold oscillation with hydraulic linear drive

The Rexroth Technology Package: From 0 to 400 Strokes/min in Real Time

Moving masses of a weight of several tons precisely at more than 1,000 °C, up to 400 times per minute, in amplitudes of up to 10 mm with a wide variety of curve profiles – Rexroth accomplishes this in real time with the use of the latest advanced electro-hydraulic technology.

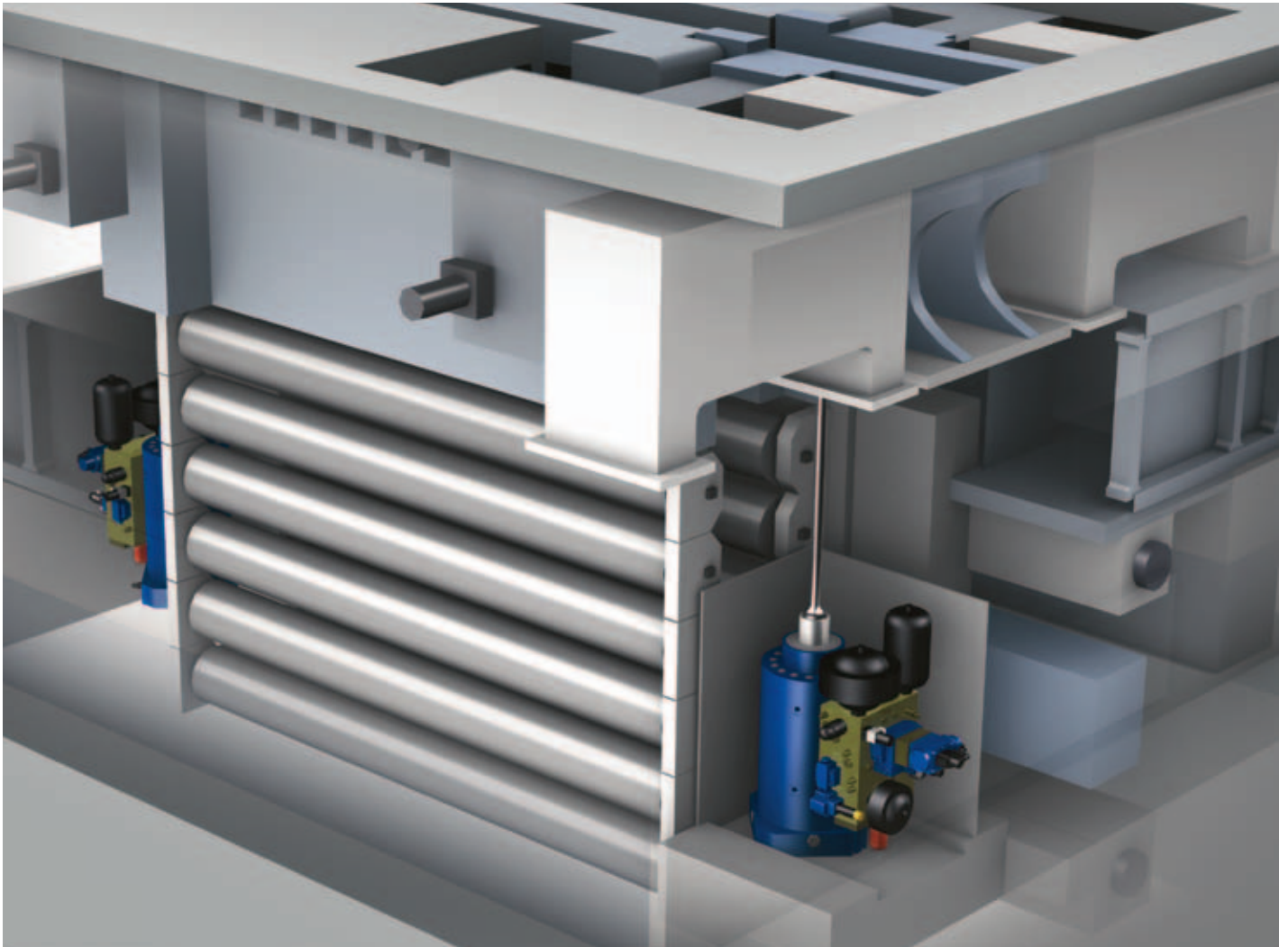

Variable: position-controlled hydraulic linear drives

Hydraulic linear drives allow the complete control of all oscillation variables during casting. Due to this control flexibility, different curve profiles may be applied to optimize the oscillation process. In addition, both, the stroke amplitude and the oscillation frequency, can be varied together with the casting speed during casting.

The essential features of mold oscillation cylinders from Rexroth are extremely dynamic response characteristics, accuracy, a low friction coefficient, high capacity for absorbing transverse forces due to the special support of the piston rod. Moreover, they are characterized by great static stiffness and damping.

If no transverse force loads occur, high-performance cylinders from Rexroth may be used as cost-efficient alternative.

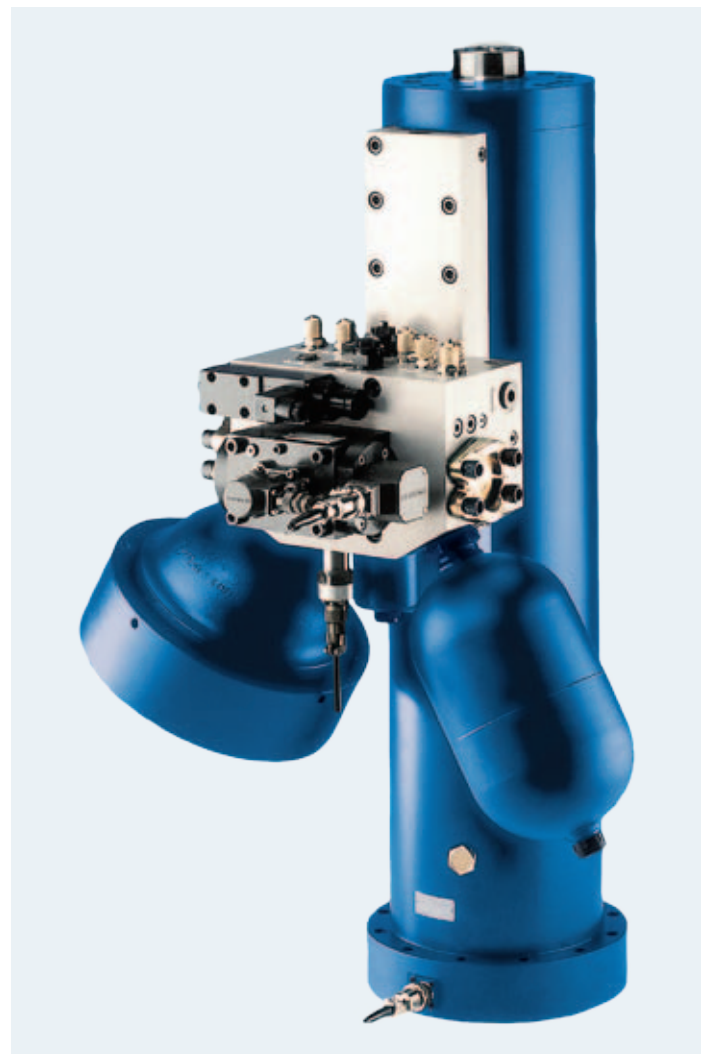
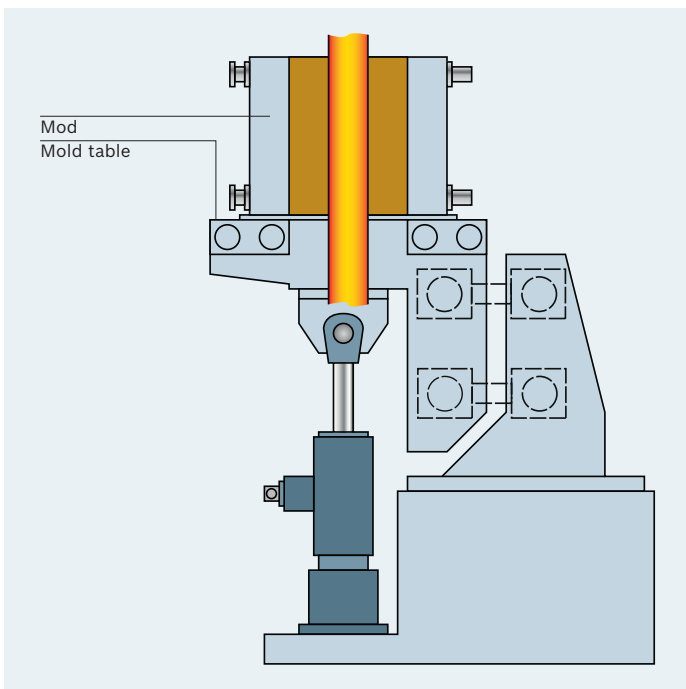

▲ **Compact: the function unit consisting of servo control block and servo-valve as well as diaphragm-type accumulator is fitted directly on the hydraulic cylinder**

Individual Components, one System – Optimally Tailored to Your Requirements



Compact and highly dynamic: Servo control blocks and servo valves

Servo control blocks are compact hydraulic sub-systems and support the excellent dynamic characteristics of the hydraulic drive. The standard version can be adapted to suit the specific requirements. Due to the compact design, the dead volume is reduced to a minimum. To limit the hydraulic force, pressure relief valves are fitted on both sides of the cylinder. The servo-valves are characterized by high dynamics and, at the same time, high flow rates. Further features are the integrated electronics and sensing of the spool position via an inductive position measuring system.

Diaphragm-type accumulator

Mold oscillation is highly dynamic; for this reason, diaphragm-type accumulators can be provided in the pressure and return line near the servo-valve.



- ▲ **Function unit consisting of servo control block and servo-valve**
- ◀ **Servo-valves with central or integrated control electronics**
- ▼ **Diaphragm-type accumulator mounted at the pressure and return line**



Optimally matched: integrated control electronics

All electrical settings are matched by means of the control electronics integrated in the servo-valve. This ensures optimum adjustment of the controller and valve dynamics. Servo-valves from Rexroth show a high response sensitivity as well as very low hysteresis and zero point drift. These valves are therefore excellently suited to controlling mold oscillation.

Robust and reliable drive technology

For safety and insurance reasons, many plants must be operated with HF media. The high-pressure axial piston pump A4VSO version F, which is optimized specifically for use with HF media (HFC), has proven worldwide for these media and pressures up to 315 bar. Rexroth is therefore the only supplier who can offer the same performance data as for pumps operated with mineral oil. Even HFA and HFB fluids can be used, which was demonstrated in comprehensive test series. An important contribution to machine safety.

System-specific power unit

The power unit is the heart of every hydraulic system and has a decisive influence on its productivity and efficiency. We accompany you by providing intensive advice over the entire lifecycle of your system. When dimensioning the power units, we always consider the entire hydraulic system and utilize the most advanced simulation programs. They simulate the special characteristics of fluid power technology realistically and ensure that your power unit will perfectly match your task.



- ▲ A4VSO version F for operation with water-containing media
- ▶ System-specific power units from Rexroth are efficient, silent, safe and are perfectly suited to the task at hand



IndraMotion MLC: Have always a Grip on all Axes with the High-performance Control

Depending on the requirements, the programmable logic high-performance, multi-axis control IndraMotion MLC generates different types of oscillation – as sinusoidal, asymmetric sinusoidal or saw-tooth oscillation. The control is programmed with specific hydraulic control characteristic and offers a comprehensive, freely configurable control concept for all axes, which contains, among others, closed-loop control of pressure, velocity and state.



The control translates parameter changes into commands for the drive axes in real time. The special characteristics of hydraulic control such as closed-loop controls of state, position, pressure/force, and velocity as well as synchronization controls are stored in algorithms, thus simplifying automation.

The control can be used as “standalone” or sub-system, or be equipped with a visualization PC and hooked up to higher-level control systems.

On request, we create the complete visualization for mold oscillation: with process representation, product and machine data, error indication and log, diagnosis and service images as well as trend curves. Rexroth supports, of course, also third-party visualization and parameterization.

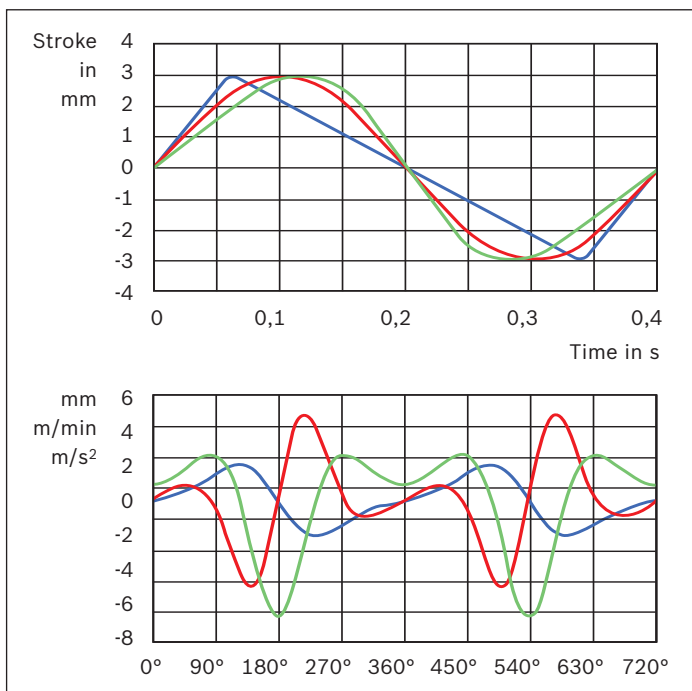

**Sinusoidal, asymmetric
sinusoidal or saw-tooth
oscillation.**

■ **Stroke height**
■ **Mold speed**
■ **Acceleration**

Individual Simulation: Developing Automation in Line with Practical Needs

The closer simulation is to reality, the better is the final result. In the development of a new continuous casting machine, the individual functions must always meet the individual requirements. With simulation techniques, which have proven in many large-scale projects, we can exactly simulate the functional properties of your plant, test them and develop extremely effectively thought-out drives.

Especially for mold oscillation, the perfect dimensioning and optimization of closed-loop controlled drives requires a high level of experience and profound knowledge across a wide range of technologies. The experience gained by the automation specialists of Rexroth over decades has been implemented in our simulation programs. This helps us to realize the complex connection of hydraulics, electronics, control and sensor technology and, in the end, find highly functional drive solutions.

Development software from specialists

Especially for mold oscillation, the simulation software solutions HYVOS, MOSIHS or D&C System Simulator, for example, allow a representation of the plant and its individual parameters very close to reality. The hydraulic system is simulated as early as at the engineering stage, and the function of the system can be tested and optimized. In this way, Rexroth software packages provide effective help in the development of practicable drives.

► **Simulation result**



Global Service: Competency Readily Available

In the metallurgical sector, downtimes are particularly expensive. Rexroth specialists are there whenever they are needed. And Rexroth also ensures fast availability of spare parts worldwide. At any time and over decades – just as you may expect it from a company of the Bosch Group.



◀ **Close to the customer:**
Be it for maintenance, repair, the worldwide supply of spare parts, modernizations or adjustments on site – Rexroth is always by your side in more than 80 countries!

Worldwide spare parts, local content

Rexroth has always seen itself not only as technology leader, but as system partner for the modernization of metallurgical plants with local presence in more than 80 countries and functions that have proven in practice and are based on application know-how gained over years and across continents.

Rexroth can therefore support operators and system integrators competently and locally with complete system solutions. From engineering through to commissioning of hydraulics and across the entire service life. Thanks to its international production network, Rexroth meets, of course, also the requirement of local content. The result becomes apparent in everyday production: Shorter conversion phases, reduced causes of failure and increased productivity.

One Partner Worldwide

Electrohydraulic systems from Rexroth have proven in metallurgical plants all over the world for decades. In complete new and in specific modernizations alike. Rexroth specialists support operators and system integrators as partner over the entire lifecycle of the plant.



Bosch Rexroth AG

Zum Eisengießer 1
97816 Lohr, Germany
www.boschrexroth.com

Find your local contact person here:

www.boschrexroth.com/contact

The data specified above only serve to describe the product. As our products are constantly being further developed, no statements concerning a certain condition or suitability for a certain application can be derived from our information. The information given does not release the user from the obligation of own judgment and verification. It must be remembered that our products are subject to a natural process of wear and aging.