

Fluid Forming – Hydroforming with Rexroth



Maximum Precision with Single-Component Forming



Fluid Force

Forming processes, where complex single-component workpieces are pressed into shape with the help of fluid pressure, have really established themselves as an efficient alternative to forming undertaken by conventional press tools.

Marked by a responsible use of resources in keeping with the times, by means of continuous process development increasingly more is being created from less material than ever before.



As worldwide innovation, technology and market leader Rexroth works internationally not only with users, but also with the Research Institute for Forming Technology at the University of Stuttgart, on the continuing development of this forward-looking technology. By linking powerful hydraulic precision components with optimally designed and matched open and closed loop control technology to form highly efficient high-end solutions, Rexroth systems are also achieving results in this field that are setting standards the world over.

For high-pressure hydraulics there are enormous demands on the static and dynamic drives – extreme forces act on the system and its components. This requires a sensitive use in all aspects of safety, which Rexroth always fulfills over and above the norm. All components and systems undergo various stringent test and quality assurance procedures.

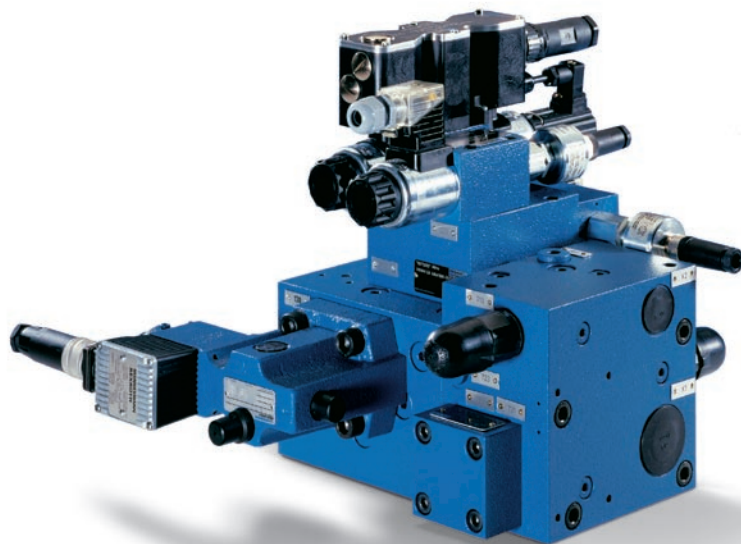

High-Pressure Forming	4
Hydraulic Clamping Device	6
Hydromechanical Clamping Device	8
High-Pressure Components	
Pressure Intensifier	10
Valve Technology Transducer	11
Axial Cylinder Open Loop Control MAC8	12
Open Loop Control HNC100-3X Clamping Cylinder Control Valve Technology Pump Control System Drive Power Units	14

Forming with Fluid Power: High-Pressure Forming

High-pressure forming opens up the possibility of producing components that are smaller and lighter than comparable molded parts, and that also offer better utilization of materials and greater stability.

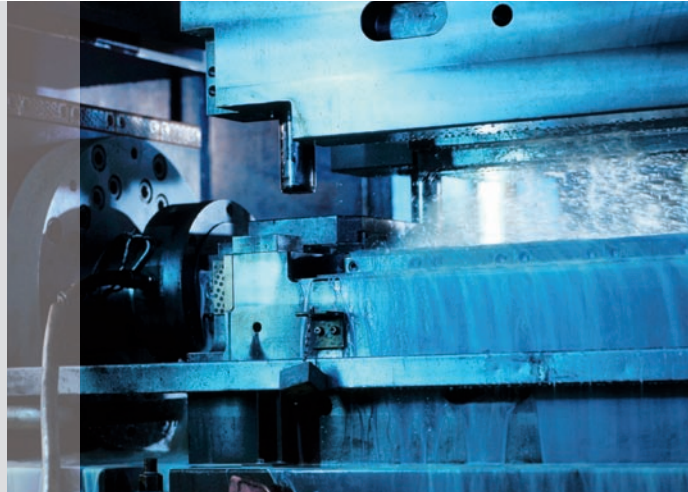

In the automotive industry we cannot imagine life without this method of hydroforming in the area of chassis, engine and driving gear components. However, other sectors are also increasingly taking advantage of the benefits of this technology: high-pressure forming is used, for example, in the manufacture of drums and sud containers for washing machines and tumble dryers.

We differentiate basically between two methods of high-pressure forming: internal high-pressure forming and hydromechanical deep-drawing.

Internal high-pressure forming – Forming of sealed hollow bodies

With internal high-pressure forming the tool consists of an upper and a lower part. Once the tool is clamped, hydraulic pressure acts on the internal surface of the workpiece, which then expands and is pressed into the contour of the tool.



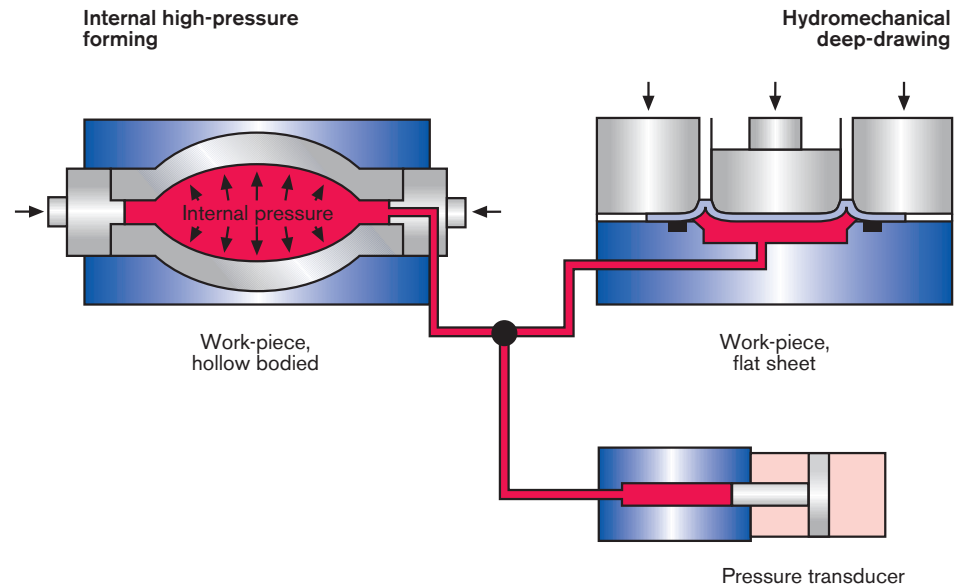

Hydromechanical Deep-Drawing – Forming of Flat Sheets

Alongside internal high-pressure forming, hydromechanical deep-drawing is also continually gaining in significance. With this process components can be manufactured in a single step, as opposed to conventional deep-drawing, which either requires several steps or, due to the extreme drawing conditions, would not be possible at all from a single component. Typical components from the automotive industry suitable for hydromechanical deep-drawing are extremely deep, contoured parts, such as tank shells, for example, as well as parts with a larger surface area such as car roofs and engine hoods.

Another considerable advantage of this process is the high surface quality of the manufactured parts. Unlike with conventional deep-drawing and internal high-pressure forming the tool here consists of only one half. The function of the other half is assumed by the medium under hydraulic pressure.

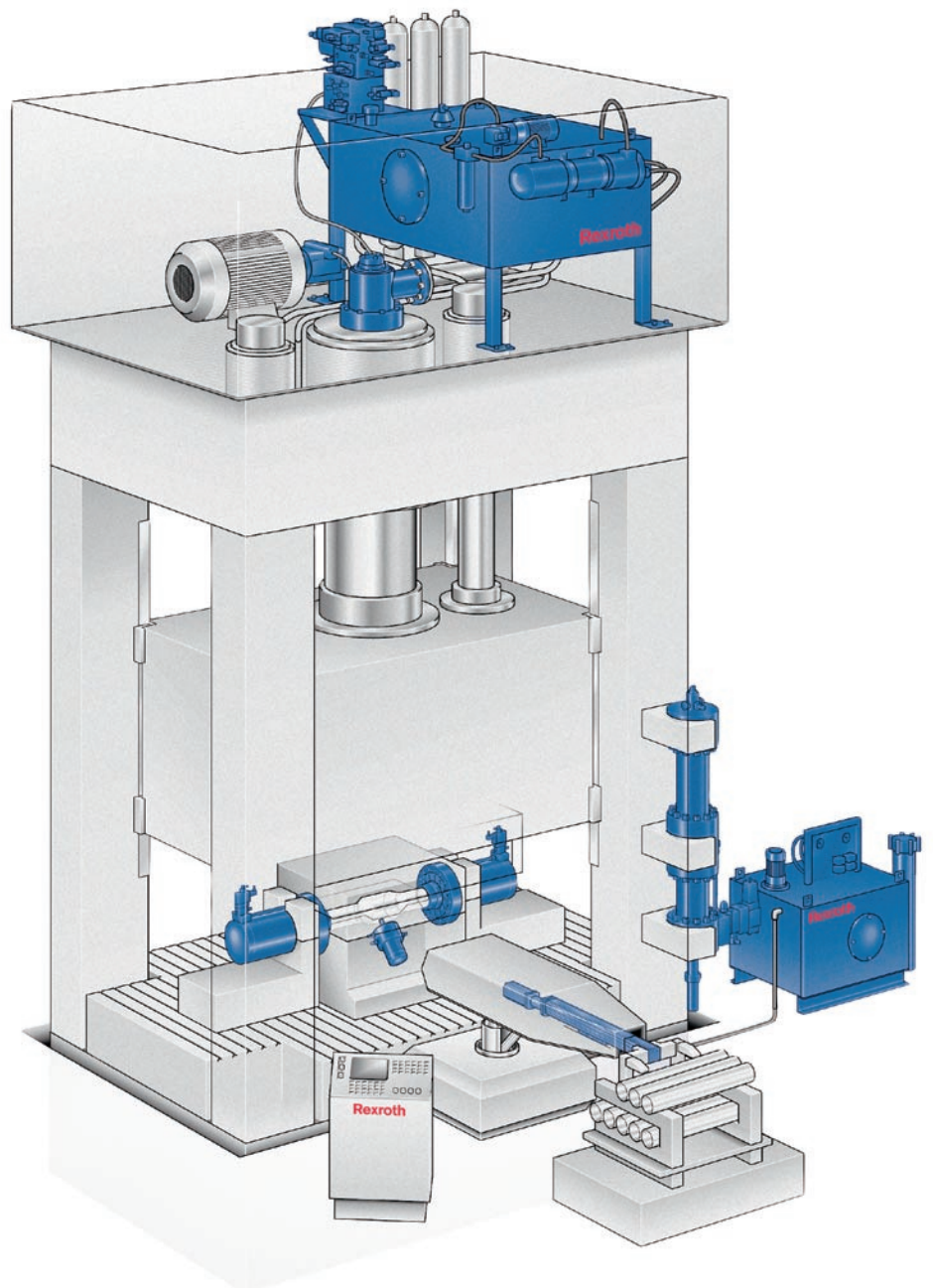

Causes and Effect: The Hydraulic Clamping Device

With both internal high-pressure forming and hydromechanical deep-drawing, a very high pressure is generated inside the tool. The expansion forces generated over the projected work-piece surface

act in the opening directions of the tool. For this reason suitable devices have to be available to keep the tool closed during the forming operation.

Standardized press module with built-on proportional valve technology

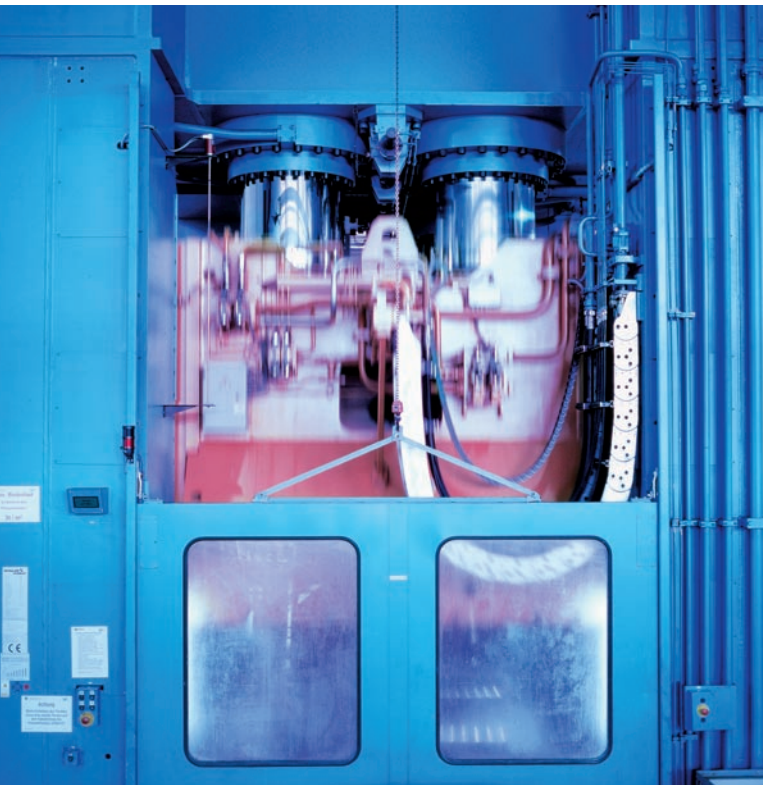
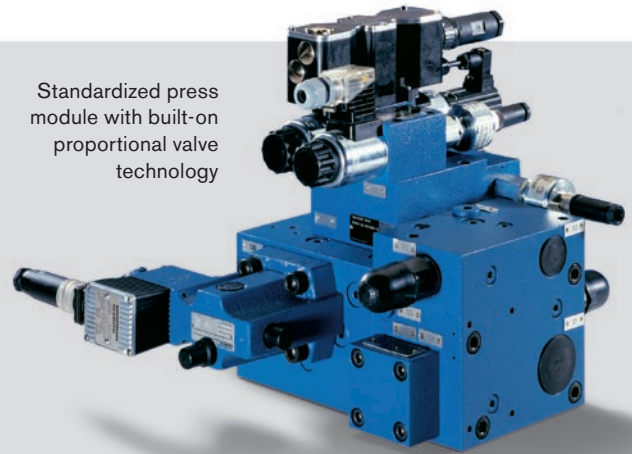

Such devices will be either hydraulic or hydromechanical clamping devices. The hydraulic one is able to generate the necessary clamping force over the complete stroke. In principle it corresponds to a simple conventional hydraulic press.

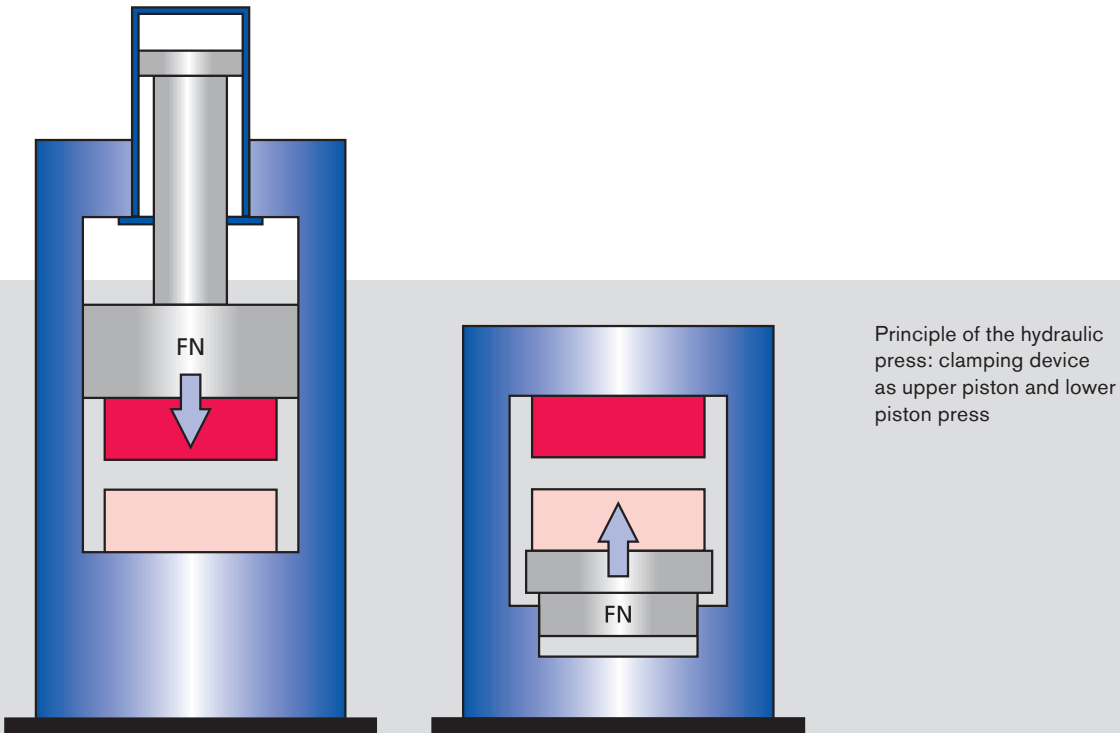

Principle of the hydraulic press: clamping device as upper piston and lower piston press

Rexroth – Guarantee of Operational Safety

Safety is one of the most important criteria in hydraulic press control systems – Rexroth is continuously setting new standards in its development: every press control – whether of smaller or larger size – complies with the safety regulations of the employer's liability insurance association, as well as fulfilling the stringent criteria of DIN EN 693. The safety regulations stipulated herein are applicable not only in the European partner countries; they are recognized worldwide and often used as a base.

Rexroth realizes compact open loop control systems containing extensive safety functions including:

- Main pump safety feature and pressureless bypass
- Proportional press force setting
- Redundant direction control with double safety feature against sinking and rising pressure of the compression piston, optional speed, pressure or position control
- Compression cylinder can be additionally switched on and off
- Fast advance in free fall
- Regenerative circuit
- Fast advance up/down with rapid traverse cylinder
- Set-up in free fall

The Plus for Force Clamping: The Hydromechanical Clamping Device

The hydromechanical clamping device can be distinguished from a purely hydraulic one by its additional mechanical locking device, the purpose of which is to withstand the forces generated during the forming process.

The actual compression stroke of the clamping device is relatively short and is used to pre-form the work-piece and close the two halves of the tool.

Features of a press with hydromechanical clamp: the bending force covers the complete stroke, whereas the nominal clamping force is not applied until after the mechanical locking operation.



Hydromechanical clamping devices with 35,000 KN nominal clamping force – a test installation for development of new processing technologies. The hydraulic high and low-pressure control of this machine was developed in co-operation with the University of Stuttgart.

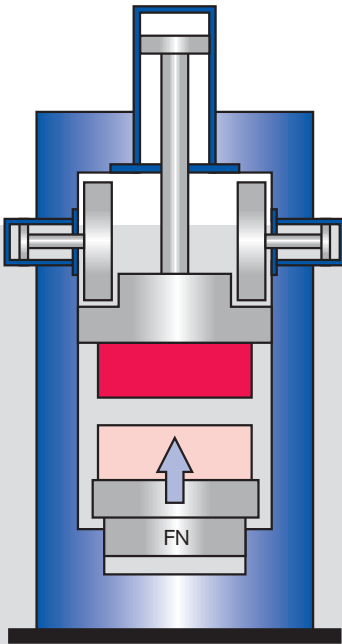

This customer-specific compact control system, consisting of three separate control blocks flanged together, is also designed to enable the blocks to be piped individually in the machine, thus positioning them as closely as possible to the cylinders.

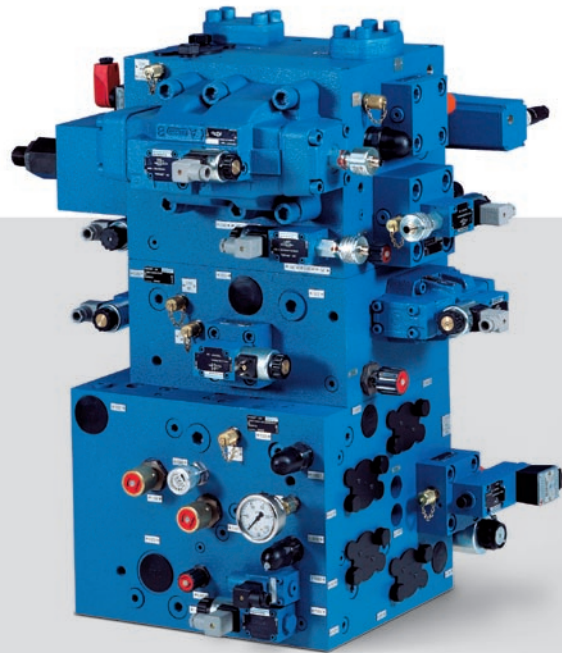

In its product program Rexroth also has standardized control systems for this type of press, for the compression stroke as well as for the mechanical locking. These have proven themselves already in thousands of applications in conventional presses and can easily be customized. It goes without saying that every control system mentioned here complies with the relevant safety regulations.

Swift movement through free fall

Both variants of retaining device can be integrated into the hydraulic directional control system, e.g. rapid traverse function by the press plunger for downwards movement in free fall. During this motion the press cylinder sucks in more oil from the tank, pre-fill valves being required for this.

These special valves operate at a high flow rate yet with an extremely low pressure differential. Rexroth components have been proving themselves particularly in this area for years now.



Sandwich plate pre-fill valve for inserting into cylinder base with built-on directional control valve

Quality Down to the Finest Detail: High-Pressure Components from Rexroth

Based on decades of extensive know-how and excellent development potential Rexroth has developed special high-pressure components for hydraulic systems to be used in high-pressure forming.



Pressure intensifiers

Pressure intensifiers from Rexroth have been setting standards in this sector for years. Through continuous, forward-looking development they fulfill the stringent requirements of high-pressure technology. The necessary media separation of mineral oil on the low-pressure side and HFA on the high-pressure side takes place inside the pressure intensifier by means of special technical specifications and specially developed sealing systems.

Pressure intensifiers are standardized and available with the following technical specifications:

- Type CHP2 for operating pressures up to 2,000 bar and 1.38 to 7.85 liters stroke volume
- Type CHP4 for operating pressures up to 4,000 bar and 1,38 to 7.85 liters stroke volume

- Pressures above 4,000 bar and other stroke volumes are also available on request.

With Rexroth pressure intensifiers the low-pressure side is the control side. A highly accurate flow rate of the high-pressure volume can be achieved with the aid of the integral digital SSI position measuring system, which can withstand pressures of up to 500 bar, combined with proportional valve technology on the low-pressure side.

High-pressure transducer for pressures up to 5,000 bar



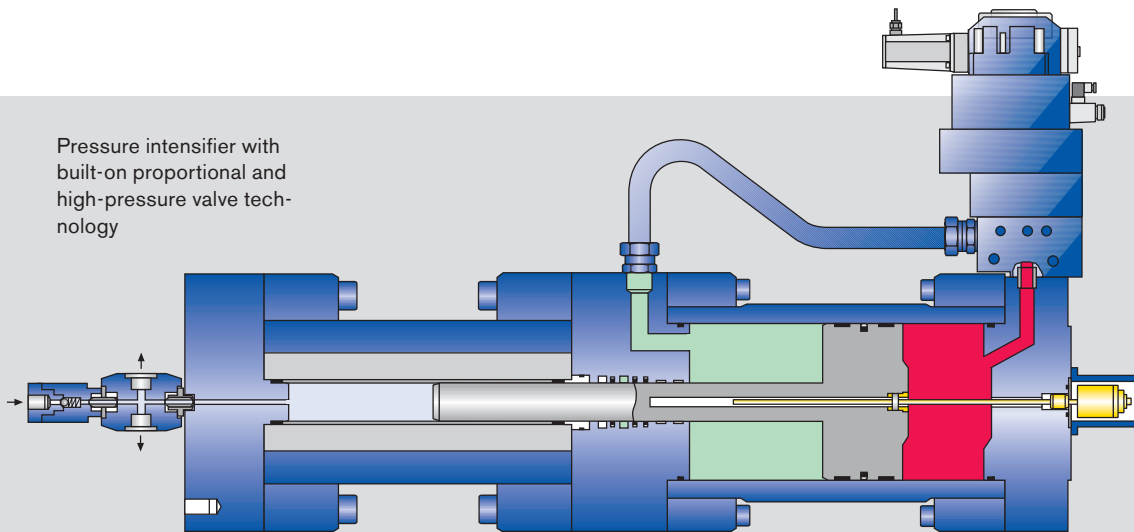

High-pressure valve technology

As the pressure intensifier on the high-pressure side cannot undertake the complete control operation, special high-pressure valves are used to steer the medium in the right direction. A distributor block and check valve are required to enable the pressure transducer to fill with HFA-fluid and then build up pressure. The large diameters of the Rexroth high-pressure valves are of particular benefit here, as they permit a high flow rate yet with low pressure loss. Time can be saved above all when filling of the pressure transducer.

High-pressure transducer

Special high-pressure transducers are used on the high-pressure side in order to give a basis for the high dynamic closed loop control of the pressure transducer. There are, however, special requirements here with respect to dynamic response and reproducibility of the pressure transducer: Rexroth high-pressure transducers are equipped with a special thin-film sensory mechanism, which meets these stringent requirements. The high stability of the sensors, combined with the seamless weld measurement cell, guarantee a high level of operational safety.



High-pressure distributor block and check valve for up to 4,000 bar maximum pressure

Quality Down to the Finest Detail: High-Pressure Components from Rexroth



Axial cylinders

These handle complex control tasks accurately and fast. These are practically series type special stacking cylinders – the valve control system is flanged directly on the cylinder and stacked vertically. To enable high response and traverse speeds to be attained, together with accurate positioning control, high dynamic response control valves, and in some cases, even servo valves, are used.



MAC8

The digital Rexroth multi-axis NC open loop control in modular design comprises a master card, which itself can control either two or four axes. If necessary it can be extended by up to four slave cards for four axes respectively. MAC8 thus offers the optimum solution for complex open loop control tasks with up to 20 axes which can be interpolated.

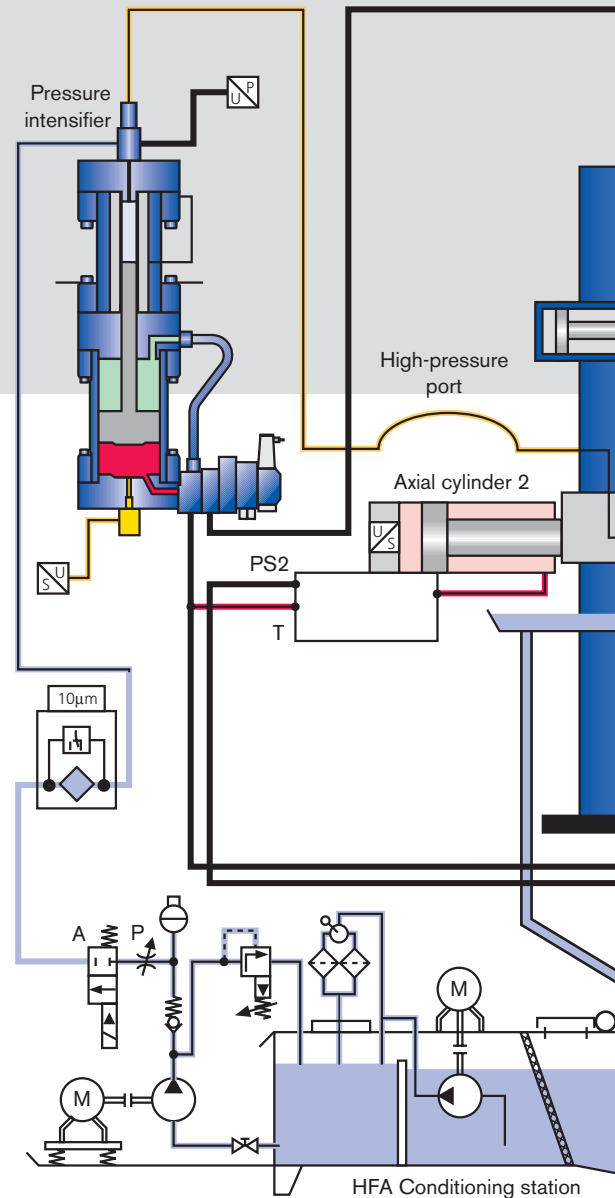

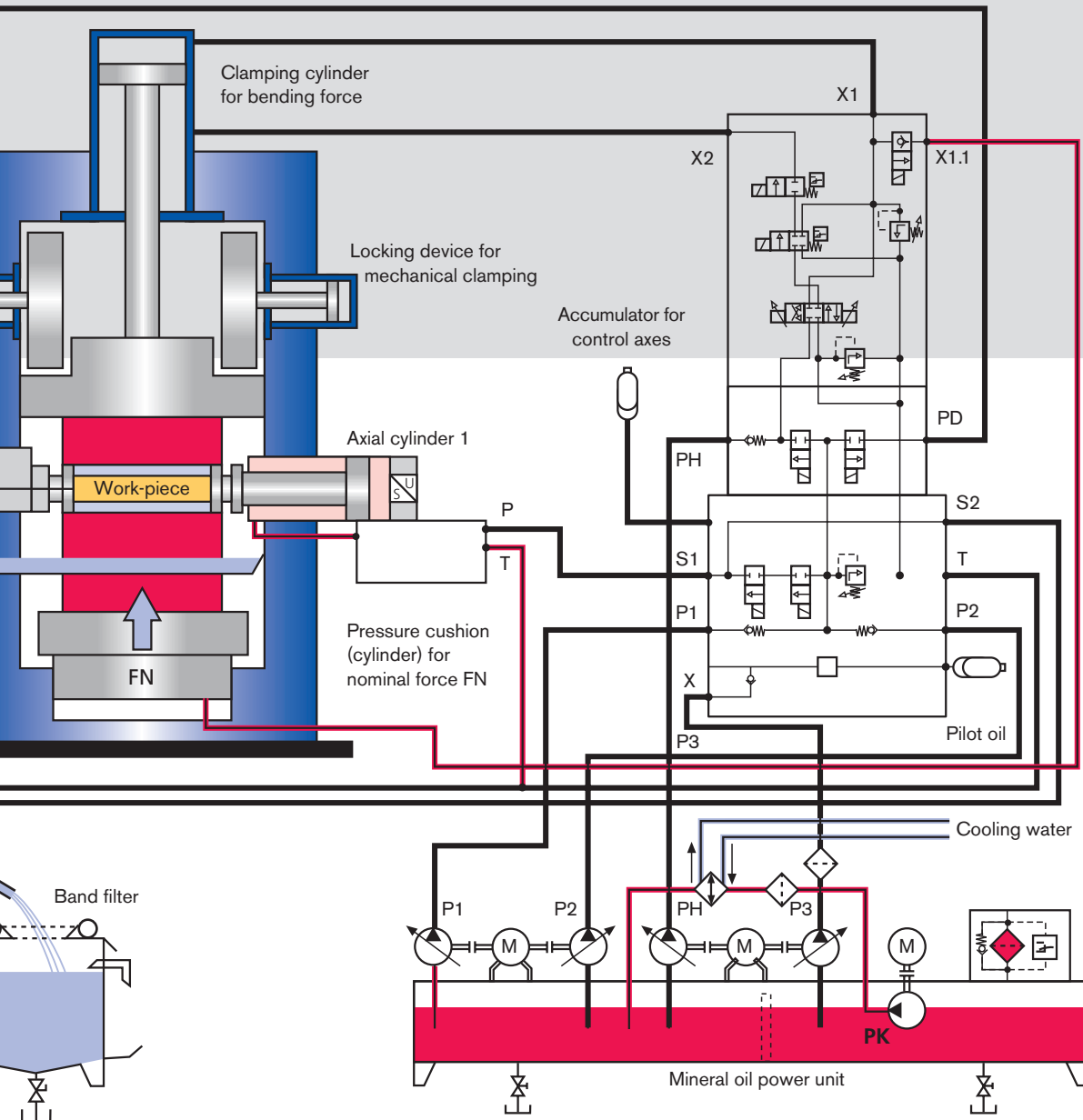



Further MAC 8 devices can be connected via local Ethernet. The MAC8 communicates via Fieldbus (Profibus DP or CAN) or via Ethernet with the superior PLC machine control. It possesses special hydraulic closed loop control characteristics, can control the machine movements completely independently and thus also take on PLC functions. Sensors and actuators can be evaluated or controlled as relevant by means of CAN-Bus.

HNC 100-3X

This scalable digital axis control is a freely-programmable, bus-compatible NC control for both electrohydraulic and electromechanical drives. It takes on sequential open and closed loop control of up to four drives, as well as communication with the superior PLC or PC control. Optimum behavior of electrohydraulic drives is achieved by means of open and closed loop control algorithms specially matched to the characteristics of the hydraulics.



Clamping cylinder

An extensive standard cylinder program is available, with different pressure ranges, piston diameters from 25 to 500 mm as well as stroke lengths of up to 10 m. Deviations from standard dimensions and pressures can be accommodated without problem.

Closed loop valve technology

The Rexroth range of proportional, control and servo valves leaves no stone unturned. Rexroth is worldwide leader in the development and manufacture of proportional and control valve technology, in particular for the high-pressure forming process.

Pump control system SYHDFEE

For closed loop control of pressure and flow and thus optimum matching to the needs of the user. There is also the option of power control. The system comprises the tried-and-tested swashplate axial piston pump Type A4VSO, a built-on proportional pilot valve and a swivel angle transducer.



The complete control function of the system is integrated into the closed loop control electronics of the pilot valve. Extremely short adjusting times and excellent control quality can be realized.

Drive power unit

The extensive standard program for smaller and medium-size hydraulic control systems is complemented by user-specific drive power units, matched exactly to every requirement. Special noise-damping whispering power units can also be used, as can power units designed for use with special fluids.



Intelligent Hydraulics in New Dimensions

Wherever forces need to be utilized economically, the advantages of industrial hydraulics are obvious – whether it is required to lift and lower loads smoothly, perform linear or rotary movements, achieve constant acceleration, maintain given speeds, approach positions exactly, transmit powers or interlink sequences.

Rexroth is the technology and market leader in industrial hydraulics with a comprehensive product range and distinct application expertise.

At Rexroth you can select from the worlds' largest standard product range in the field of hydraulics, application and customer-specific

system solutions of high quality. With advanced micro-electronics Rexroth has made hydraulics even more powerful.

For you, Rexroth is the ideal partner for developing highly efficient machines and production facilities – from the first point of contact to commissioning and throughout the entire life cycle. Teams that operate worldwide carry out the complete engineering of your systems and, if requested, up to the hand-over of turnkey systems and beyond – service included.

Thanks to the use of hydraulic drive and control technology from Rexroth you will be more competitive than ever.

The Drive & Control Company

Rexroth offers a unique and comprehensive range of products and services across technologies in its six fields of technology and service areas – strong in high-quality individual technologies, combined with highest application-specific competence in system packages with integrated complete solutions.

Industrial
Hydraulics

Electric
Drives and
Controls

Linear
Motion and
Assembly
Technologies

Pneumatics

Service
Automation

Mobile
Hydraulics



Rely on service across technologies

Rexroth integrates all services for the entire product spectrum in the field of factory and industrial automation into a single organization: from immediate support, spare parts service, field and repair service, retrofit/modernization through to training.

Bosch Rexroth AG
Industrial Hydraulics
Zum Eisengießer 1
97816 Lohr, Germany
Phone: +49(0)9352/18-0
Fax: +49(0)9352/18-1638
info.bri@boschrexroth.de
www.boschrexroth.com