

Ball Rail Tables Maintenance Manual

The Drive and Control Company

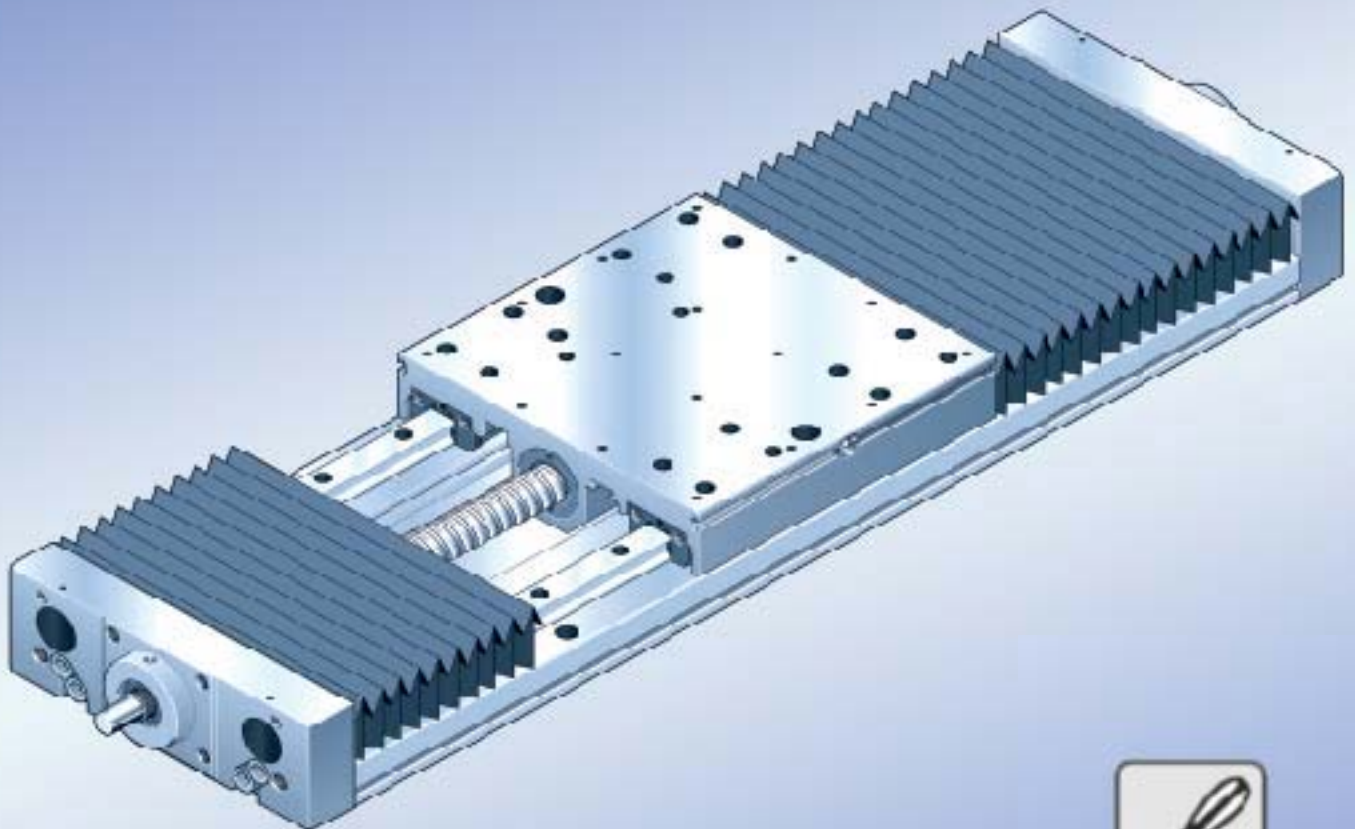

Mounting

1. Safety, Cross-References and Symbols	2
1.1 Safety notes and their symbols	2
1.2 Cross-referencing symbols	2
1.3 Symbols	2
2. Overview of Ball Rail Tables	3
2.1 Type Overview	3
2.2 Nameplate, Ordering of Spare Parts	3
2.3 Ordering of Components and Catalogs	3
3. Ball Rail Tables Fixings	4
3.1 Fixing the ball rail tables	4
3.2 Transport protection	4
4. Overview of accessories and attachments	5
5. Mounting the switching system	6
5.1 Mounting internal switches	6
5.2 Mounting external switches	6
5.3 Adjusting the switches	7
5.4 Mounting the socket	7
5.5 Mounting and dismantling the cable duct	8
6. Mounting the drive	9
6.1 Mounting the motor complete with motor mount and bellows coupling	9
6.2 Mounting the motor complete with motor mount and push-fit coupling	10
6.3 Dismantling a motor with motor mount	10
6.4 Mounting the motor with timing belt side drive	11
6.5 Dismantling the motor and timing belt side drive	12
7. Maintenance	13
8. Mounting assemblies and wear parts	14
8.1 Overview	14
8.2 Dismantling/mounting bellows	15
8.3 Replacing the fixed bearing	16
8.4 Replacing the floating bearing	17
8.5 Replacing the ball screw drive (BSD)	17
8.6 Replacing the sealing strip	17
8.7 Replacing the guide rail, carriage or base plate	17
9. Mounting X-Y tables	18
9.1 Mounting two ball rail tables of the same size (base plate on carriage)	19
9.2 Mounting a ball rail table of the next smaller size (base plate on carriage)	20
9.3 Mounting two ball rail tables of the same size (carriage to carriage)	20
9.4 Mounting a ball rail table of the next smaller size (carriage to carriage)	20

1. Safety, Cross-References and Symbols

1.1 Safety notes and their symbols

The following symbols are used to identify safety notes:



DANGER !
Risk of coming into contact with power-conducting parts! Cut off power supply!



WARNING!
Risk of injury!



Caution!
Risk of damage to Ball Rail Table or adjoining structures!



Caution!
Keep Ball Rail Table clean!
If necessary, cover it over!

1.2 Cross-referencing symbols

The symbols below are used to refer to repeat or follow-on work operations:

→ 5.4 See Section 5.4

→ 5.4.2 See Figure 5.4.2
(Figure 2 in Section 5.4)

Note, recommendation

1.3 Symbols



Screw friction factor 0.125
Strength class 8.8



Tightening Torque

2. Overview of Ball Rail Tables

2.1 Type Overview

Ball rail tables are available in four sizes and in some cases in different heights. For precise data and dimensions, please refer to the "Ball Rail Tables" Catalog.

In the present document, only the ball rail tables with ball screw drive (BSD) are illustrated.

! Bosch Rexroth Ball Rail Tables can be mounted and maintained by suitably trained technical personnel with the aid of this manual.

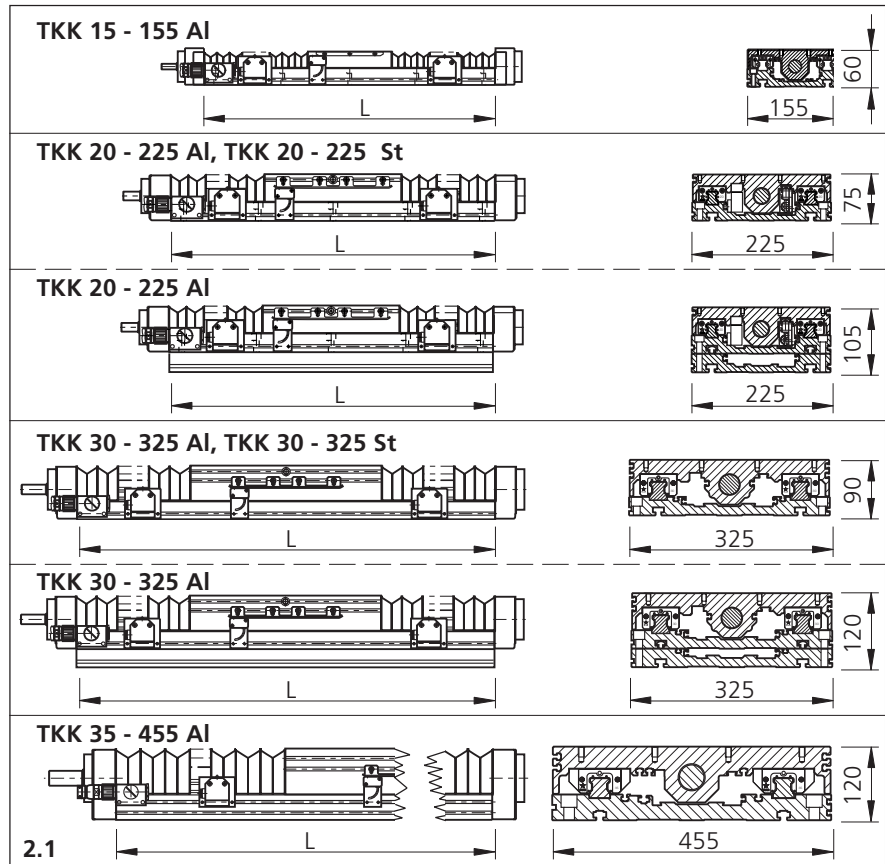

2.2 Nameplate, Ordering of Spare Parts

- 1 Part number of ball rail table
- 2 Serial number
- 3 Date of manufacture

- When ordering wear parts, please always quote all the information on the nameplate.

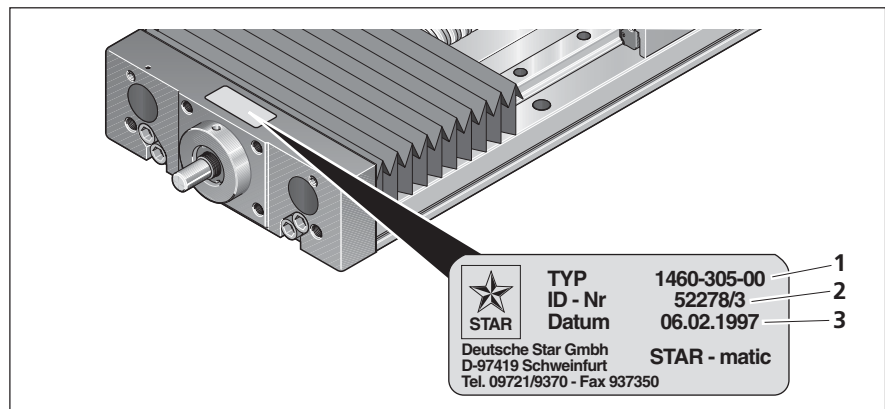

2.3 Ordering of Components and Catalogs

To order components, please refer to the Catalog for "Ball Rail Tables" or for "Controllers, Electrical Accessories".

- These Catalogs supplement the current instructions and should therefore be kept handy
- Please order the latest publications from your local Bosch Rexroth sales partner.





3. Ball Rail Tables Fixings

3.1 Fixing the ball rail tables

- 1 Plug
- 2 Base plate
- 3 Reference edge
- 4 T-nut

Ball rail tables made of profiled aluminum can be fixed either ... from above (→ 3.1.1) ... or from below (→ 3.1.2).

Steel ball rail tables can be fixed only from above (→ 3.1.3).

In both versions, a reference edge is built into the base plate to help align the unit. The mounting plugs are supplied with the unit.

The T-nuts are available as accessories.

All connection dimensions are specified in the "Ball Rail Tables" Catalog.

⚠ Please also note the special connection system for ball rail tables: this system permits the assemblies to move along several different axes.

Tightening torques for the fixing screws
for friction factor 0.125
strength class 8.8 ↓

Screw	M6	M8	M10	M16
Torque in Nm	9,5	23	46	195

3.2 Transport protection

⚠ Warning! Before starting up the drive, remove the protective transport packing.

Aluminium version, secured from above

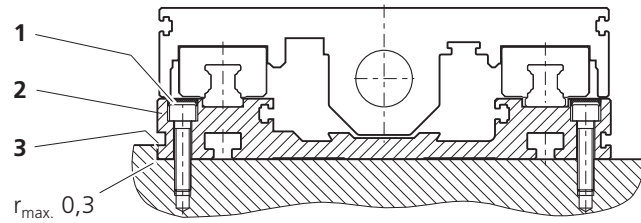

3.1.1

Aluminium version, secured from below

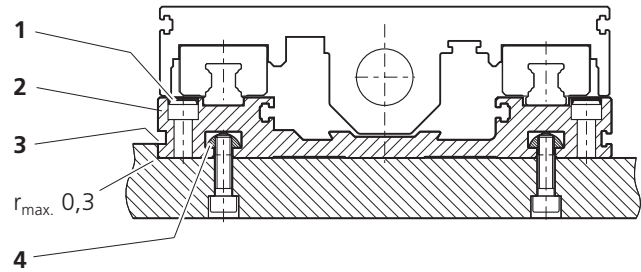

3.1.2

Steel version, secured from above

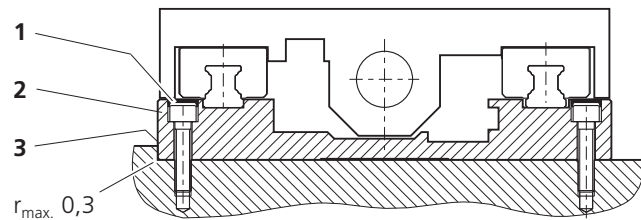

3.1.3

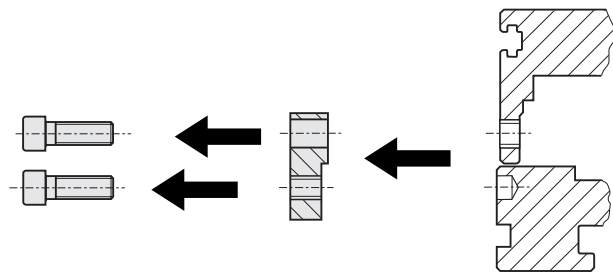

3.3



4. Overview of accessories and attachments

• If required, the following components can be mounted ready for operation. These Components may also be retro-fitted at any time.

Switching system

- 1 Mechanical switches, external
- 2 Cable duct
- 3 Switching cam
- 4 Proximity switch, external
- 5 Socket/plug for external switches
- 6 Profiled support
- 7 Socket/plug for internal switches
- 8 Mechanical and proximity switches, internal

➡ 5.

Drive

- 9 Motor mount and coupling
- 10 Motor
- 11 Timing belt side drive

➡ 6.

Mounting X-Y Units

Last chapter of this manual

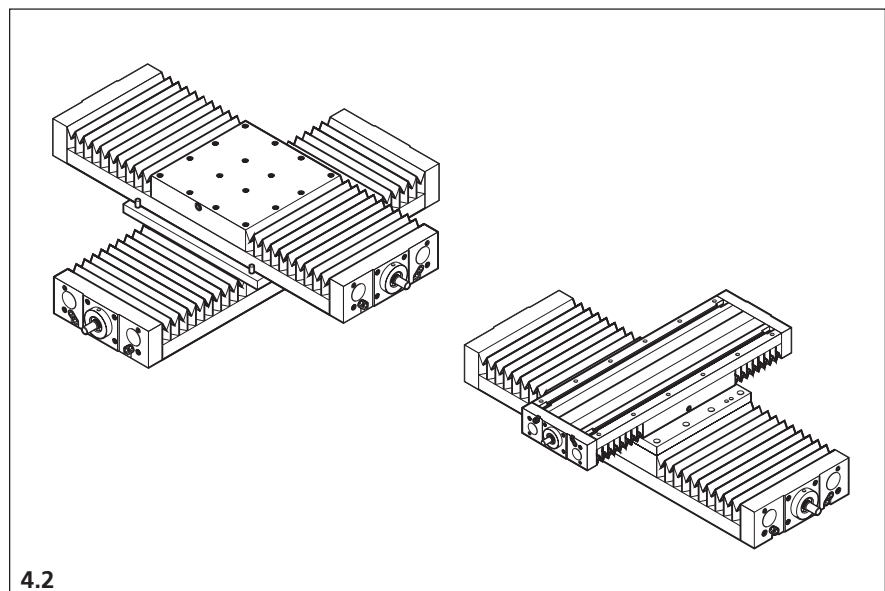
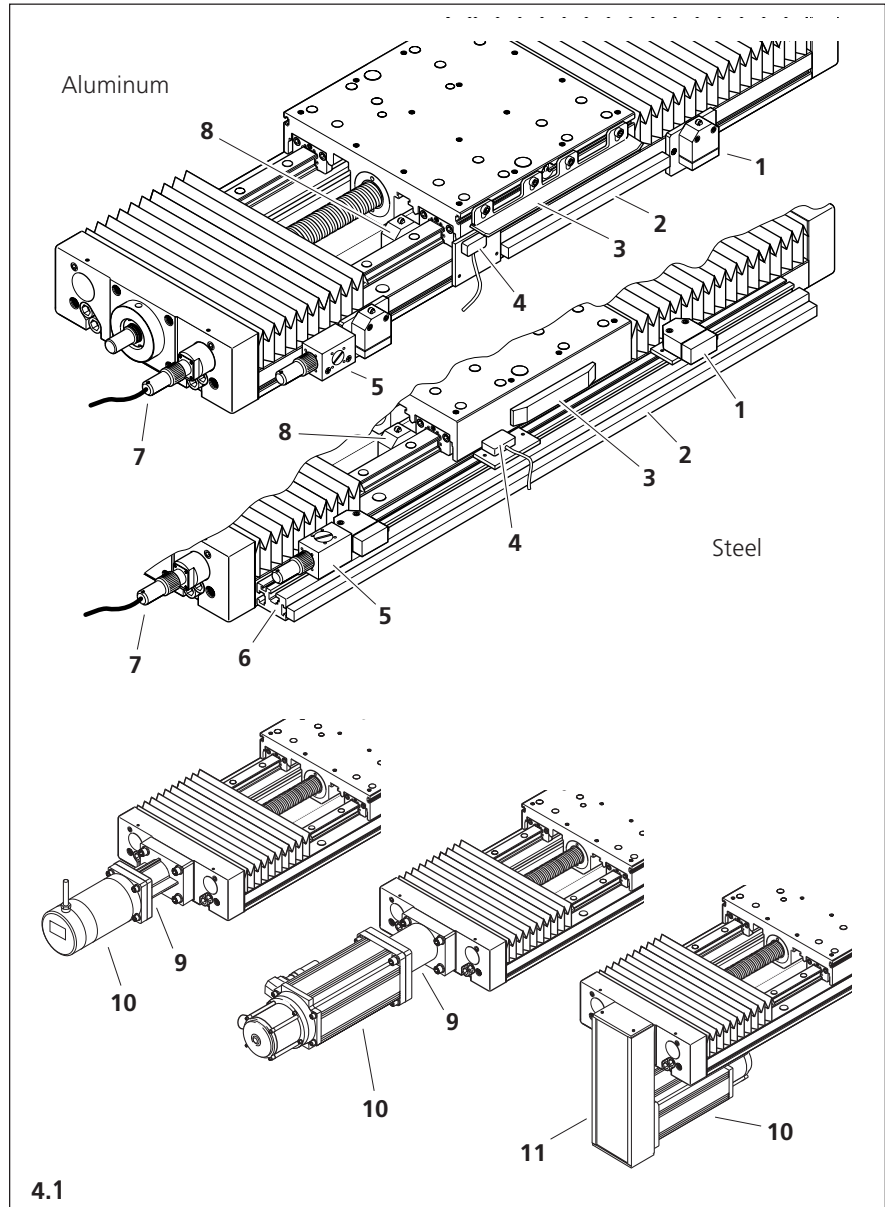



5. Mounting the switching system

5.1 Mounting internal switches

Aluminium version, mechanical switch (21)

- Solder the cable to the switch
- Screw the switch to the switch-plate
- Hook the switch-plate into position
- Lock the switch-plate in position with the set screw.

Aluminium version, proximity switch (22)

- Screw the switch to the spacer plate
- Screw the spacer plate to the switchplate
- Hook the switch-plate into position
- Lock the switch-plate in position with the set screw.
- To adjust the switch, slightly loosen the screw fixing between the spacer plate and switch plate and reset the switching distance and then retighten.

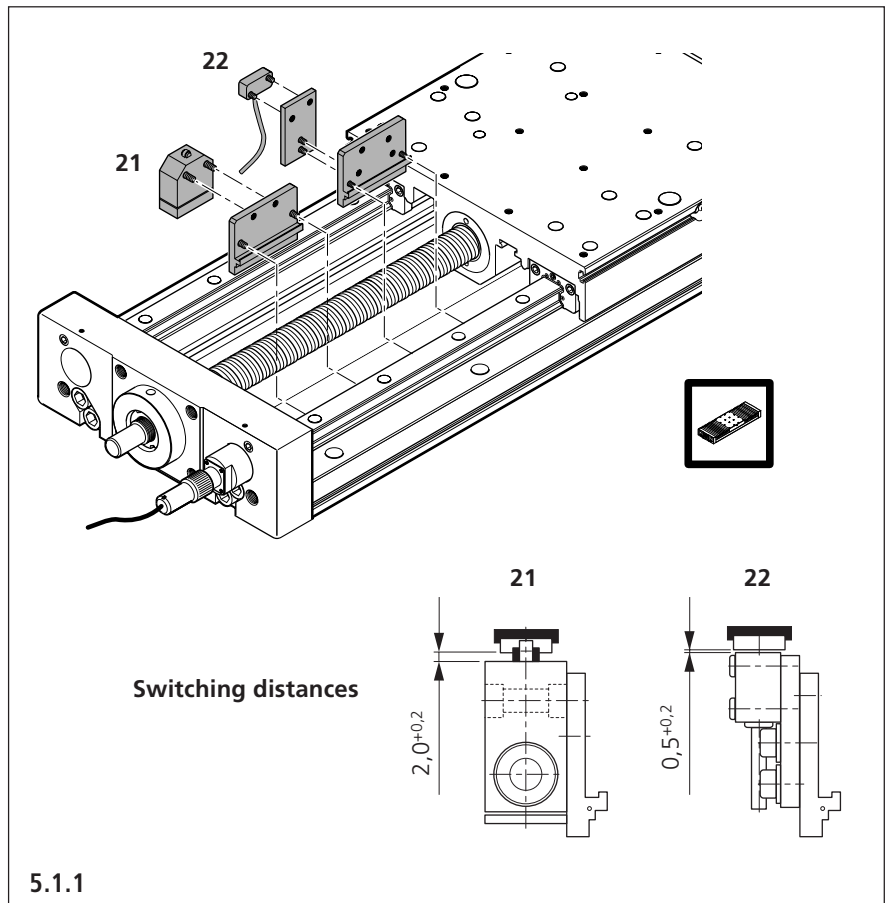

Steel version, mechanical switch (23)

- Solder the cable to the switch.
- Screw the switch to the switch-plate.
- Place the switch-plate on the base plate.
- Clamp the switch-plate in position with the set screw.

Steel version, proximity switch (24)

- Screw the switch to the spacer plate.
- Screw the spacer plate to the switchplate.
- Place the switch-plate on the base plate.
- Clamp the switch-plate in position with the set screw.
- To adjust the switch, slightly loosen the screw fixing between the spacer plate and switch plate and reset the switching distance and then retighten.

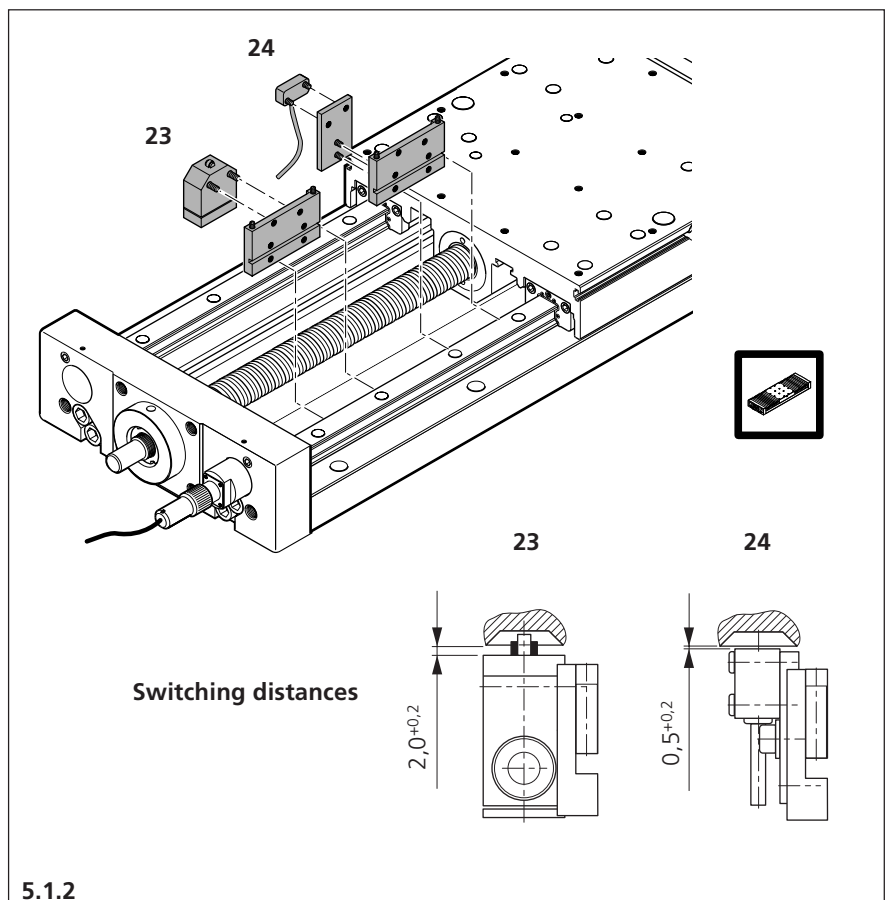



5.2 Mounting external switches

Aluminum version, mechanical switch (31)

- Connect the cable to the switch.
- Screw the switch to the switch-plate.
- Hook the switch-plate into position.
- Lock the switch-plate in position with the set screw.
- Adjust the switching distances by adjusting the switching cam.

Aluminum version, proximity switch (32)

- Screw the switch to the switch-plate.
- Hook the switch-plate into position.
- Lock the switch-plate in position with the set screw.
- Adjust the switching distances by adjusting the switching cam.

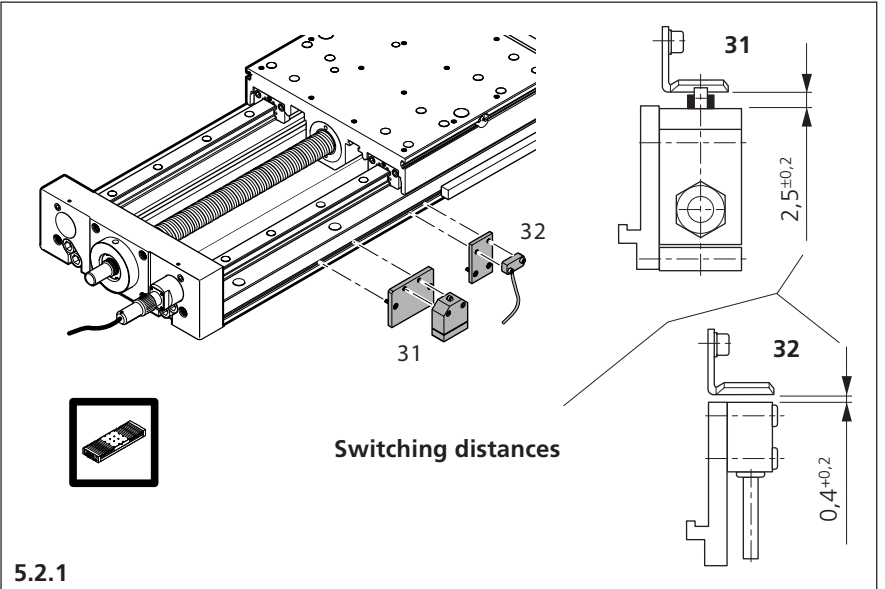

Steel version, mechanical switch (33)

- Connect the cable to the switch.
- Screw the switch to the switch-plate
- Fix the screw-plate to the profiled support with the T-nuts and screws.
- Set the switching distances by adjusting the switch.

Steel version, proximity switch (34)

- Screw the switch to the switch-plate.
- Fix the screw-plate to the profiled support with the T-nuts and screws.
- Set the switching distances by adjusting the switch.

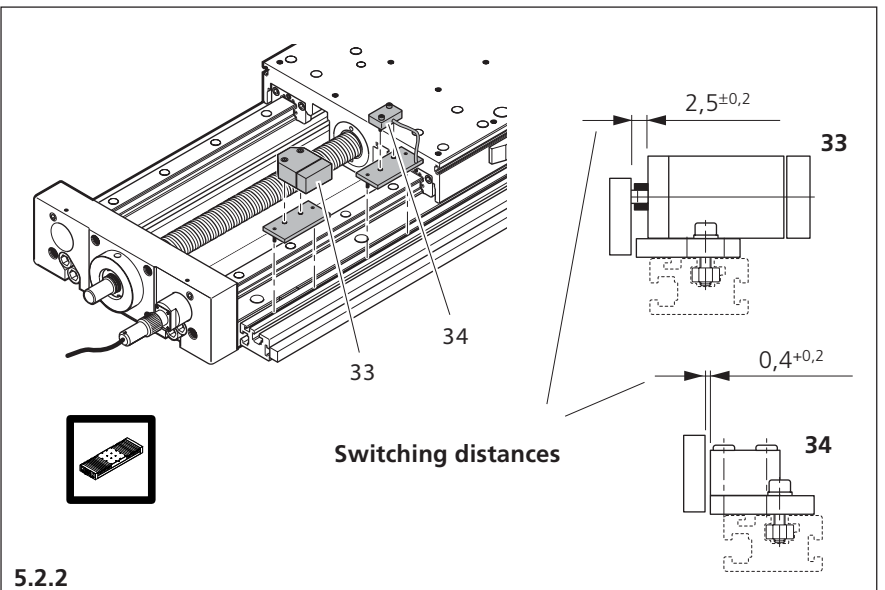

5.3 Adjusting the switches

When inner switches are shifted, the plastic sealing strip must be modified or replaced.

When outer switches are shifted, the cable duct must be modified or replaced. ➡ 5.5

The cable of proximity switches cannot be lengthened. The cables are molded into the switch. If a proximity switch with longer cable is required, we recommend that you buy a new switch.

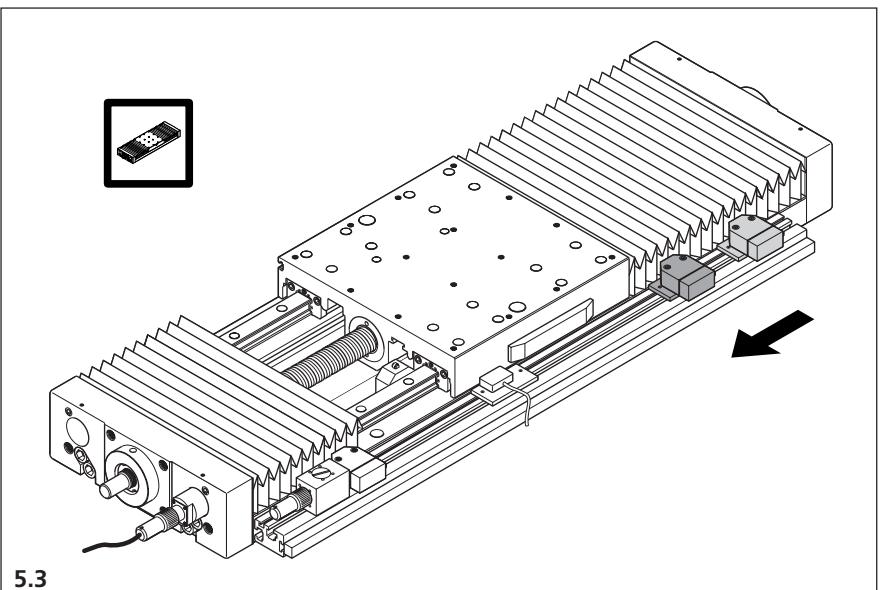



5.4 Mounting the socket

For internally mounted switches:

Internally mounted switches and sockets are supplied prewired. The delivery pack includes a plug with a pin layout diagram.

- Solder the cable to the plug in accordance with the pin layout diagram.
- Check that the circuit operates correctly.

To change internally mounted switches or sockets ➡ 5.4.2

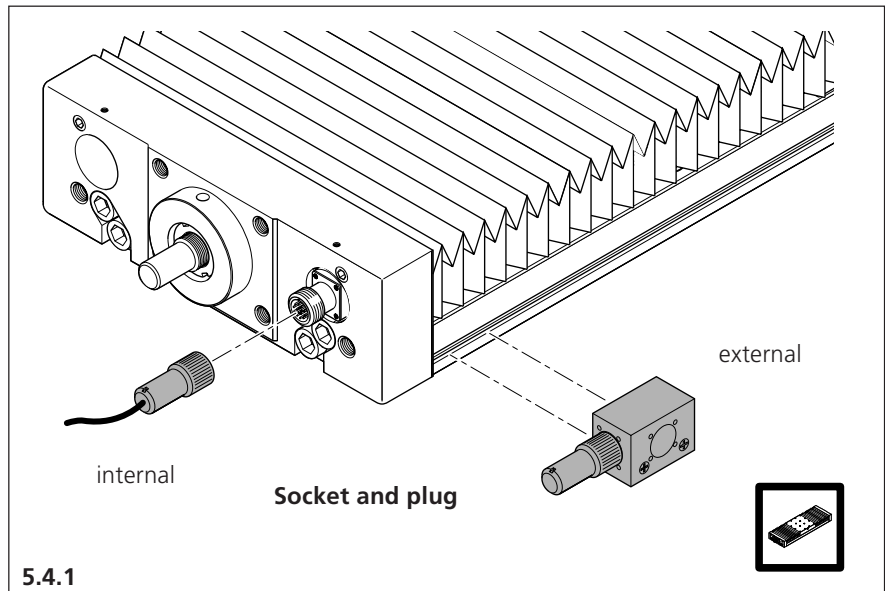

5.4.1

For externally mounted switches

➡ 5.4.3

External sockets are supplied in kit form for assembly. The pack includes two cable seals for fitting the cables in the socket.

One of these seals is ready-drilled with three holes designed for the cables of two mechanical switches and one proximity switch.

- If you have installed a different number of switches, make the appropriate cable holes in the undrilled cable seal.
- Thread all the cables through the clamping screw (1), cable seal (2), socket housing (3) and cork seal (4), taking care to use the appropriate plug connection orifice (5) for your installation.
- Seal the unused orifice (6) in the socket housing (3) with the O-ring (7) and blanking screw (8).
- Solder the cables in the flanged socket (9). Prepare the pin layout diagram. Screw the flanged socket (9) firmly into the socket housing (3) with the screws
- Press the cable seal (2) into the housing with the clamping screw (1).
- Hook the complete socket assembly on to the ball rail table and lock it into position with set screws.
- Mount the cable duct. ➡ 5.5
- Solder the cables in the plug.
- Check that the switch circuit functions correctly.

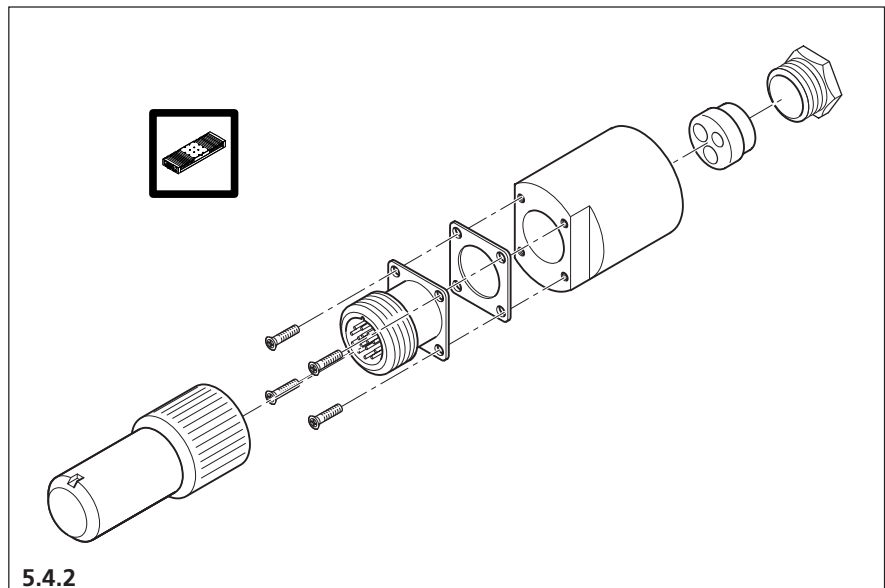

5.4.2

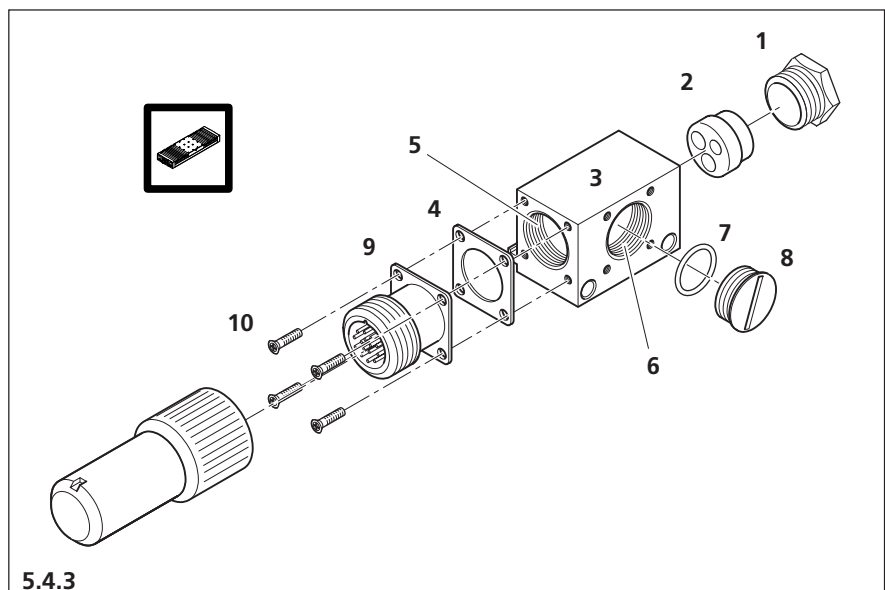

5.4.3



5.5 Mounting and dismantling the cable duct

The cable duct can hold a maximum of two cables for mechanical switches and three cables for proximity switches.

Mounting the cable duct

- Measure the length of cable duct required.
- Cut the cable duct to the required length and deburr.
- Measure, punch-mark and drill the cable outlet holes.
- If the existing fixing holes are not sufficient, drill additional fixing holes in the base of the cable duct (\varnothing 3.1, depth 2.5).
- Clip the cable duct into the groove on the ball rail table and screw firmly into place. The 8 mm long M3 screws are supplied with the duct. If required, 8 mm long M3 set screws increase the free space inside the cable duct.
- Cut the cable grommets to the appropriate cable diameter and install.
- Five cable grommets Ref. 8624-024-02 are supplied.
- Insert the cables and connect as required.

Mounting the duct cover without end-closure

- Measure the length of the cable duct cover; cut to length and deburr.
- Clip the cover into place.

Mounting the duct cover with end-closure

- Measure out the length of the cable duct cover.
- Allow an extra 18 mm for each duct end-closure.
- Cut the cover to length and deburr.
- Remove ridges from the bending area and from the end.
- Bend the cover and clip into place.

Dismantling the cable duct

- Lever open the end of the duct cover with a screwdriver.
- Lift the cover and turn it out of the duct.
- Remove the cables.
- Unscrew the fixing screws.
- Lever the cable duct out of the groove in the ball rail table with a screwdriver.

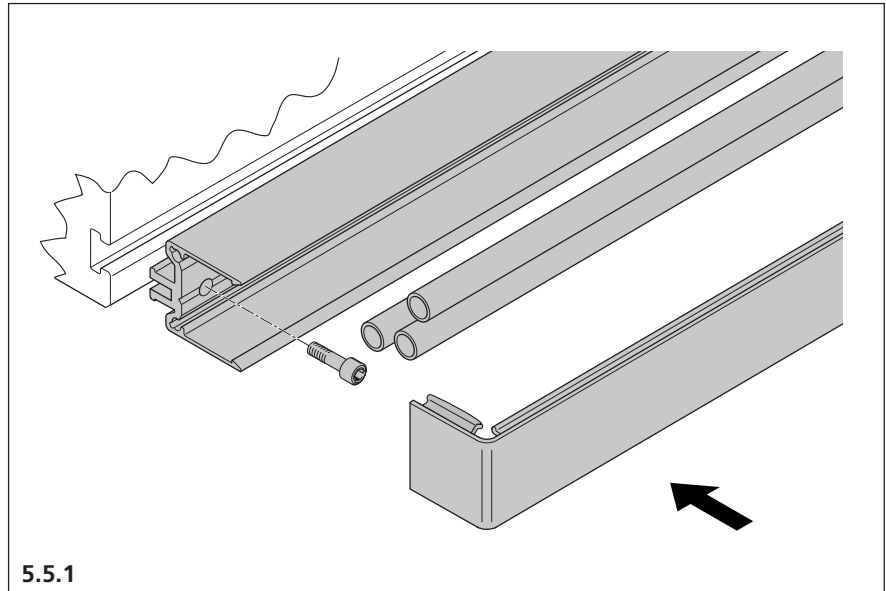

5.5.1

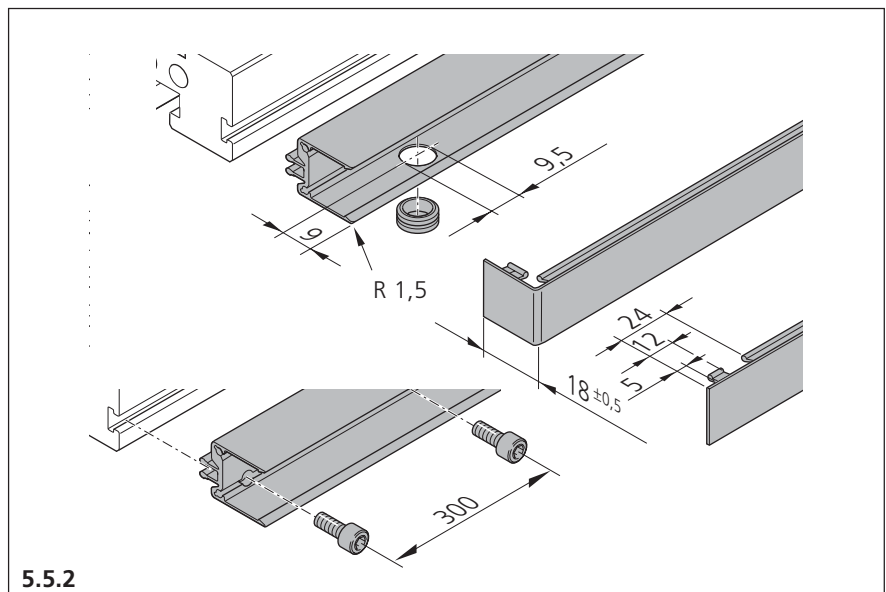

5.5.2

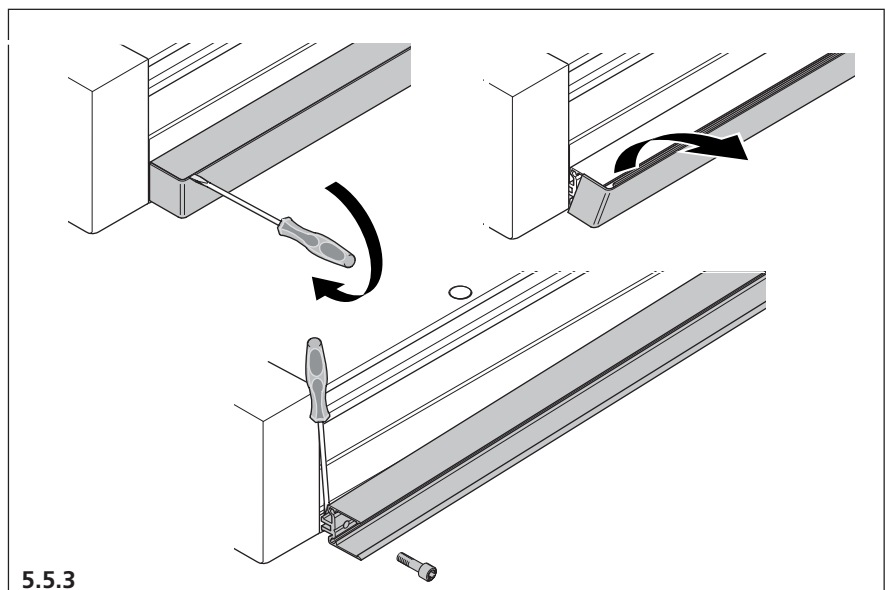

5.5.3



6. Mounting the drive

6.1 Mounting the motor complete with motor mount and bellows coupling

⚠ The maximum torque and maximum speed of the motor must not exceed the limits of the ball rail table!

- Screw the motor mount to the ball rail table. Tightening torques \Rightarrow 6.1.2
- Insert the coupling.
- Tighten the fixing screws of the coupling at the end next to the ball rail table. Tightening torques \Rightarrow 6.1.3
- If necessary, to tighten the second screw, turn the BSD 180° or move the carriage so that the BSD turns.
- Place the motor in the centering bore of the motor mount and coupling and secure firmly with four screws. Tightening torques \Rightarrow 6.1.2
- Tighten the fixing screws of the coupling at the end next to the motor. Tightening torques \Rightarrow 6.1.3
- If necessary, to tighten the second screw, release the motor brake, turn the BSD 180° or move the carriage so that the BSD turns.

⚠ Before using for the first time, check the EMERGENCY STOP switch!

Run through the first operating cycles at reduced speed in order to test the operation of the limit switches and the interaction of mechanical and electronic systems.

6.2 Mounting the motor complete with motor mount and push-fit coupling

⚠ The maximum torque and maximum speed of the motor must not exceed the limits of the ball rail table!

- Fit one half of the coupling to the drive journal of the ball rail table and the other half to the drive journal of the motor.
- Set distances A and B.
- Tighten the screws of the coupling halves with the tightening torque specified in Table.
- Fit the gear ring to one of the mounted coupling halves.

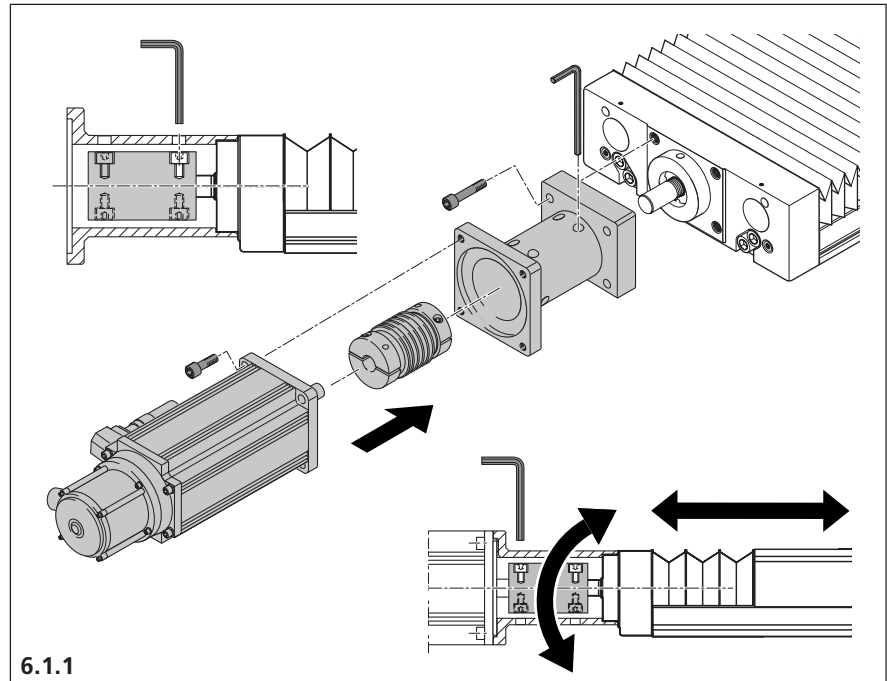

6.1.1

	M5	M6	M8	M10
\varnothing (Nm)	5,5	9,5	23	46

6.1.2

	M5	M6	M8
\varnothing (Nm)	8	13	30

6.1.3

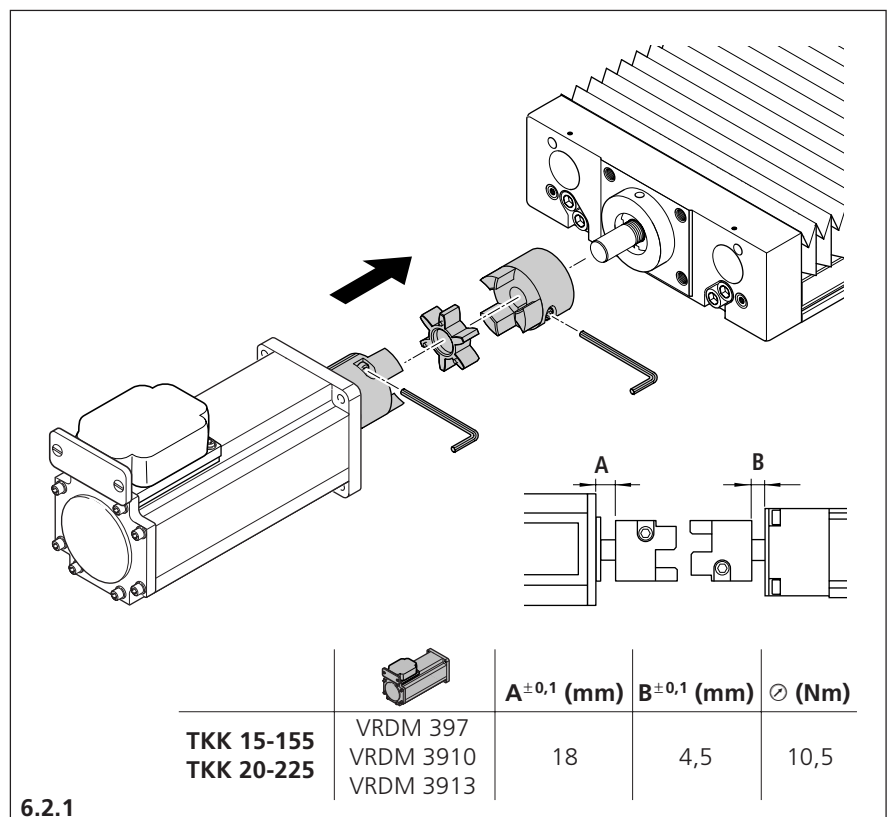

6.2.1

		A $\pm 0,1$ (mm)	B $\pm 0,1$ (mm)	\varnothing (Nm)
TKK 15-155	VRDM 397	18	4,5	10,5
TKK 20-225	VRDM 3910			
	VRDM 3913			



Mounting the motor complete with motor mount and push-fit coupling (continuation)

- Place the motor mount in the locating recess of the ball rail table and screw firmly into place.

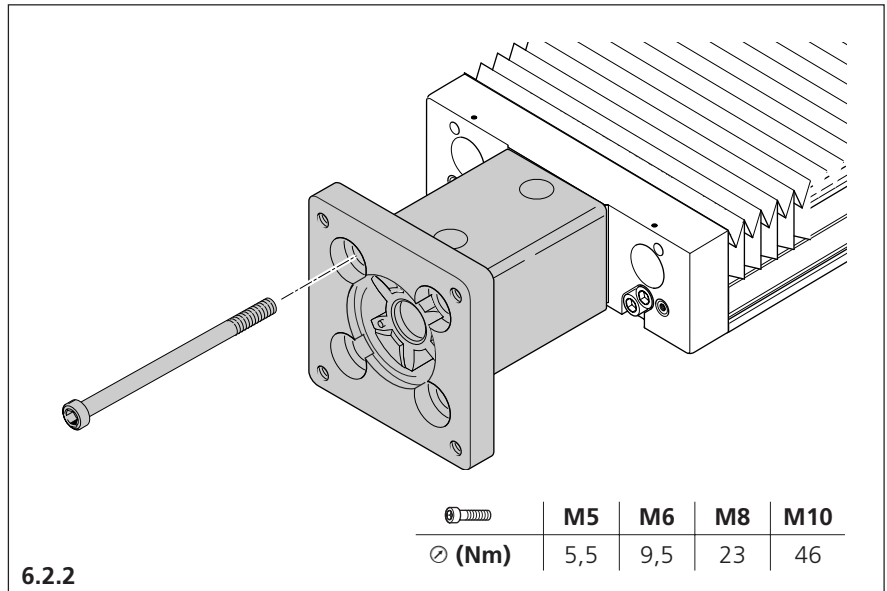

6.2.2

- Align the motor so that the two coupling halves fit into each other, and press the coupling strongly together so that the two halves join.
- Align the motor with the centring bore of the motor mount and insert it into the centring recess. Screw firmly into place.



Before using for the first time, check the EMERGENCY STOP switch!

Run through the first operating cycles at reduced speed in order to test the operation of the limit switches and the interaction of mechanical and electronic systems.

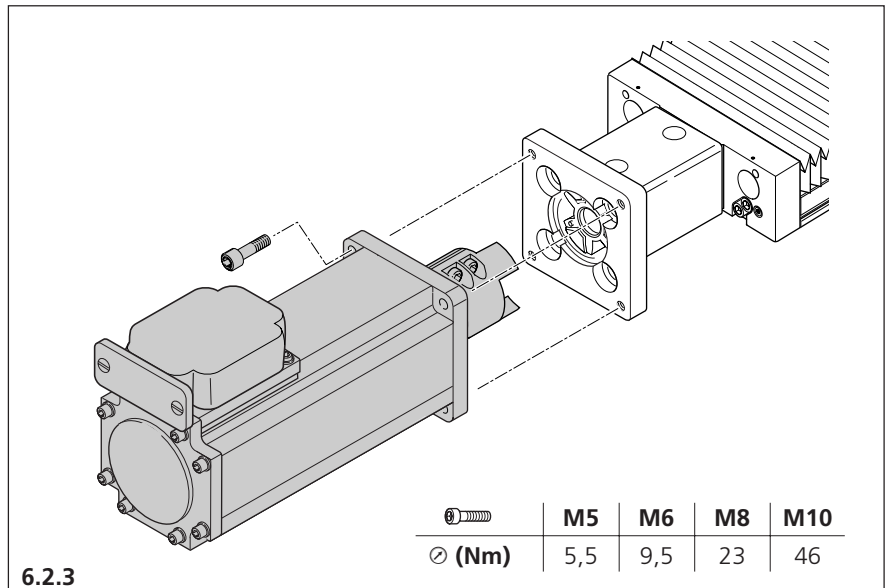

6.2.3

6.3 Dismantling a motor with motor mount



If the ball rail table is mounted vertically or at an inclined angle, the carriage must be prevented from crashing down!



Disconnect from mains!

- For the version with bellows coupling only: loosen the fixing screws of the bellows coupling at the end next to the motor.
- Unscrew the motor from the motor mount and remove.

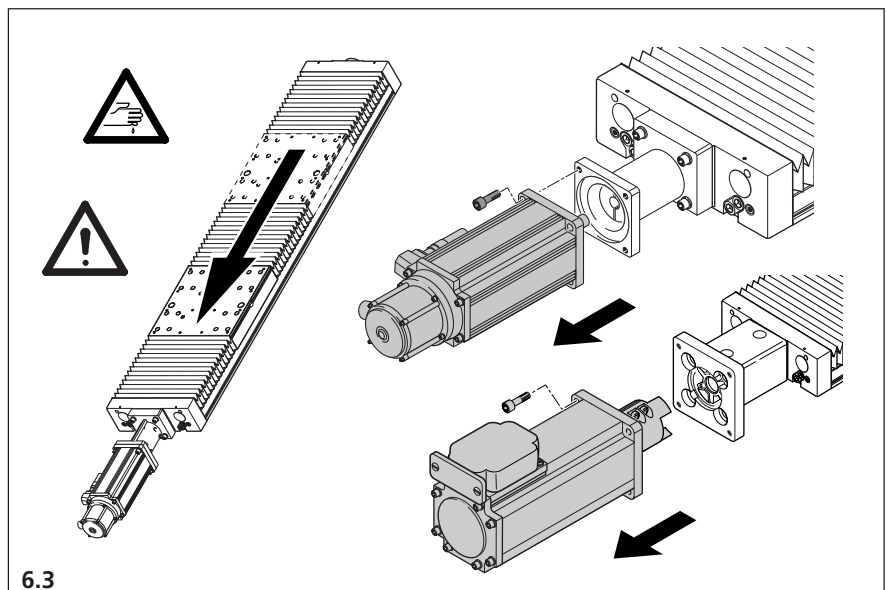

6.3



6.4 Mounting the motor with timing belt side drive

⚠ The maximum torque and maximum speed of the motor must not exceed the limits of the ball rail table!

Mounting the housing

- Screw the housing of the timing belt side drive to the ball rail table. Tightening torques ↓

Screw	M6	M8	M10
Torque in Nm	9.5	23	46

Mounting the first belt pulley

- Fit the belt pulley, complete with retaining ring, mounted timing belt and clamping assembly on to the journal of the ball rail table.
- Set clearance A from the housing.

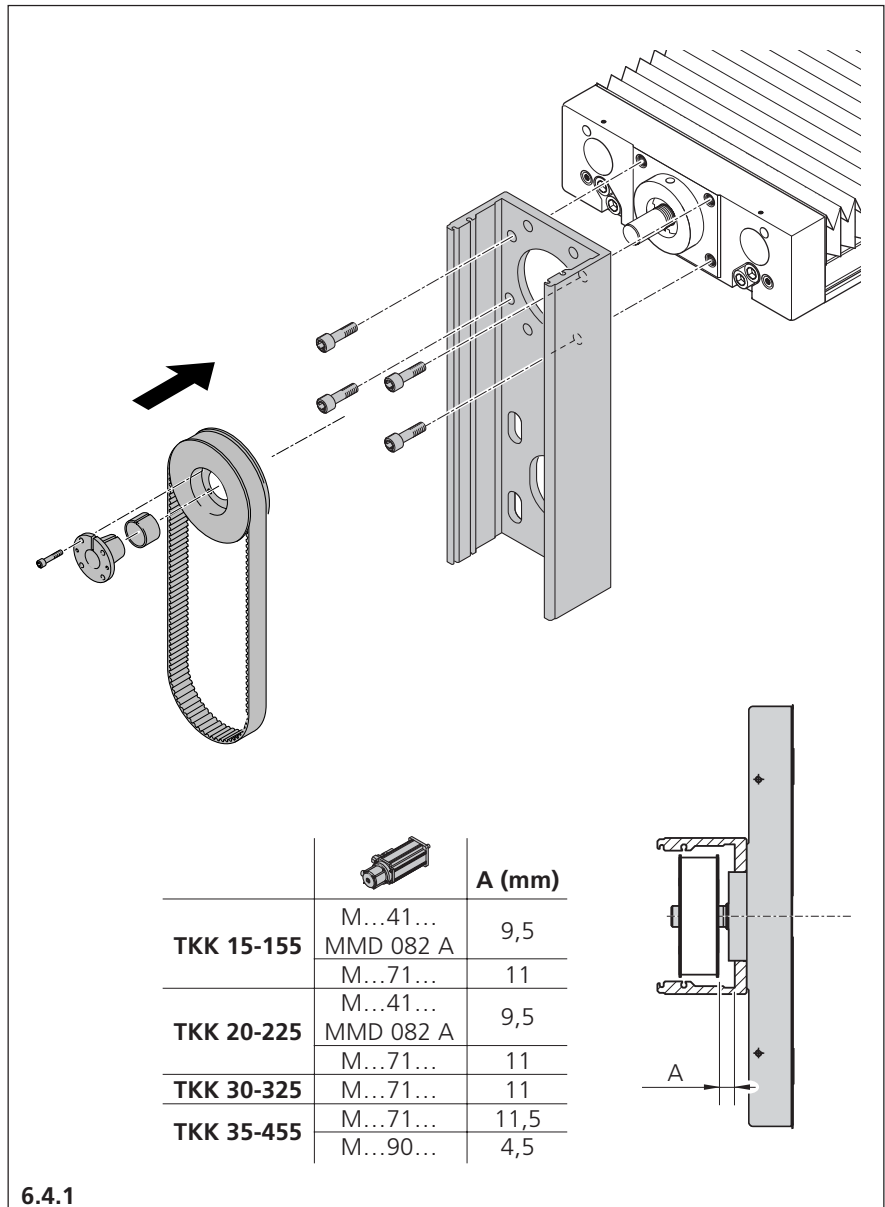

6.4.1

Mounting clamping assembly Type 1

Slightly oil the clamping elements.

⚠ Do not use oil with MoS₂ additives!

- Push on the clamping assembly and slightly tighten the screws. Align the hub
- Tighten the screws evenly in diagonally opposite sequence until all screws are tightened to the specified torque ↓

Screw	M4	M5	M6
Torque in Nm	2.9	6	10

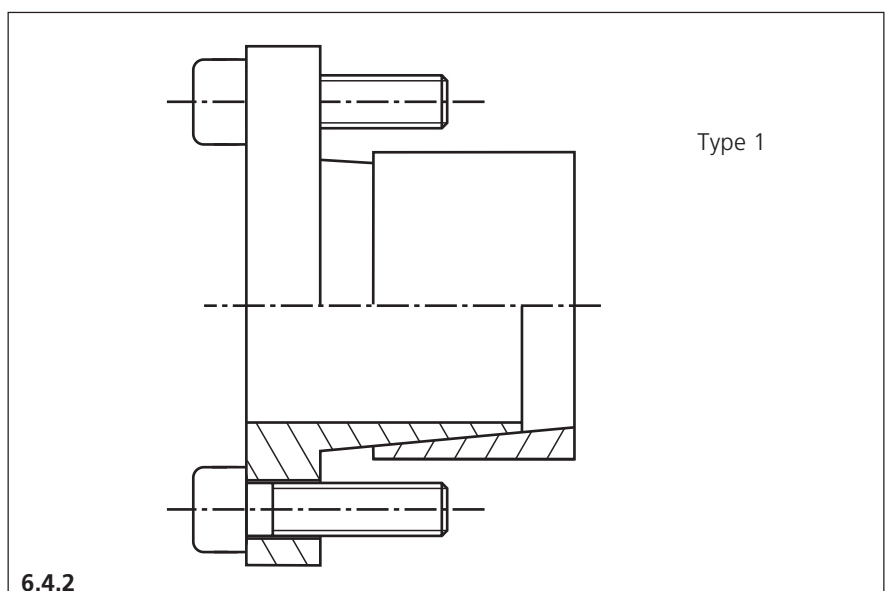

6.4.2



Mounting clamping assembly Type 2

- Slightly oil the clamping elements.
- ⚠ Do not use oil with MoS₂ additives!**
- Push on the clamping assembly.
- The clamping elements must be pushed all the way into the bore of the belt pulley.
- Tighten the screws evenly in **diagonally** opposite sequence until all screws are tightened to the specified torque ↓

Screw	M2,5	M3	M4	M5
Torque in Nm	1.2	2.1	4.9	9.7

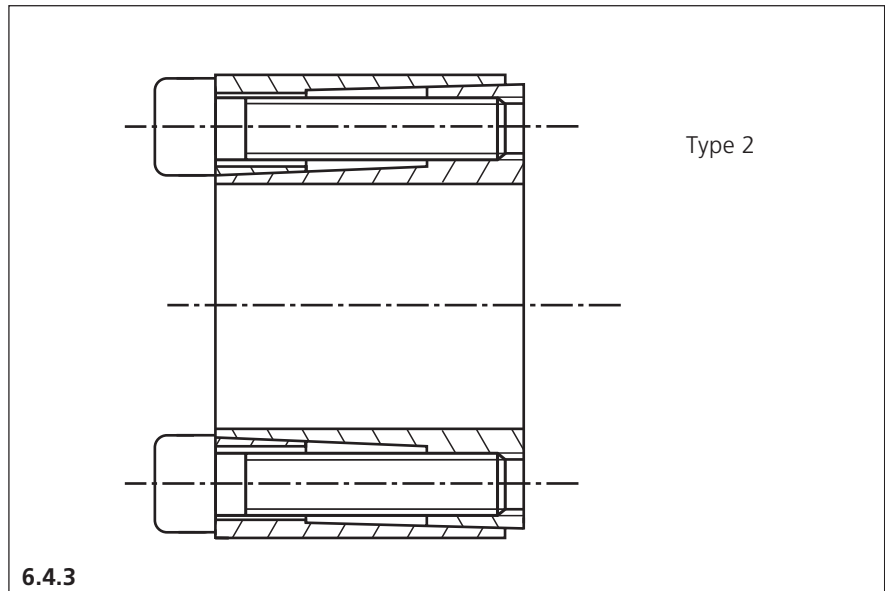

Mounting the second belt pulley and motor with $i=1$

- To ensure that the second pulley can be mounted without problem, the motor must first be pre-mounted as close as possible to the ball rail table.
- Fit the belt pulley and clamping assembly to the motor journal.
- Set clearance B from the housing.
- Mount the clamping assembly. → [6.4.2](#) or [6.4.3](#)
- Loosen the motor fixing.
- Screw suitable screws into the pretensioning thread (2) provided in each of the two motor strips (1).

The pretensioning force F depends on the sizes of the ball rail tables, motors and belt pulleys and also on the torque. The rated pretensioning values are specified on the inside of the gear cover. If the timing belt side drive is not horizontal on assembly, the inherent weight of the motor must be taken into account!

- Withdraw the motor with pretensioning force F from the ball rail table and screw in the fixing screws. Tightening torques ↓

Screw	M5	M6	M8	M10
Torque in Nm	5.5	9.5	23	46

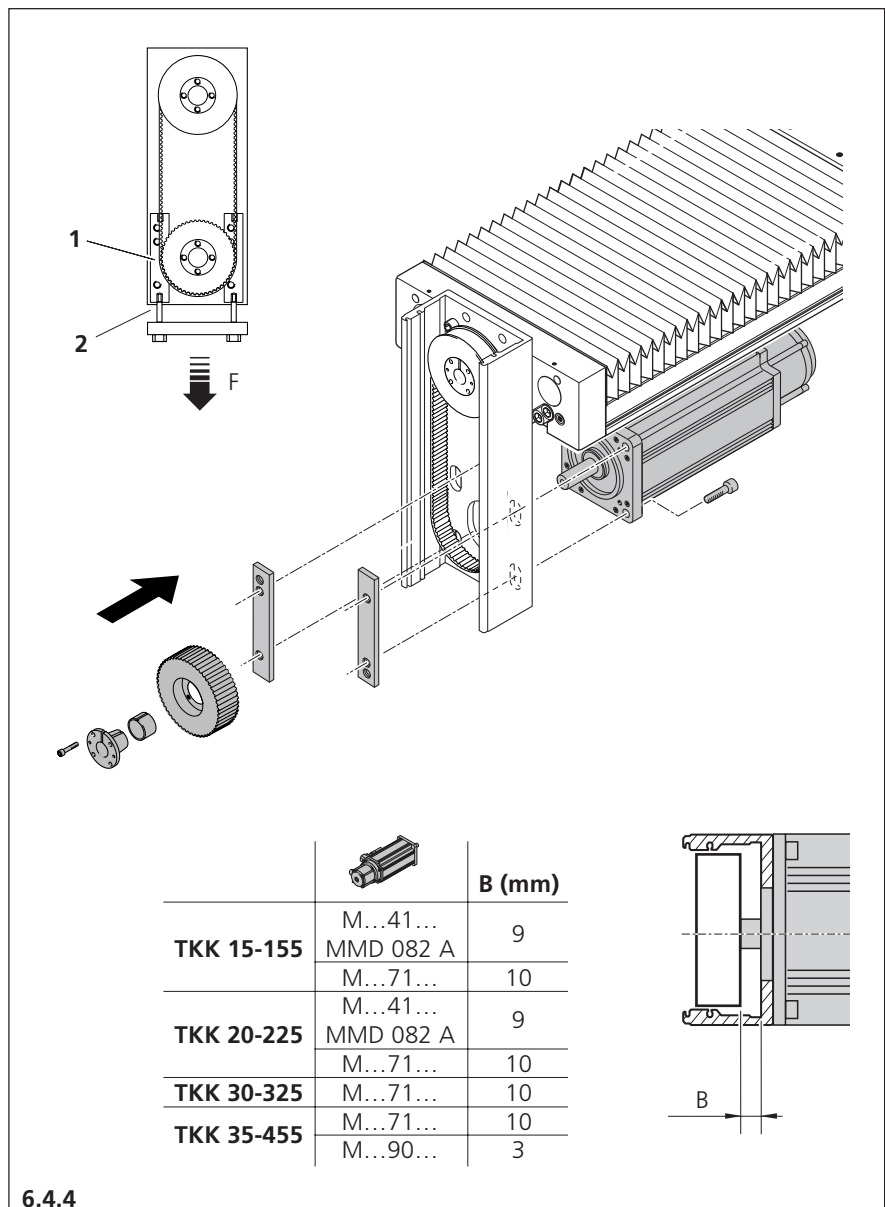



Mounting the second pulley and motor with $i=1.5$ or $i=2$

- Fit the belt pulley and clamping assembly to the motor journal.
- Set clearance C from the housing. Mount the clamping assembly. → [6.4.2](#) or [6.4.3](#)
- To ensure that the second pulley can be mounted without problem, premount the motor as close as possible to the ball rail table.
- Do not tighten the motor fixing screws. Screw suitable screws into the pretensioning thread (2) provided in each of the two motor strips (1).

The pretensioning force F depends on the sizes of the ball rail tables, motors and belt pulleys and also on the torque. The rated pretensioning values are specified on the inside of the gear cover. If the timing belt side drive is not horizontal on assembly, the inherent weight of the motor must be taken into account!

- Withdraw the motor with pretensioning force F from the ball rail table and screw in the fixing screws. Tightening torques ↓

Screw	M5	M6	M8	M10
Torque in Nm	5.5	9.5	23	46

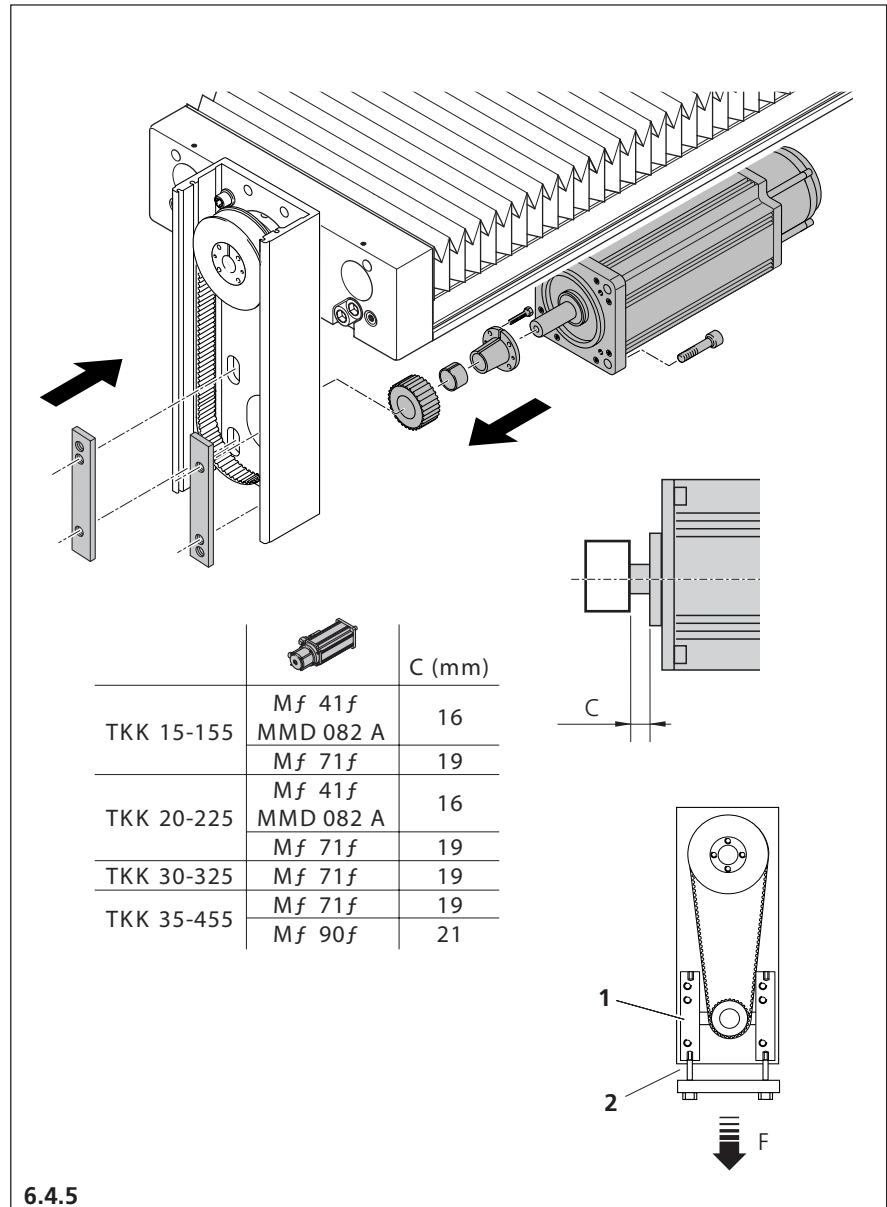

6.4.5

Completing the installation

- Fix all covers to the housing of the timing belt side drive.

⚠ Before using for the first time, check the EMERGENCY STOP switch!

Run through the first operating cycles at reduced speed in order to test the operation of the limit switches and the interaction of mechanical and electronic systems.

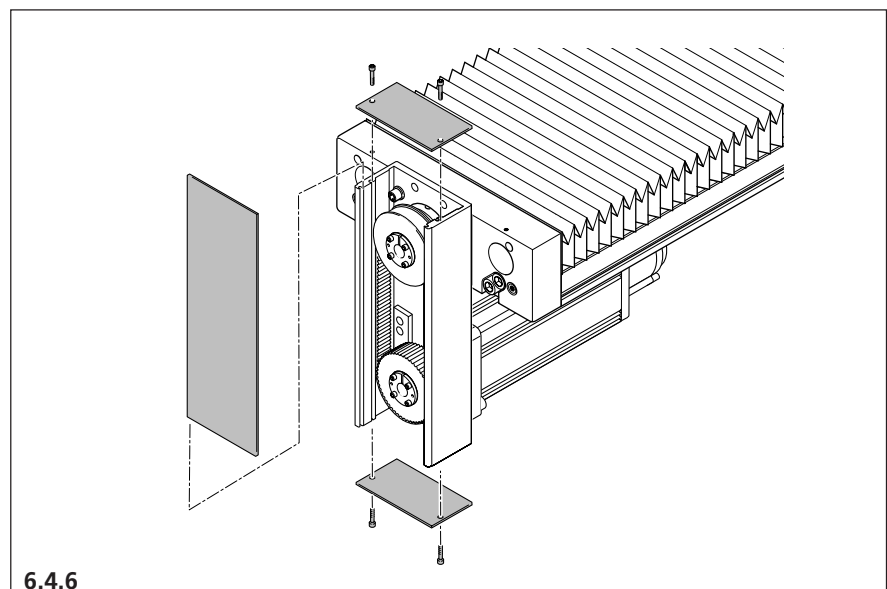

6.4.6



6.5 Dismantling the motor and timing belt side drive

 If the ball rail table is mounted vertically or at an inclined angle, the carriage must be prevented from crashing down!

 Disconnect from mains!

Remove the housing covers.

 The toothed timing belt is pretensioned. Caution is required when loosening the motor fixing screws.

- Push the motor as close as possible to the ball rail table.
- If the two belt pulleys are the same size, loosen the lower clamping assembly.
- Fully unscrew the motor fixing screws. Remove the motor.

To dismantle the timing belt side drive please take account of the different installation variants. Threaded extractor holes are provided in the clamping assemblies to assist dismantling.

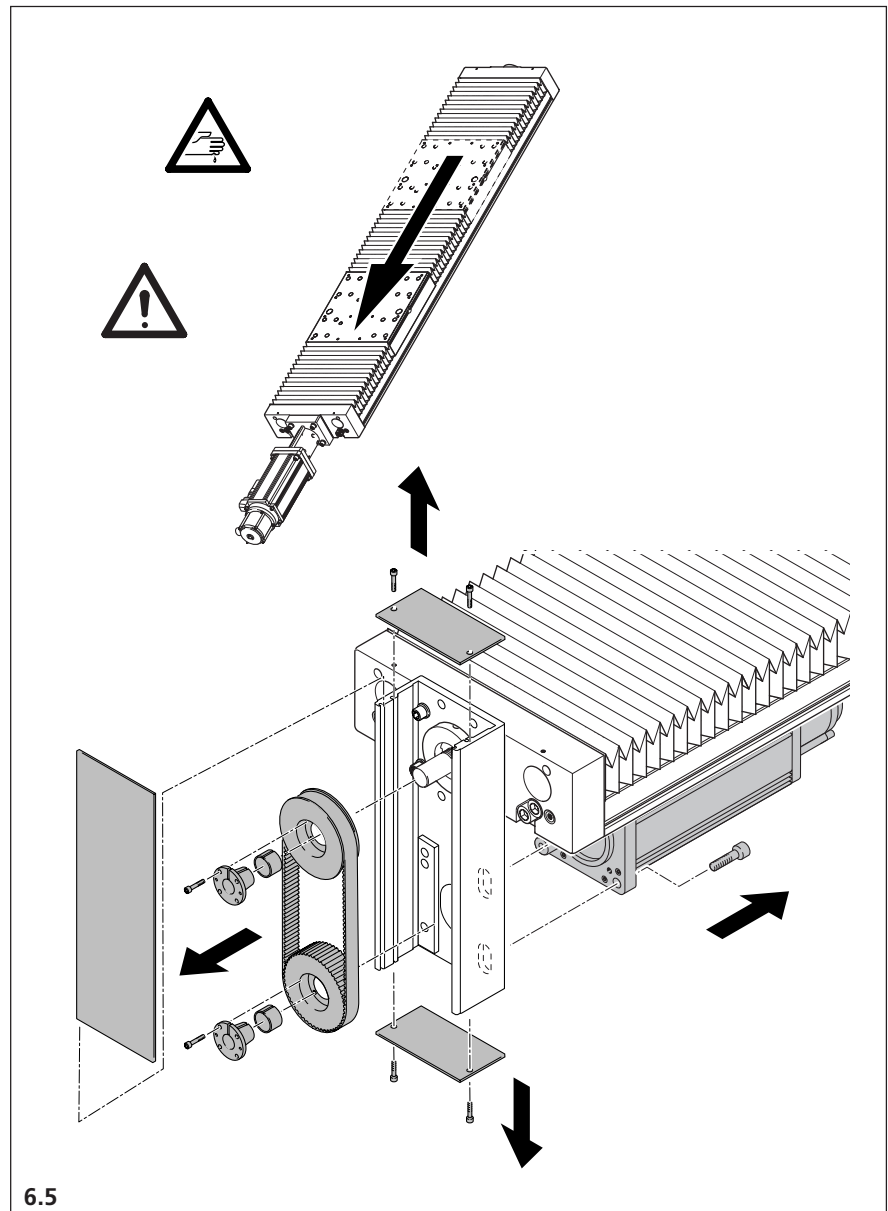

7. Maintenance

Basic lubrication by the manufacturer has reduced the maintenance requirement to relubricating the guide rails and of the ball screw drives in accordance with operating conditions.

The fixed and floating bearings are greased for life, and therefore under normal operating conditions they do not need to be relubricated.

Lube nipples

Lube nipple ports (S1) are located on both sides of the carriage.

- It is sufficient to lubricate on one side.

Size of the lube nipples

TKK 15-155: DV1 - 6
TKK 20-225, TKK 30-325, TKK 35-455: DIN 3405 AM 8x1

Lubricants

⚠ The one-point lubrication system of the ball rail tables is only suitable for lubricating with grease!

⚠ Greases containing solid lubricants (e.g. graphite and MoS₂) must not be used!

The following lubricants are recommended:

- lithium soap grease KP2K (DIN 51825)
- consistency class NLGI 2 (DIN 51818)

Lubrication intervals

Under normal operating conditions:

- ... Temperature 10 f 30°C
 - ... Travel speed < 1 m/s
 - ... Load < C/2
 - ... Stroke > 80 mm
 - ... Speed of ball screw drive < 2500 rpm
- every 0.5 to 1 · 10⁵ m stroke travel or every 500 operating hours, whichever is reached first.

- In the case of special operating conditions (e.g. special installation type, dust, solvents), the lubrication intervals must be adapted to the conditions of use.

Lubricant quantities

Per lubricating interval as a function of the size and design of ball screw drive (BSD): see Table

- When lubricating manually with the grease-gun, measure out the quantity of grease per stroke.

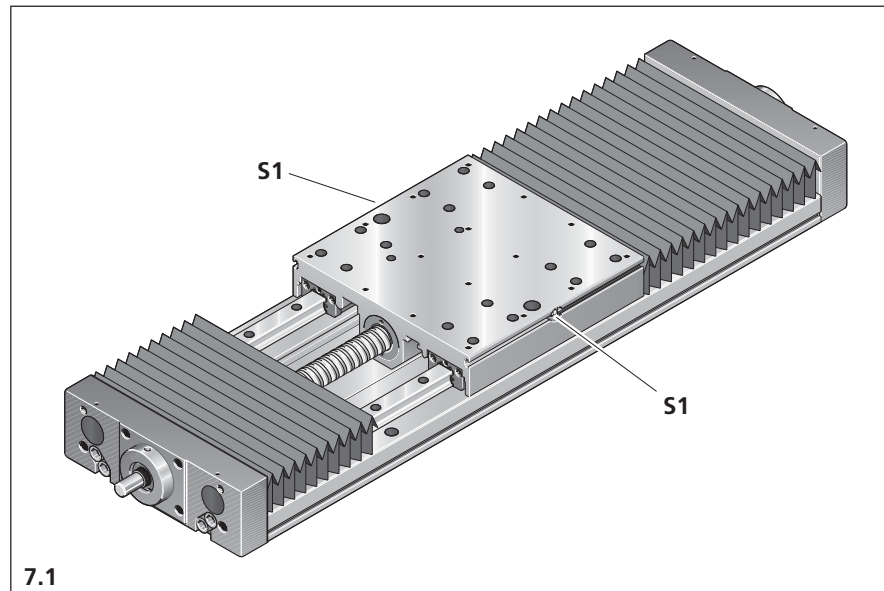

7.1

Lubricant quantity per lubricating interval

Size	BSD (d x P)	Lubricant quantity
		(g)
TKK 15 - 155	16 x 10	3,7
	16 x 16	3,8
	20 x 5	4,5
	20 x 20	6,5
TKK20 - 225	20 x 5	5,7
	20 x 20	7,7
	25 x 5	6,4
	25 x 10	7,7
	25 x 25	11,0
TKK 30 - 325	32 x 5	12,9
	32 x 10	14,9
	32 x 20	16,2
	32 x 32	18,8
TKK 35 - 455	40 x 5	15,3
	40 x 10	24,7
	40 x 20	27,3
	40 x 40	30,7

7.2



8. Mounting assemblies and wear parts

8.1 Overview

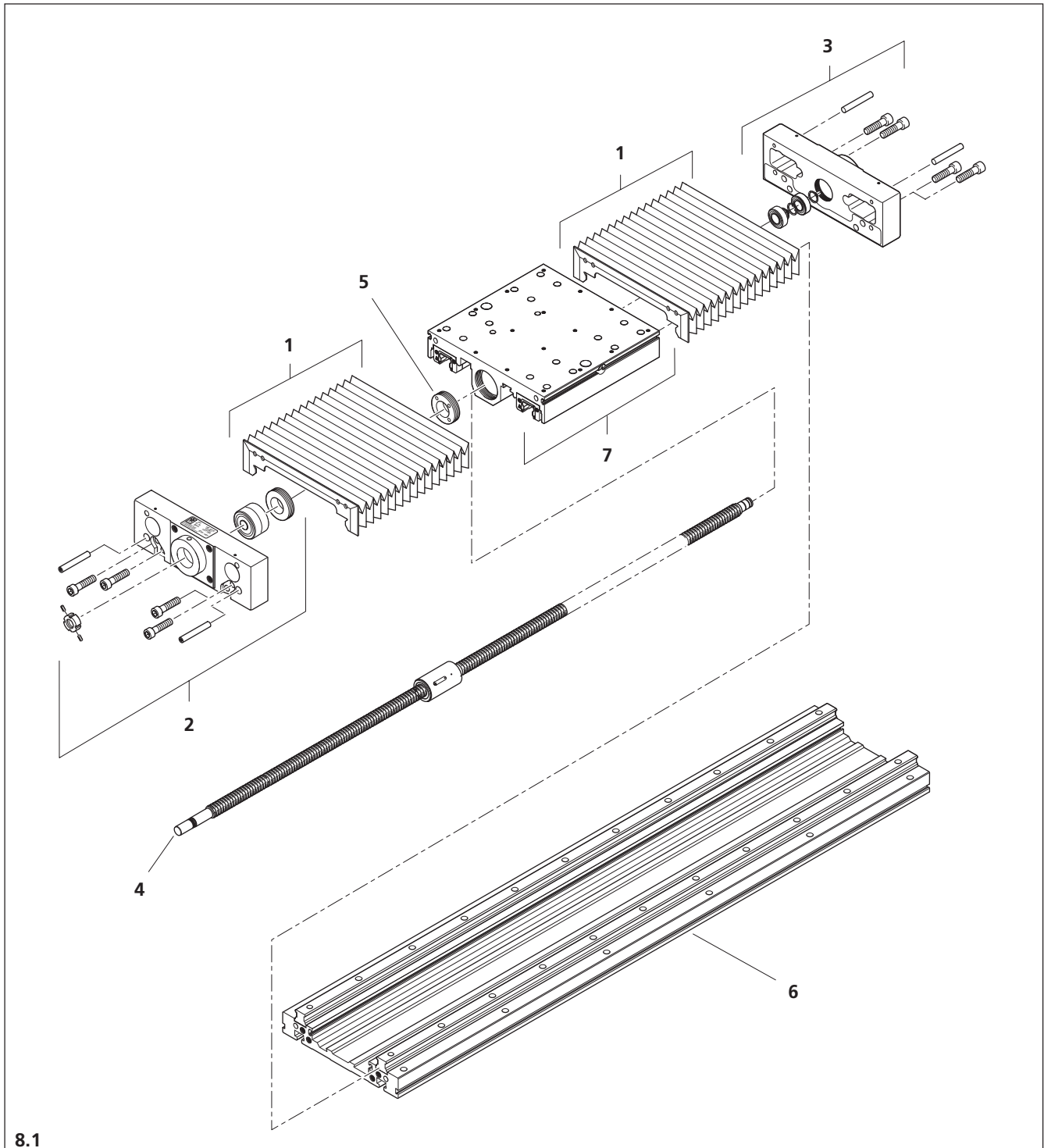



Item	Component MG = Mounting Group WP = Wear Part	For instructions see Section
1	MG Bellows WP Bellows Fixings	8.2 " "
2	MG Fixed bearing Fixed bearing block WP Fixed bearing Threaded ring Slotted nut Cheese-head screw / Straight pin	8.3 " " " " "
3	MG Floating bearing Floating bearing block WP Ball bearing Circlip Cheese-head screw / Straight pin	8.4 " " " "
4	MG Ball screw drive (BSD)	8.5
5	Threaded ring	8.5
6	MG Base plate Base plate Ball rail system (guide rail)	8.7 " "
7	MG Carriage Carriage Ball rail system (guide rail) Attachments	8.7 " " "
Please ask Bosch Rexroth for lists of wear parts.		



8.2 Dismantling/mounting bellows

Dismantling the bellows:

⚡ Disconnect from mains before dismantling!

- For ball rail tables with timing belt side drives, remove the covers of the side drive. ➡ 6.5

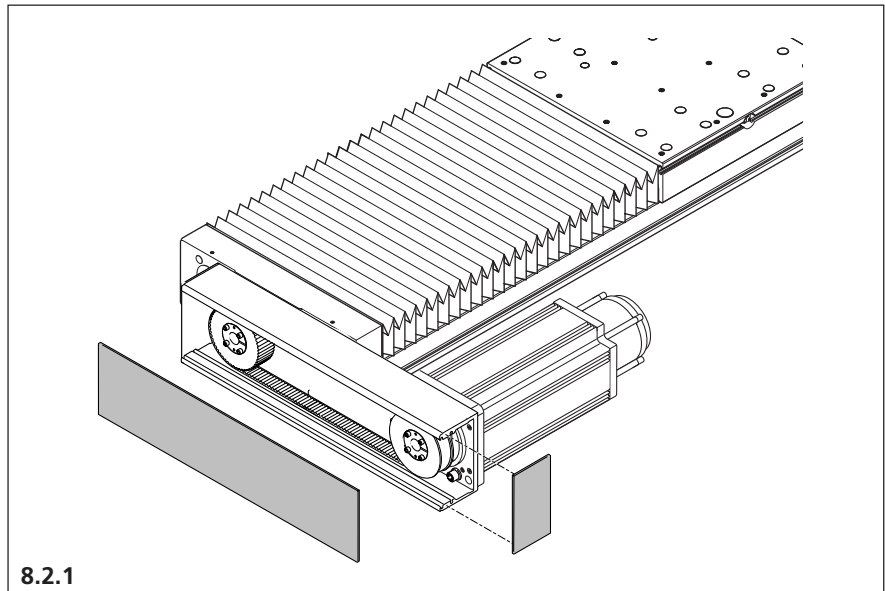

8.2.1

- Unscrew the bellows from the bearing block (1).
- Remove the inner frame (2).

⚠ Do not tear the bellows!

- Pull the bellows up to the carriage. If necessary, grip from underneath with the other hand.
- Unscrew the bellows from the carriage (3).
- Remove the other inner frame.

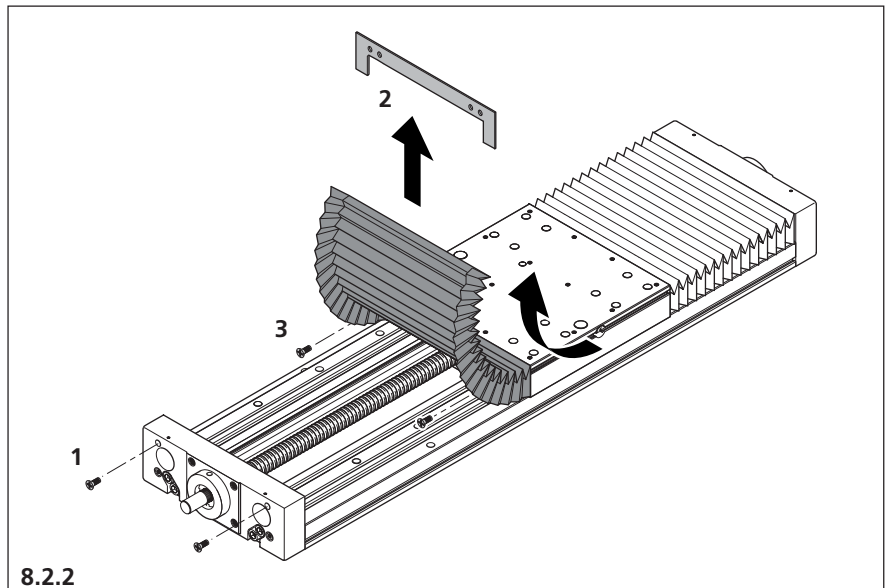

8.2.2

Mounting the bellows

- Fit the inner frame (4) in the first or last fold so that one stiffening rib of the bellows is clamped with the frame.
- Screw the bellows to the carriage (3).
- Tightening torque for M4 screws: 2 Nm. For M5: 3.8 Nm.
- Insert the bellows at the fixed or floating bearing end.
- Hold the inner frame (2) firmly against the bearing block and screw to the bearing block (2). Tightening torque for M4 screws: 2 Nm. For M5: 3.8 Nm.

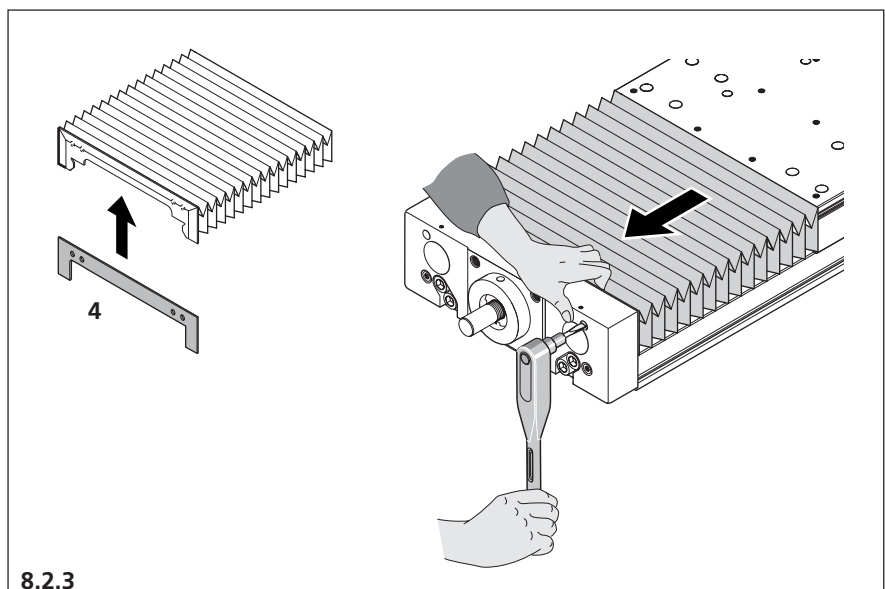

8.2.3



8.3 Replacing the fixed bearing

Removing the bearing block together with the fixed bearing

If the ball rail table is installed vertically or at an inclined angle, the carriage must be prevented crashing down!

- Move the carriage to its mid-position.
Remove the motor. ➡ 6.3 or 6.5
- Dismantle the bellows. ➡ 8.2
If a plug is plugged into the bearing block, disconnect it from the socket.
- Loosen the socket locating set screw (1).
- Unscrew the set screws (2) in the slotted nut.
- Clamp the BSD screw in position. .
Use plastic jaws!!
- Unscrew the slotted nut (3).
Remove the internally threaded straight pins (4).
- Unscrew the cheese-head screws (5).
- Remove the bearing block and fixed bearing carefully from the screw of the BSD, keeping them perfectly straight.

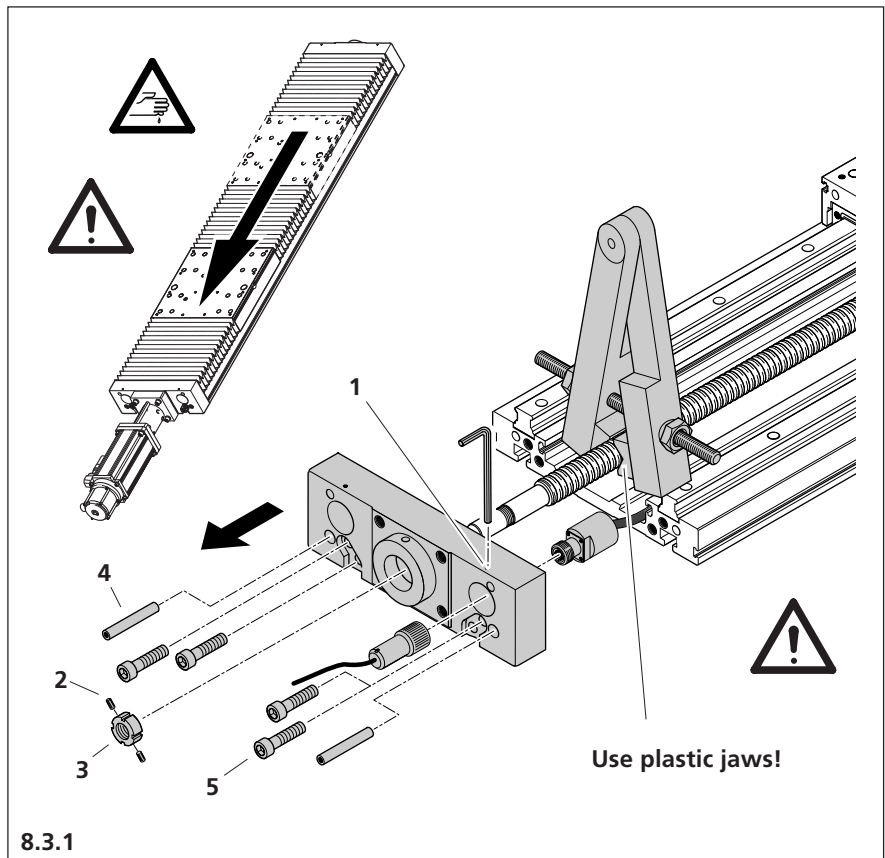

Removing the fixed bearing (angular contact ball bearing) from the bearing block

Fit plastic jaws to the vice.

Clamp the bearing block in the vice.

The screwed ring is fixed with Loctite 638.

- Heat the screwed ring with a hot air blower until the adhesive starts to run and the screwed ring can be loosened.
- Unscrew and remove the screwed ring with a ring wrench.
- Lay the bearing block flat on a support with a recess under the fixed bearing. Carefully push out the fixed bearing.

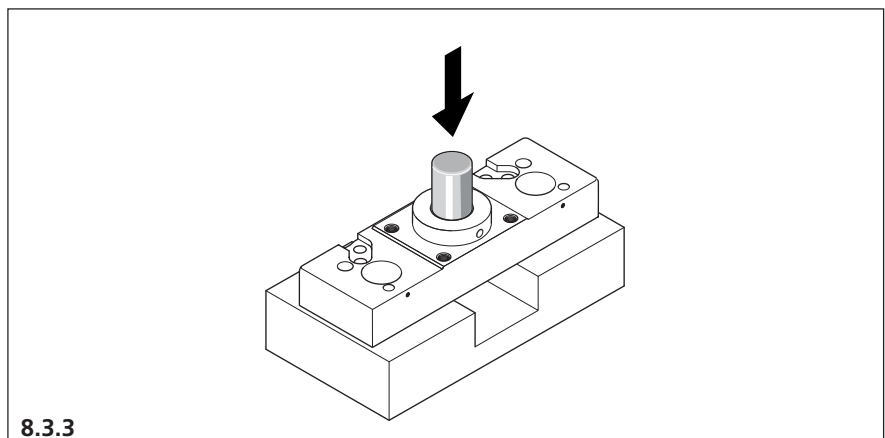
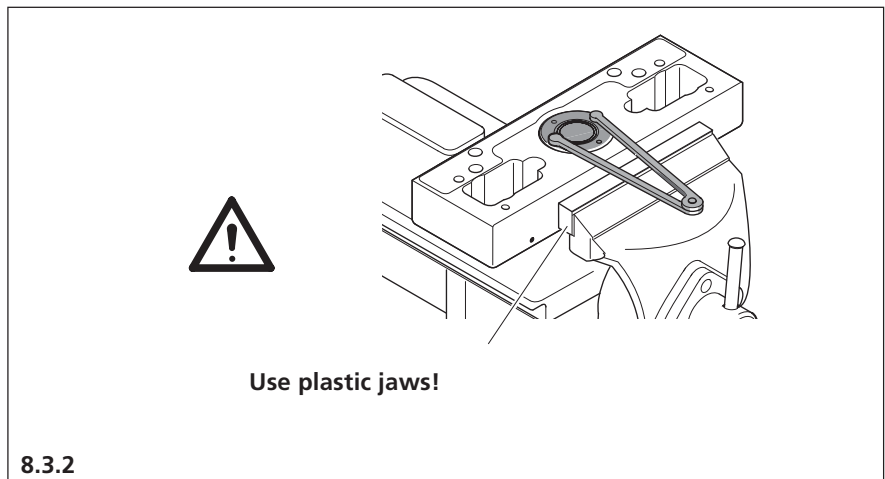



Mounting the fixed bearing in the bearing block

- Turn the block the other way up and lay on a flat surface.
- Insert the new fixed bearing carefully in the bearing block as far as it will go. Do not skew the bearing and do not apply force to the inner bearing ring!
- Coat the threaded ring with Loctite 638 adhesive and screw down firmly.

Threaded ring tightening torques:		
TKK 15-155	M45x1.5	28 Nm
TKK 20-225	M45x1.5	28 Nm
	M50x1.5	34 Nm
TKK 30-325	M55x1.5	52 Nm
TKK 35-455	M65x1.5	68 Nm

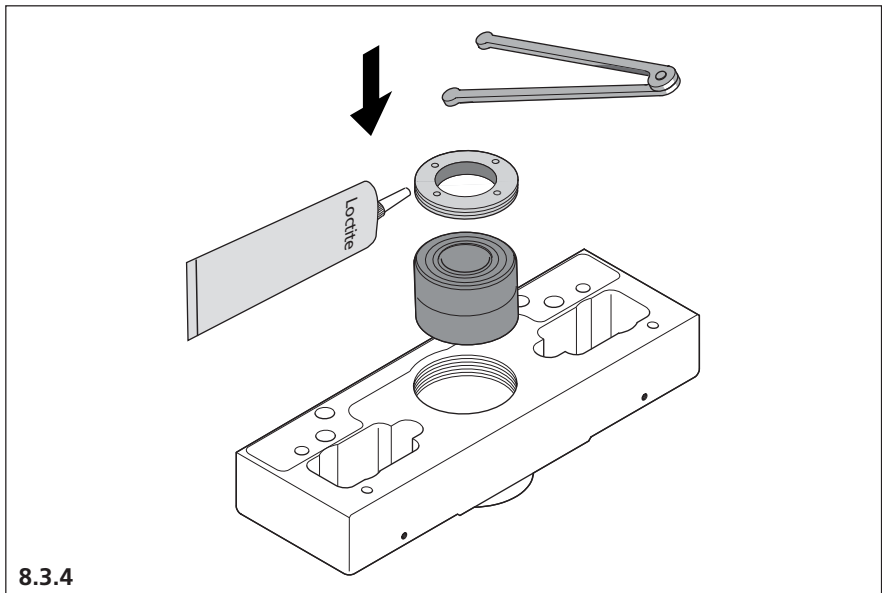

8.3.4

Mounting the bearing block and fixed bearing assembly

- Push the bearing block with premounted fixed bearing on to the screw of the BSD.
- Clamp the screw in position, using plastic jaws.
- Tighten the slotted nut (1) with three times the rated torque and then reloosen and finally tighten with the specified torque. This process pretensions the fixed bearing.
- Fix the slotted nut with two set screws

Tightening torques			
	Slot nut		Set screw
TKK 15-155	M12x1.0	8 Nm	2 Nm
TKK 20-225	M12x1.0	8 Nm	2 Nm
	M17x1.0	15 Nm	4 Nm
TKK 30-325	M20x1.0	18 Nm	4 Nm
TKK 35-455	M30x1.5	32 Nm	7 Nm

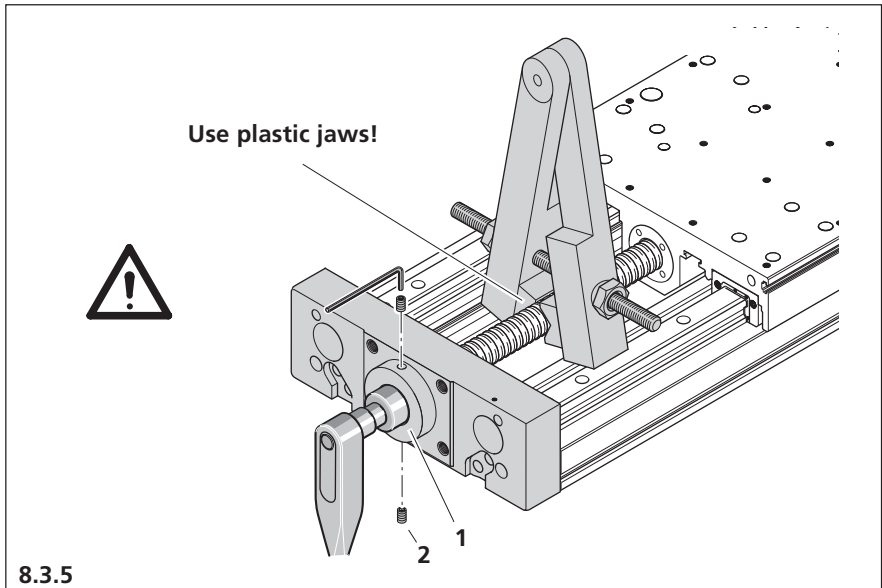

8.3.5

- Slightly tighten the cheese-head screws
- Drive in the straight pins (4).
- Tighten the cheese-head screws with the specified tightening torque ↓

Screw	M8	M12	M16
Torque in Nm	23	80	195

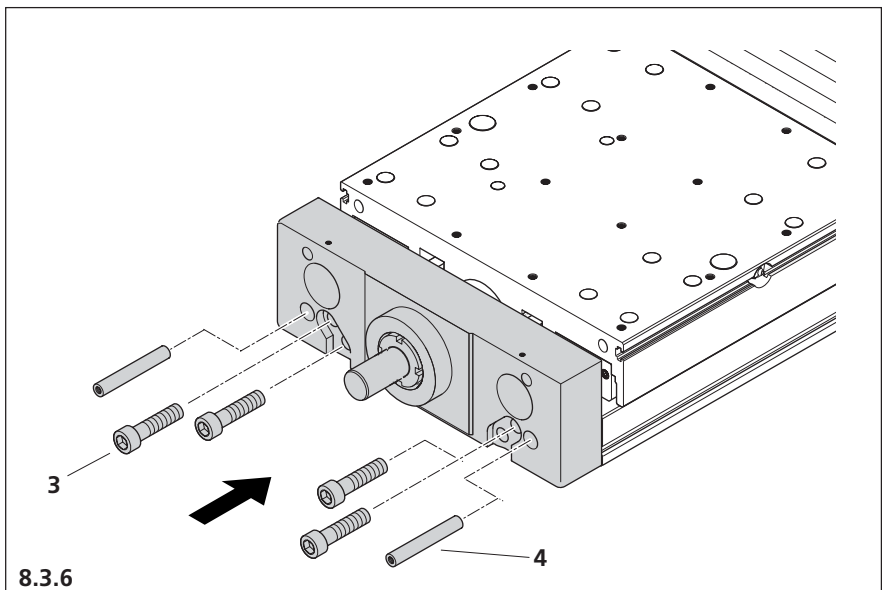

8.3.6



8.4 Replacing the floating bearing

Removing the floating bearing

- If necessary, dismantle the motor and timing belt side drive. ➔ 6.5
- Remove the bellows at the floating bearing end. ➔ 8.2
- If a socket and plug is mounted in the bearing block, remove the plug from the socket. Loosen the socket locating set screw (1).
- Move the carriage to about 20 mm from the floating bearing.
- Remove the internally threaded straight pins (2).
- Unscrew the cheese-head screws (3).

- Carefully remove the floating bearing block. The bearings remain on the end of the screw. If fitted, the socket remains on the ball rail table.
- Remove the circlips.
- Pull the two bearings off the screw.

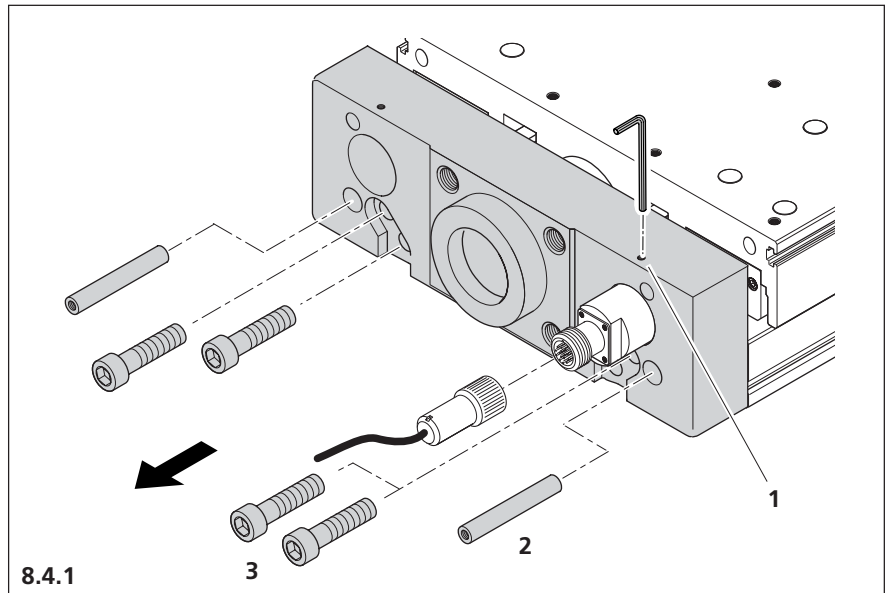

8.4.1

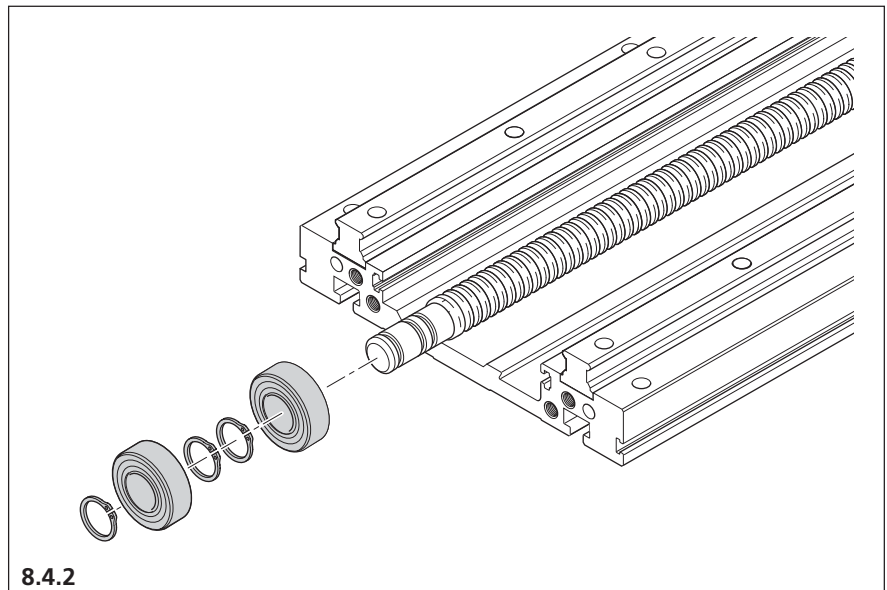

8.4.2

Mounting the floating bearings

⚠ Do not oil the bearings and the end of the screw! Otherwise the bearings may slip in operation!

- Push both floating bearings on to the end of the screw and secure with circlips.
- Carefully push the bearing block over the floating bearings.
- Slightly tighten the cheese-head screws.
- Drive in the straight pins.
- Tighten the cheese-head screws with tightening torque ↓.

Screw	M8	M12	M16
Torque in Nm	23	80	195

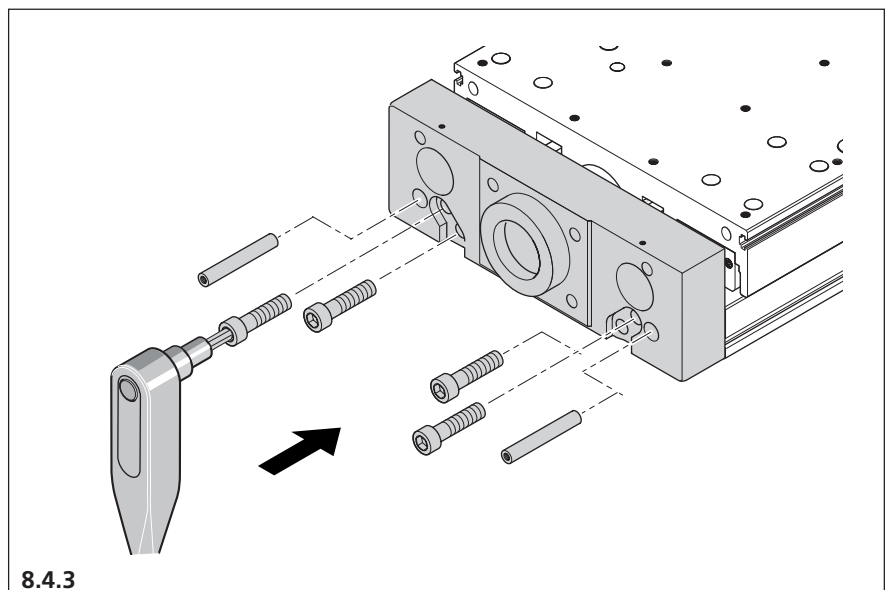

8.4.3



8.5 Replacing the ball screw drive (BSD)

Dismantling the BSD

⚡ Disconnect from the mains before dismantling!

⚠ If the ball rail table is installed vertically or at an inclined angle, the carriage must be prevented from crashing down!

⚠ The BSD may only be replaced complete with the nut. If the nut is removed from the screw, balls will be lost, causing the destruction of the BSD if the nut is remounted.

- Remove the motor complete with motor mount. ➡ 6.3 or 6.5
- Remove the bellows. ➡ 8.2
- Remove the fixed bearing block and fixed bearing. ➡ 8.3
- Remove the floating bearing block and floating bearings. ➡ 8.4

The screwed ring is fixed with Loctite 638.

- Heat the screwed ring with a hot air blower until the adhesive starts to run and the screwed ring can be loosened.
- Unscrew and remove the screwed ring with a ring wrench.

- Prepare V-shaped supports for the screw with a recess for the nut.
- Carefully pull the screw, complete with nut, out of the carriage.
- Lay the screw on the V-shaped supports.

⚠ Do not rest the screw on the nut!

⚠ Significant bending of the screw indicates a danger of permanent deformation!

⚠ Longer screws (1500 mm and more) should be supported or suspended at several support points.

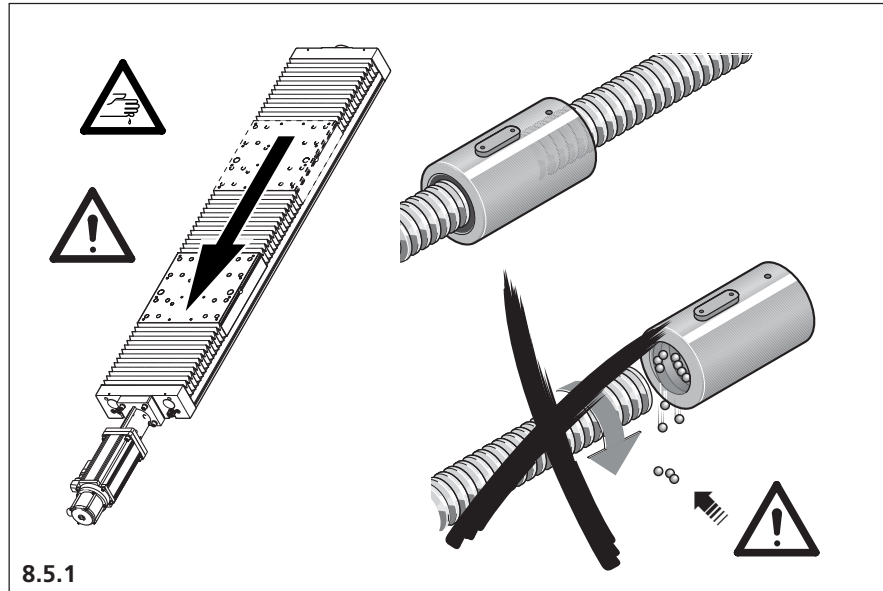

8.5.1

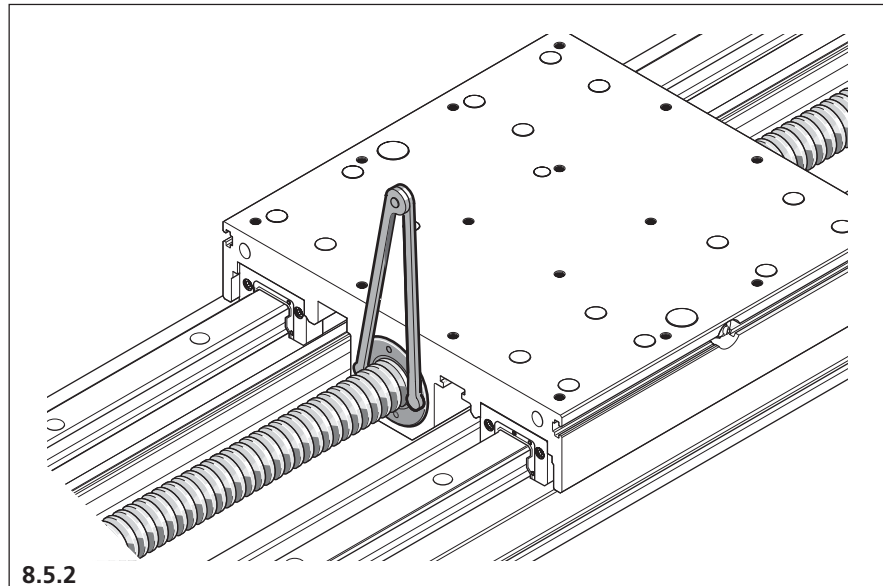

8.5.2

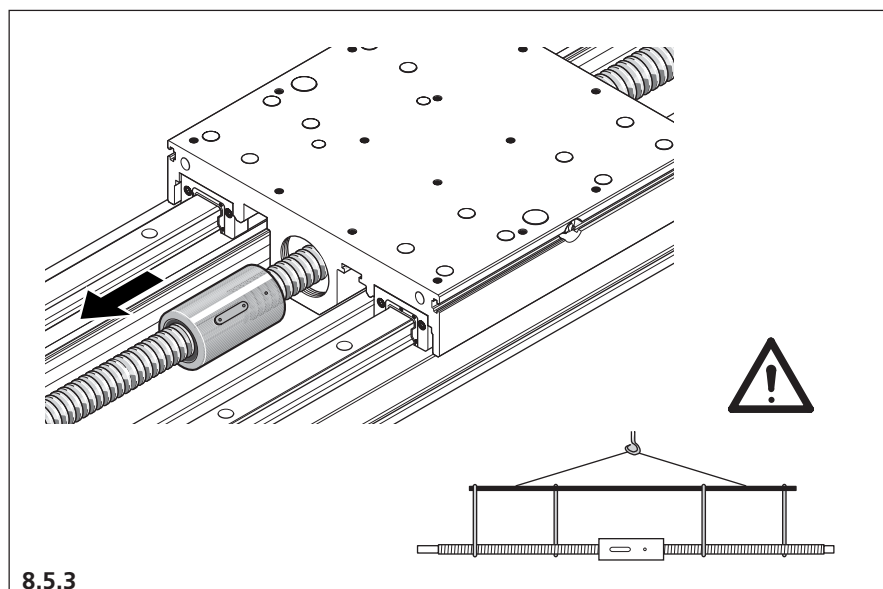

8.5.3



Mounting the ball screw drive (BSD)

- Insert the BSD nut into the carriage, with the lube hole (1) end first, slotting the featherkey (2) into the keyway (3).

⚠ If the BSD nut is not inserted with the lube hole (1) end first, it cannot be lubricated during operation.

- Carefully push the BSD nut and screw into the carriage as far as they will go. Avoid impact.

In several installation variants of the ball rail tables, the nut must be turned 180° on the screw. A mounting sleeve is required for this purpose and can be ordered together with the replacement BSD.

⚠ To turn the nut, please observe the assembly instructions for ball screw drives. These assembly instructions are packed with the replacement BSD.

- Coat the threaded ring with Loctite 638 adhesive and tighten with a ring wrench

Threaded Ring tightening torques:

TKK 15-155	M40x1,5	23 Nm
TKK 20-225	M40x1,5	23 Nm
	M45x1,5	28 Nm
TKK 30-325	M55x1,5	52 Nm
TKK 35-455	M78x2,0	80 Nm

- Mount the bearing block and fixed bearing. ➡ 8.3
- Mount the bearing block and floating bearings. ➡ 8.4
- Mount the bellows. ➡ 8.2
- Mount the motor and motor mount or the timing belt side drive. ➡ 6.1, 6.2 or 6.4

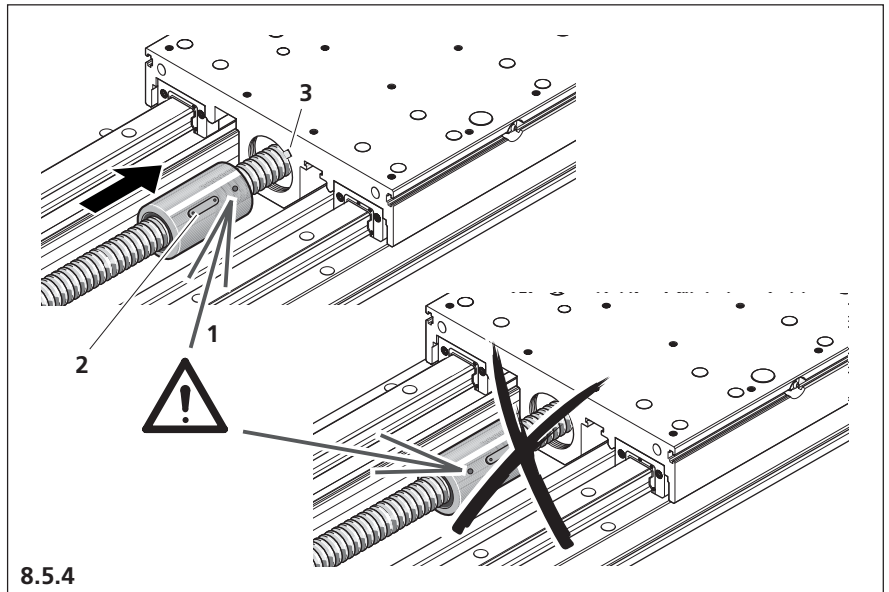

8.5.4

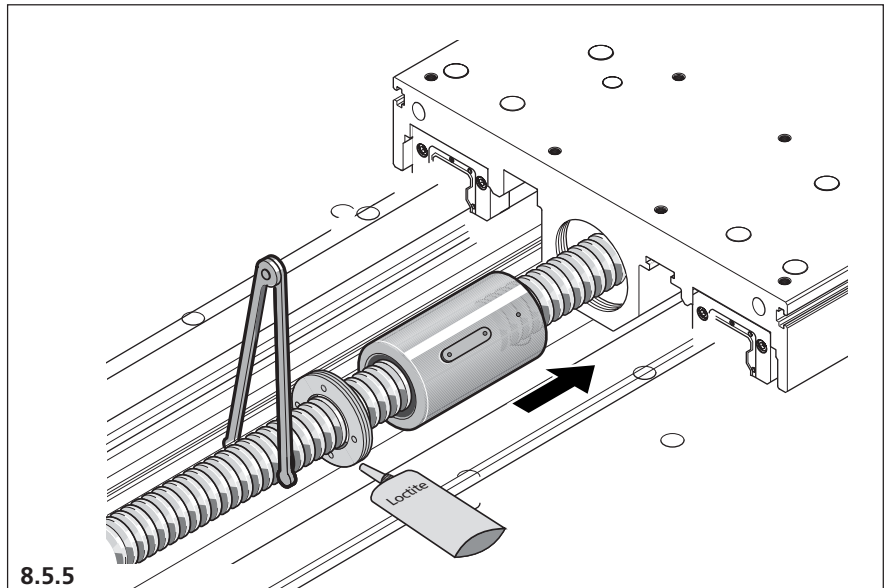

8.5.5

8.6 Replacing the sealing strip

If necessary, please refer to the Mounting Instructions for the Rail Seal Cover Strip

8.7 Replacing the guide rail, carriage or base plate

To ensure the precision of the ball rail table after replacing the guide rails, carriage or base plate, we recommend that for these replacements you return the complete ball rail assembly to Bosch Rexroth Corporation.



8.6

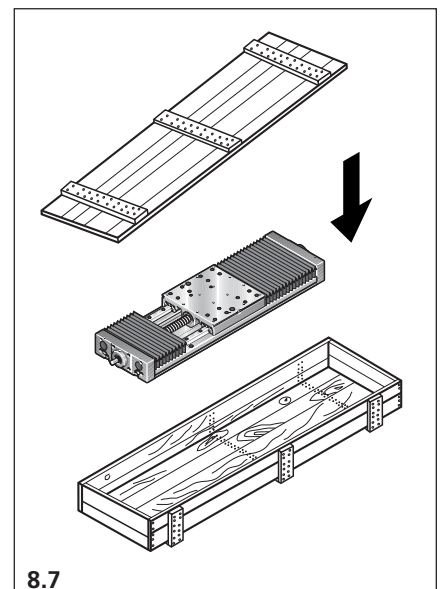

8.7



9. Mounting X-Y tables

9.1 Mounting two ball rail tables of the same size (base plate on carriage)

⚠ The attachments on X-Y tables must be mounted with care to ensure they cannot be damaged!

Note the desired direction of installation. ➡ [9.1.1](#)

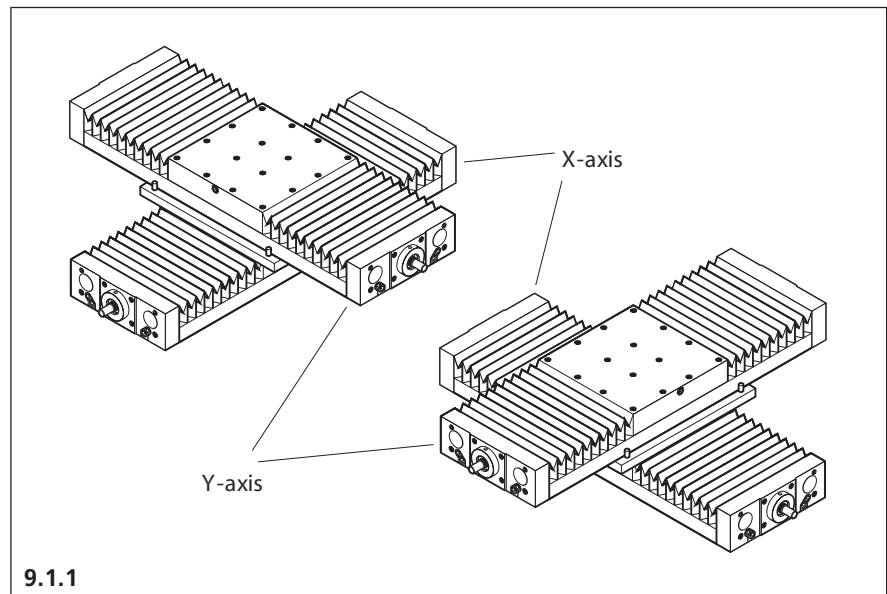

9.1.1

- Fix the cross-plate to the X-axis carriage with screws (1) and pins (2).
- Insert the straight pins (3) for locating the Y-axis base plate.

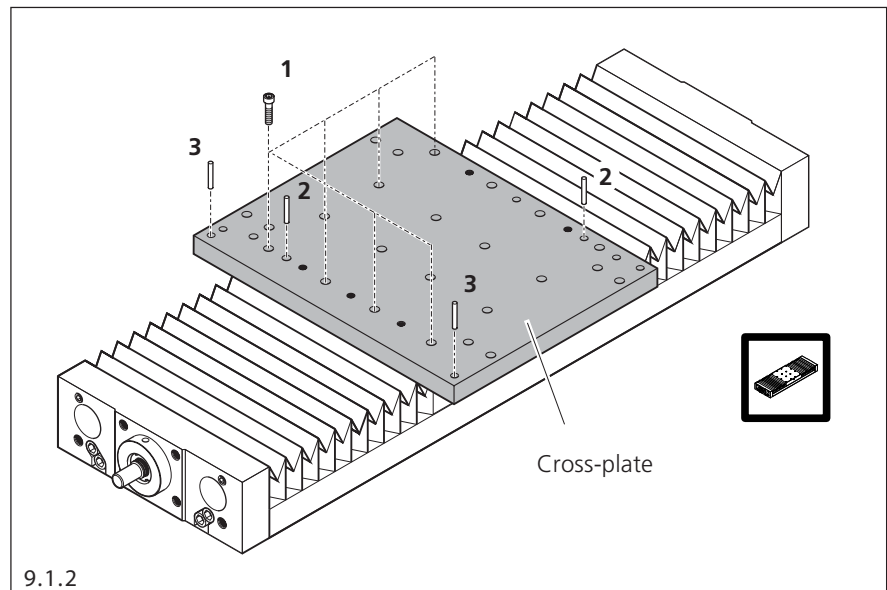

9.1.2

- Insert and position four pairs of T-nuts (4) in the T-slots of the Y-axis base plate.
- Place the Y-axis table on the cross-plate and lay it with the reference edge of the base plate (5) on the locating pins (3).

- Fix the cross-plate from underneath to the Y-axis base plate or to the ready-positioned T-nuts using screws (6).
- Move the Y-axis carriage away from the cross-plate zone by turning the BSD (7).
- Remove the Y-axis bellows covering the cross-plate zone. ➡ 8.2
- Fix the Y-axis base plate to the cross-plate from above with screws (8) in the corresponding threaded cross-plate holes.

- Drill holes in the Y-plate base plate from underneath through the pre-drilled pin holes in the cross-plate (transfer the drill-hole pattern of the cross-plate to the base plate), deburr and fix with pins (9).

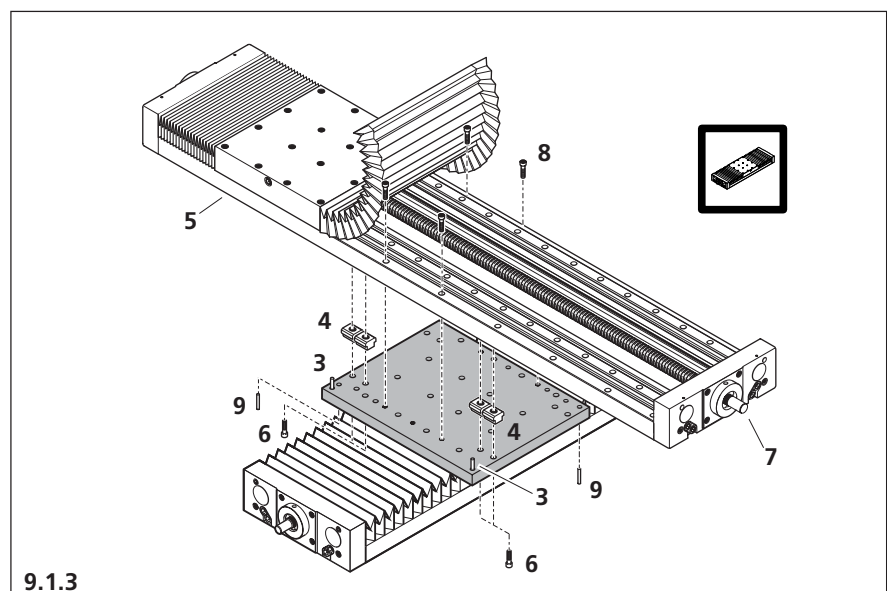

9.1.3



9.2 Mounting a ball rail table of the next smaller size (base plate on carriage)

⚠ The attachments on X-Y tables must be mounted with care to ensure they cannot be damaged!

- Drive straight pins (1) into the cross-plate for locating the Y-axis base plate.
- Insert and position four pairs of T-nuts (2) in the T-slots of the Y-axis base plate.
- Place the Y-axis table on the cross-plate and lay it with the reference edge of the base plate (3) on the locating pins (1).
- Fix the cross-plate from underneath to the Y-axis base plate or to the ready-positioned T-nuts using screws (4).
- Move the Y-axis carriage away from the cross-plate zone by turning the BSD (5).
- Remove the Y-axis bellows covering the cross-plate zone. ➡ 8.2
- Fix the Y-axis base plate from above to the cross-plate with screws (6) in the corresponding threaded cross-plate holes.
- Drill holes in the Y-axis base plate from underneath through the pre-drilled pin holes in the cross-plate (transfer the drill-hole pattern of the cross-plate to the base plate), deburr and fix with pins (7).

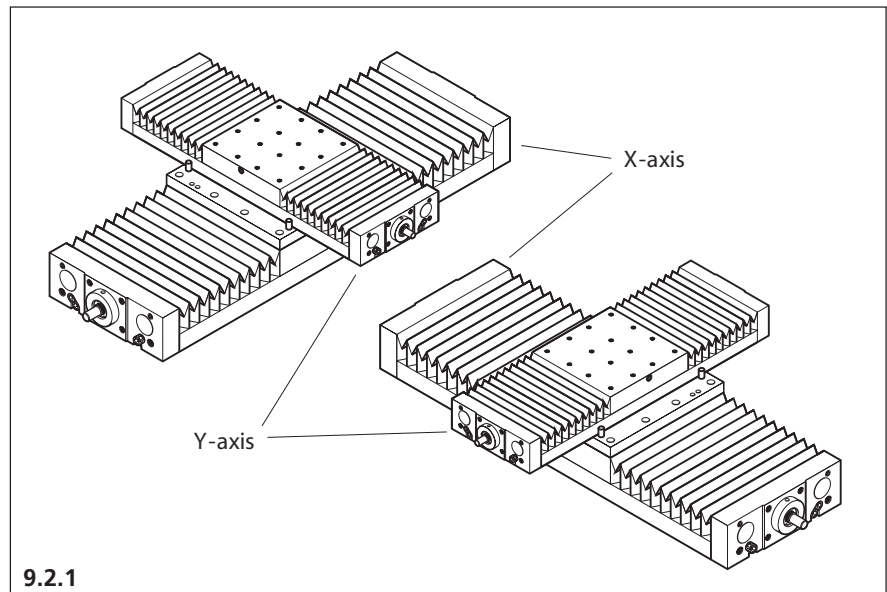

9.2.1

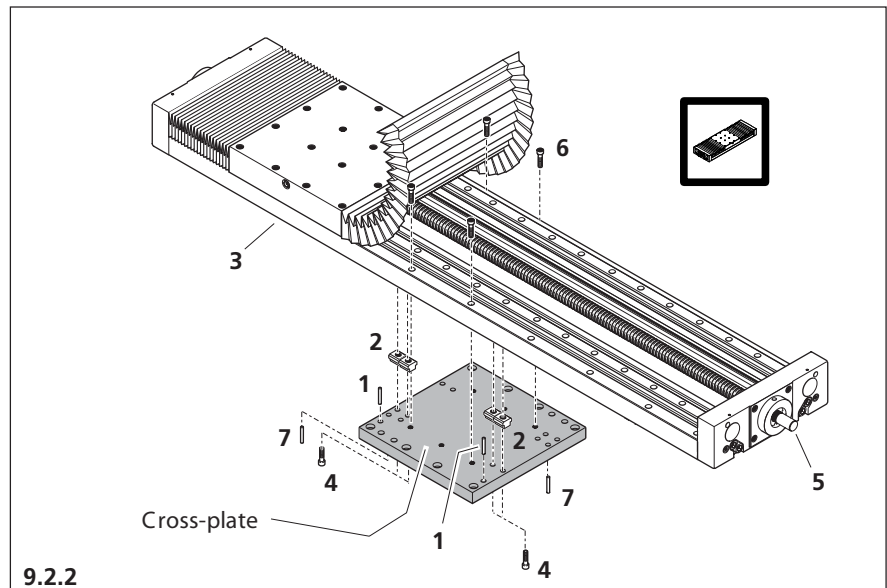

9.2.2

- Note the desired direction of installation. ➡ 9.2.1
- Place the Y-axis table with mounted cross-plate on the carriage of the X-axis table.
- Fix the cross-plate from above to the X-axis carriage with screws (8) and pins (9).

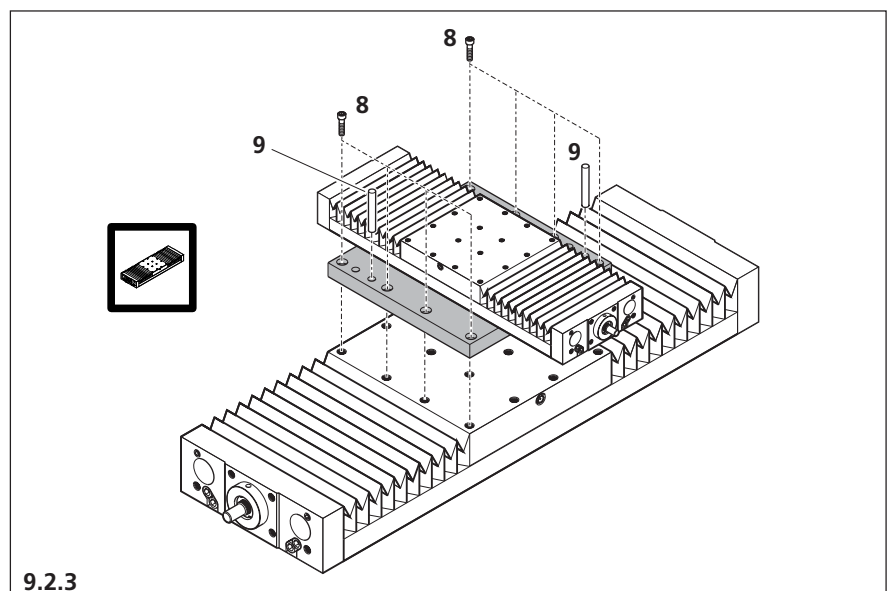

9.2.3



9.3 Mounting two ball rail tables of the same size (carriage to carriage)

 The attachments on X-Y tables must be mounted with care to ensure they cannot be damaged!

- Note the desired direction of installation. ➔ [9.3.1](#)

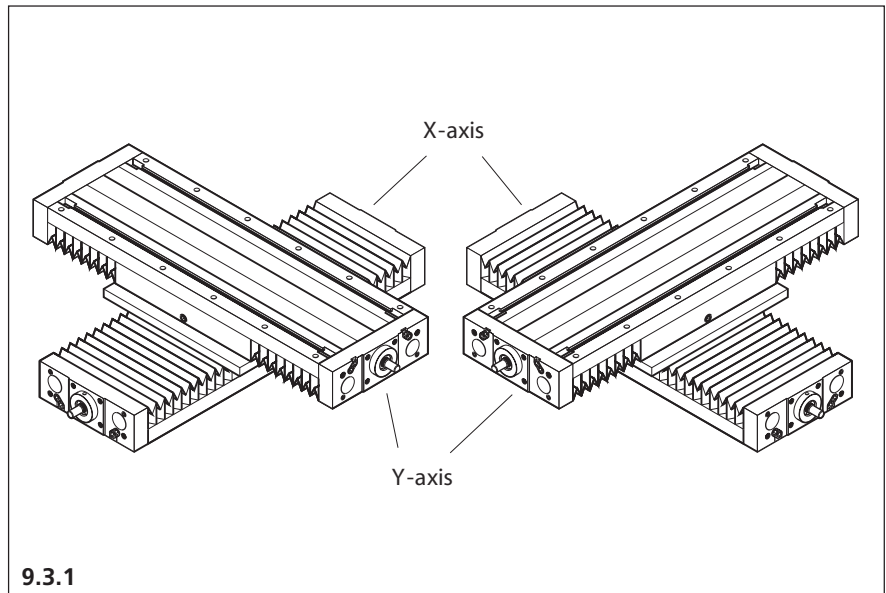

- Screw and pin the cross-plate to the X-axis carriage.

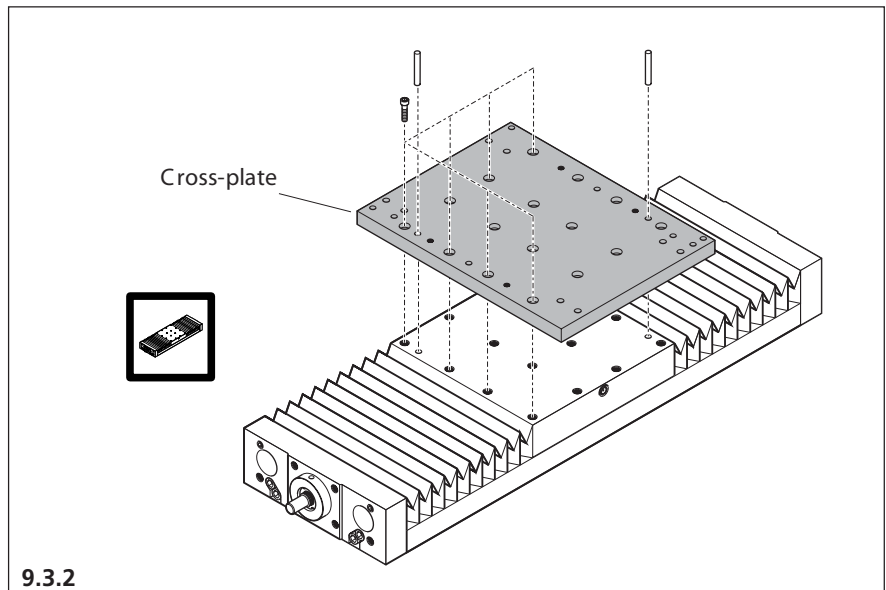

- Place the Y-axis ball rail table upside down on the cross-plate.
- Screw and pin the cross-plate from underneath to the Y-axis carriage.

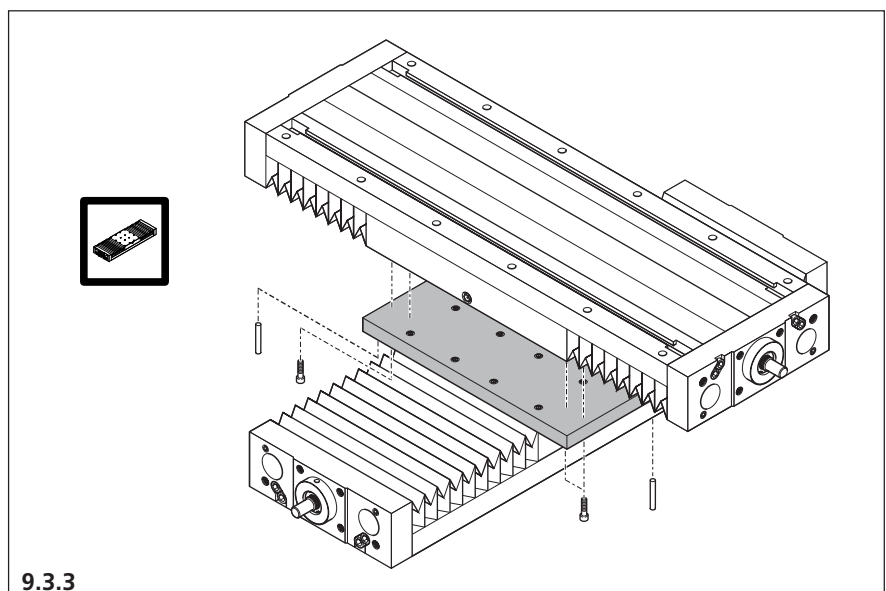



9.4 Mounting a ball rail table of the next smaller size (carriage to carriage)

 The attachments on X-Y tables must be mounted with care to ensure they cannot be damaged!

- Note the desired direction of installation. ➔ [9.4.1](#)

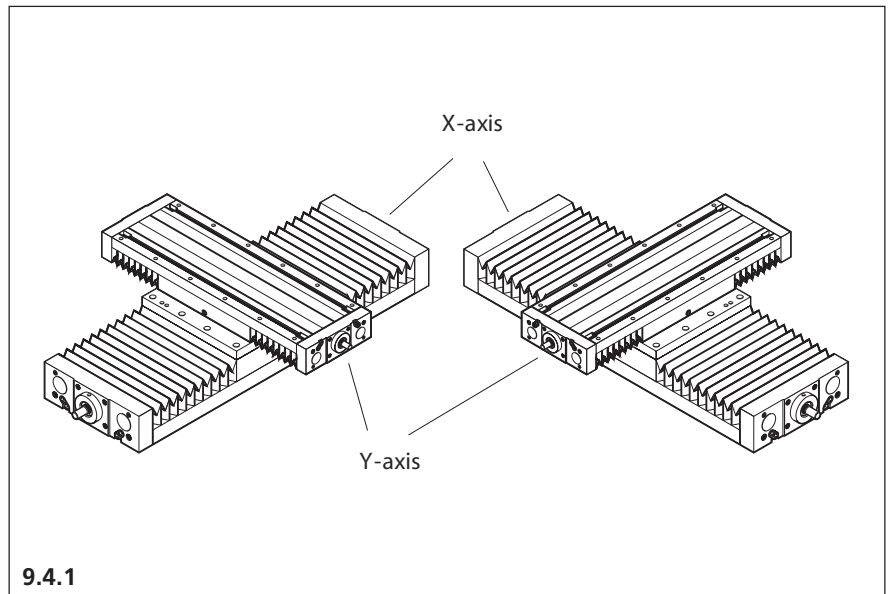

- Screw and pin the cross-plate to the Y-axis carriage.

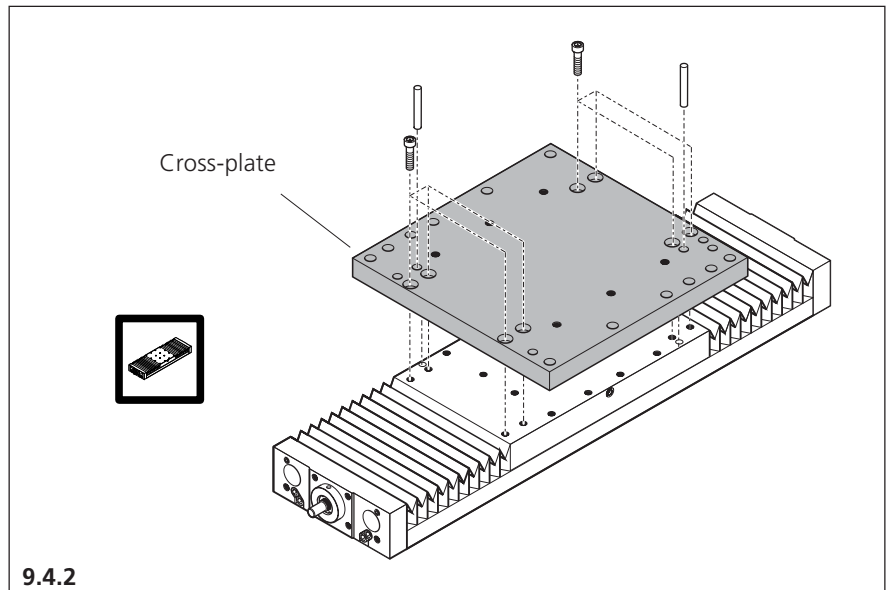

- Place the Y-axis ball rail table, complete with mounted cross-plate, upside down on the X-axis carriage.
- Screw and pin the cross-plate from above to the X-axis carriage.

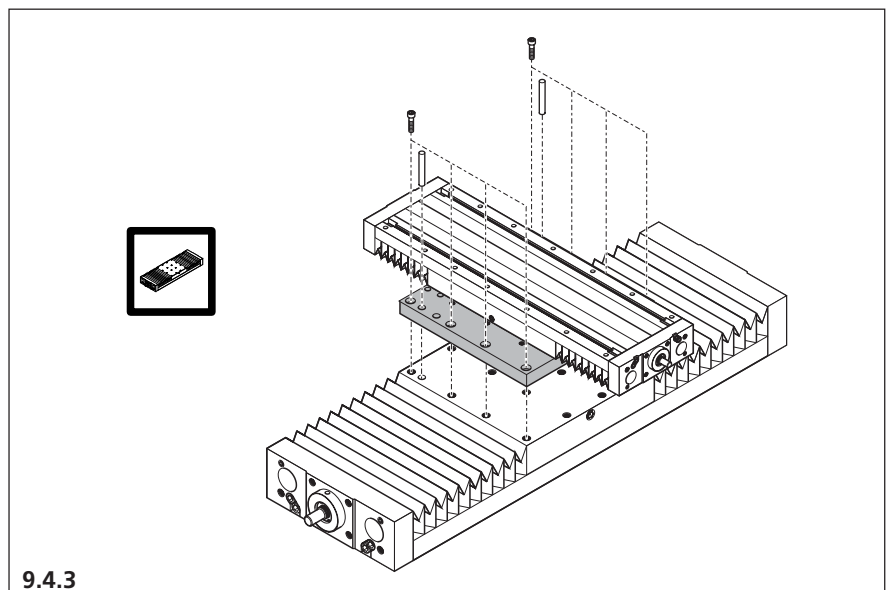

Bosch Rexroth Corporation
Linear Motion and
Assembly Technologies
14001 South Lakes Drive
Charlotte, NC 28273
Telephone (800) 438-5983
Facsimile (704) 583-0523
www.boschrexroth-us.com

Bosch Rexroth Corporation
Corporate Headquarters
5150 Prairie Stone Parkway
Hoffman Estates, IL 60192-3707
Telephone (847) 645-3600
Facsimile (847) 645-6201

Bosch Rexroth Corporation
Industrial Hydraulics
2315 City Line Road
Bethlehem, PA 18017-2131
Telephone (610) 694-8300
Facsimile (610) 694-8467

Bosch Rexroth Corporation
Electric Drives and Controls
5150 Prairie Stone Parkway
Hoffman Estates, IL 60192-3707
Telephone (847) 645-3600
Facsimile (847) 645-6201

Bosch Rexroth Corporation
Pneumatics
1953 Mercer Road
Lexington, KY 40511-1021
Telephone (859) 254-8031
Facsimile (859) 281-3491

Bosch Rexroth Corporation
Mobile Hydraulics
1700 Old Mansfield Road
Wooster, OH 44691-0394
Telephone (330) 263-3300
Facsimile (330) 263-3333