

EasyHandling – More Than Just a Kit of Components

Easier, faster, more economical



The perfect system solution for every application

Efficient production processes are the key to your success in the marketplace. Today's environment, defined by rapid change and short product cycles, demands flexible systems with an optimal design and configuration. EasyHandling gives you the tools you need to automate your handling applications with greater ease, speed, and efficiency. EasyHandling is more than just a modular collection of mechanical components; it takes an evolutionary step forward by providing an all-inclusive system solution – our best solution for your requirements.



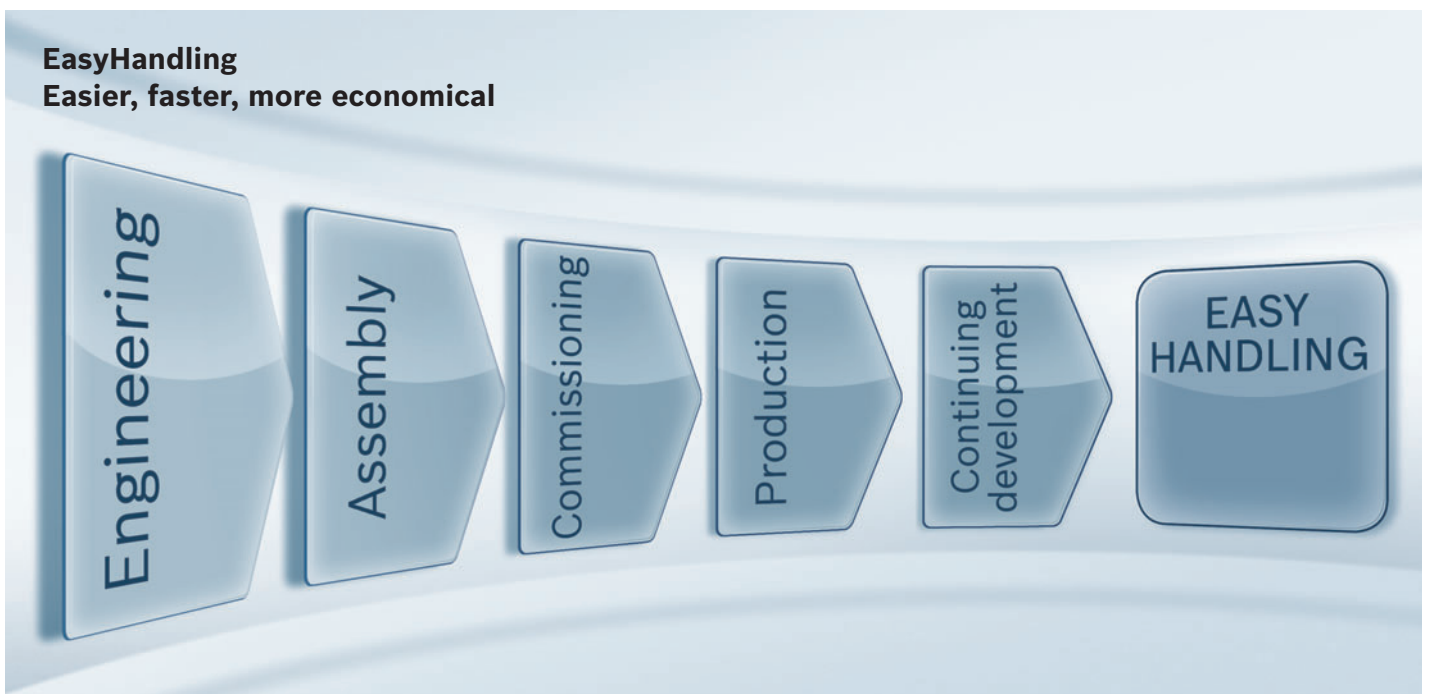

Easier customization

EasyHandling facilitates the process of creating customized solutions and provides targeted assistance at each step along the way. Get real solutions in next to no time – with consistent support.

Faster optimization

EasyHandling offers flexible scaling, allowing you to quickly and easily adjust to future requirements – an intelligent principle with built-in foresight.

More economical through unparalleled efficiency

EasyHandling enables a highly efficient use of resources for all phases and components. The system is consistently configured to optimize your processes – from planning to operation and even further development. Define your own technical edge.

By integrating EasyHandling in your entire process chain, your benefits are not limited to a unique system solution. The perfect interaction of all drive and control technologies, standardized interfaces, and the intelligent start-up assistant significantly reduces your planning, installation, and start-up times:

- ▶ Make your **planning** up to 70% faster
- ▶ Reduce your **installation** times by up to 60%
- ▶ Cut your **start-up** times by up to 90%
- ▶ Make your **production** more efficient, and thus more profitable, on the whole.
- ▶ Make a reliable investment in the future with our well-designed **product enhancements** and ongoing technological improvements.

EasyHandling – more than just a kit of components

The modular system that's made for more

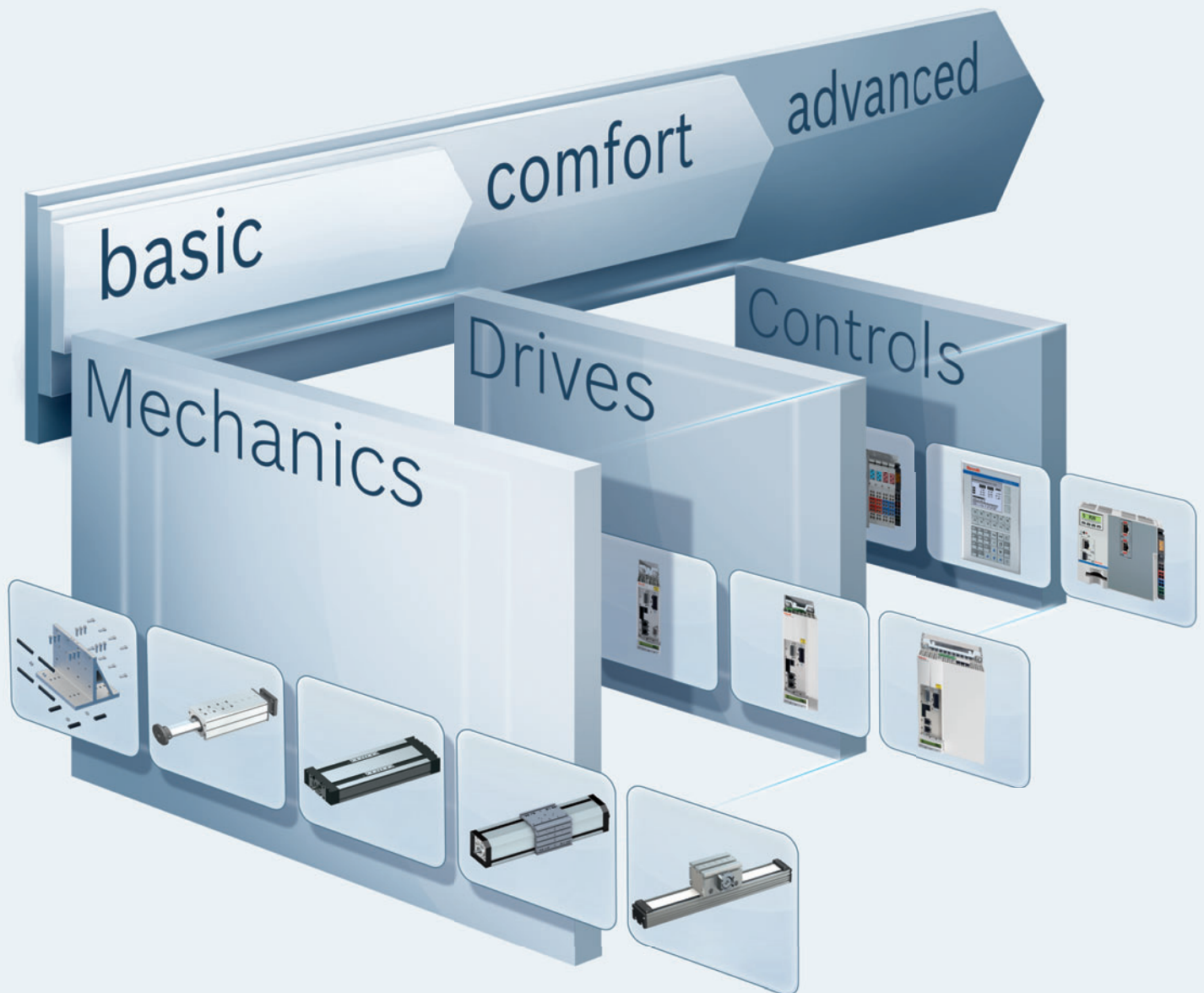



basic – made-to-measure mechanics

EasyHandling “basic” includes all mechatronic components for complete, customer-specific **single and multi-axis linear motion systems**.

Thanks to consistently designed, standardized interfaces, combining components has never been easier. Practical tools and aids help you select and configure your solutions.

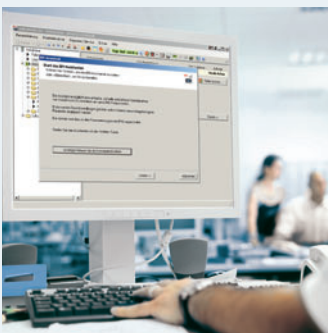

comfort – getting started even faster

EasyHandling “comfort” expands the basic component range by adding **powerful servo drives with multi-protocol support**. Intelligent universal control units are the ideal match for a wide variety of handling applications.

It also features the uniquely convenient **start-up assistant EasyWizard**. Generate ready-to-use linear motion systems after entering just a few application-specific details.



advanced – for complete control

With its **individually scalable, high-performance motion logic solution**, EasyHandling “advanced” makes configuration and handling even easier. Predefined functions covering more than 90% of all handling applications eliminate the need for time-consuming programming.



EasyHandling basic – example applications

The EasyHandling modular system provides a comprehensive portfolio of standardized, configurable products as the foundation for tailor-made mechatronic handling applications – from individual components to complete handling systems. You get a customized solution based on your requirements: as single components, combined as a kit, partially or fully assembled.

The following pages contain the most common geometric configurations, which are available under the designations listed here:

- ▶ Single-axis
- ▶ Pick & place
- ▶ Linear gantry
- ▶ X-Y table
- ▶ Cantilever gantry
- ▶ XXYZ gantry

Our engineering experts are always available to assist you with additional customized solutions.

**Mechatronic
system solution**

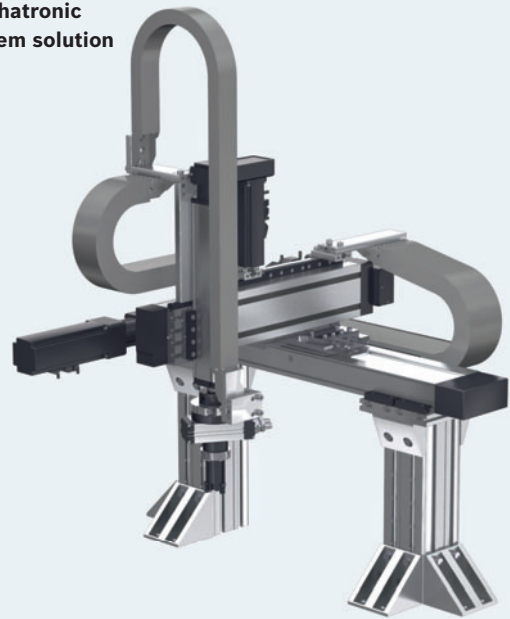

Single-axis



Single-axis



Pick & place

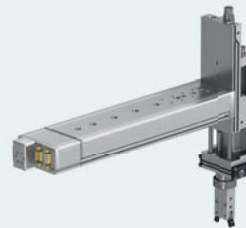

Linear gantry



X-Y table



Cantilever gantry



**XXYZ gantry with
connection shaft**



**XXYZ gantry with
synchronized motors**



EasyHandling basic – components



Gripping and rotating

This fine-tuned range of products can be ideally combined with the modular system. The additional components perform functions such as mechanical and suction gripping:

- ▶ Rotary modules
- ▶ Mechanical grippers
- ▶ Vacuum technology
- ▶ Single valves



Linear axes

Rexroth offers a comprehensive range of configurable linear motion systems, with variable lengths as well as numerous designs and sizes:

- ▶ Attachment for Rexroth or 3rd party motor
- ▶ Lengths up to 12 m
- ▶ Speeds up to 10 m/s
- ▶ Repeatability up to ± 0.005 mm



Servo motors

The IndraDyn S range offers you a comprehensive selection of servo motors that deliver convincing performance, no matter which of the many designs, versions, options, and power ratings you choose – the optimal solution for the EasyHandling system.

- ▶ Maximum torques up to 43.5 Nm
- ▶ Maximum speeds up to 9000 rpm
- ▶ Multi-turn absolute encoder
- ▶ Electrically released holding brake (optional)



Connection technologies

For versatile combination options and the construction of complete solutions, Rexroth offers a wide range of perfectly matched, intelligently designed connection elements:

- ▶ Brackets, adapter plates, sliding blocks, and clamping elements
- ▶ Power cable chains, guide channels, and clamping profiles
- ▶ Strut profiles and feet

EasyHandling comfort – example applications

Compact drive variants

Rexroth offers a wide range of electric drives to operate one or two electro-mechanical axes with a mechanical connection shaft. These can be combined with a variety of drive options.

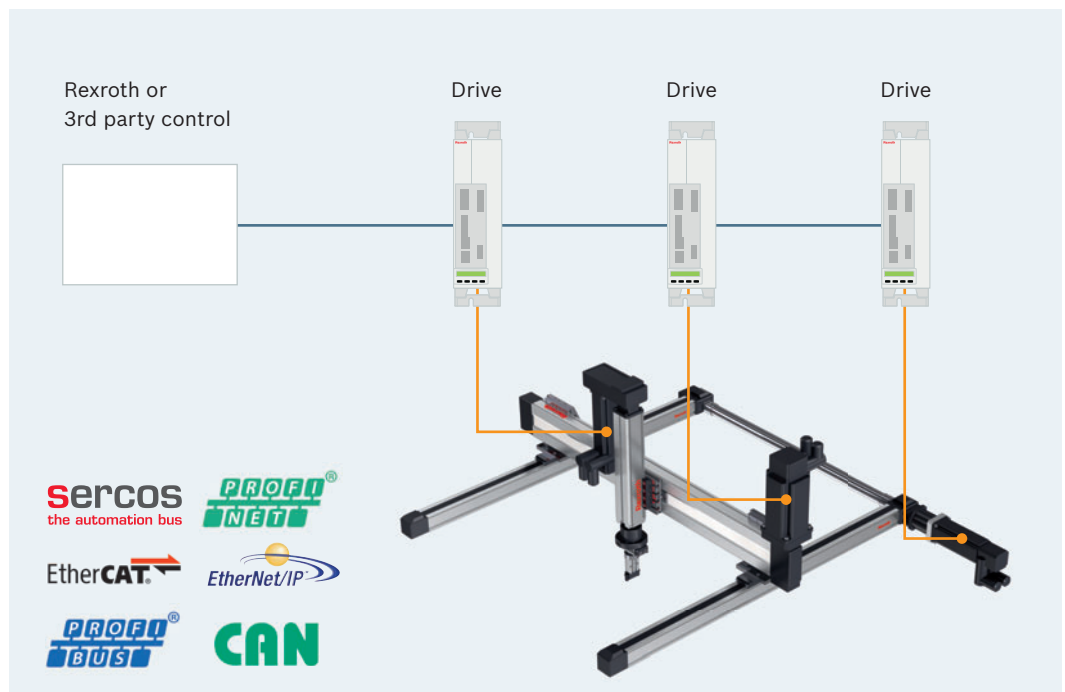

Rexroth-specific drive variant

With “cross communication”, we provide master-slave operation as a smart solution for two synchronized electromechanical axes. This enables better dynamics, since the overall mass inertia is distributed over two drives, and ensures fewer interfering contours and design limitations.

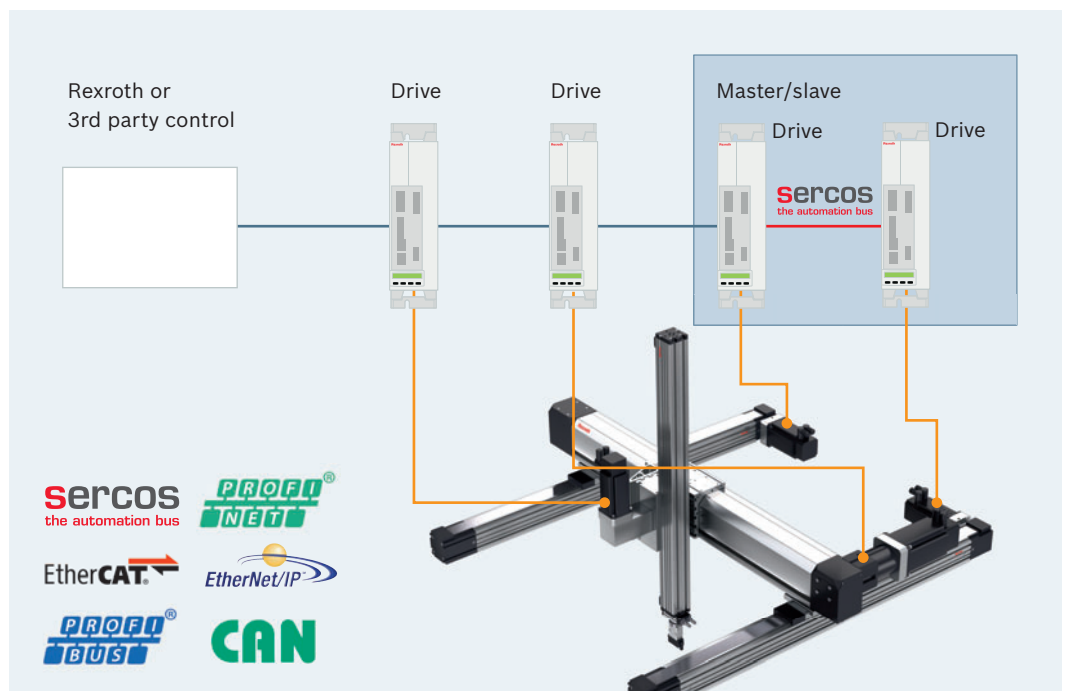

EasyHandling comfort – components



Drives

IndraDrive Cs electric drives stand out especially for their space-saving design, excellent performance data, and finely graded size increments. Since they also have outstanding control loop characteristics, they are ideal for mechatronic handling applications. With their broad range of Ethernet-based interface options for control communication and their multi-encoder interface, they offer an open architecture and the greatest possible flexibility:

- ▶ Direct mains connection to 110-230 V AC or 200-500 V AC
- ▶ Power range from 100 W to 14 kW
- ▶ Interfaces: sercos III, PROFINET IO, EtherNet/IP, EtherCAT, PROFIBUS DP, CANopen, etc.
- ▶ Drive-based motion logic (optional)
- ▶ Drive-based safety technology (optional)



Drive-based safety technology

The safety of machinery and equipment is to a large extent determined by the extent of dangerous movements originated by the machine.

Safety On Board from Rexroth makes it easier to create safe machine concepts while minimizing downtime.

Rexroth safety technology is integrated in the drive and monitors the movements precisely where they occur.

The result: extremely fast response times when internal controls are triggered.

EasyHandling advanced – example applications

Drive-based control version

The drive-based control is ideal for small stand-alone applications with up to 6 axes. Because the control function is integrated in the drive, it presents an economical, compact variant over other commercially available control architectures.



Controller-based control version

The controller-based control variant is ideal for handling applications with up to 4 kinematics configurations and up to 6 axes per configuration.

You can choose to create your turnkey visualization project for a Rexroth HMI or an Android device, which provides greater flexibility in implementing the operating concept.

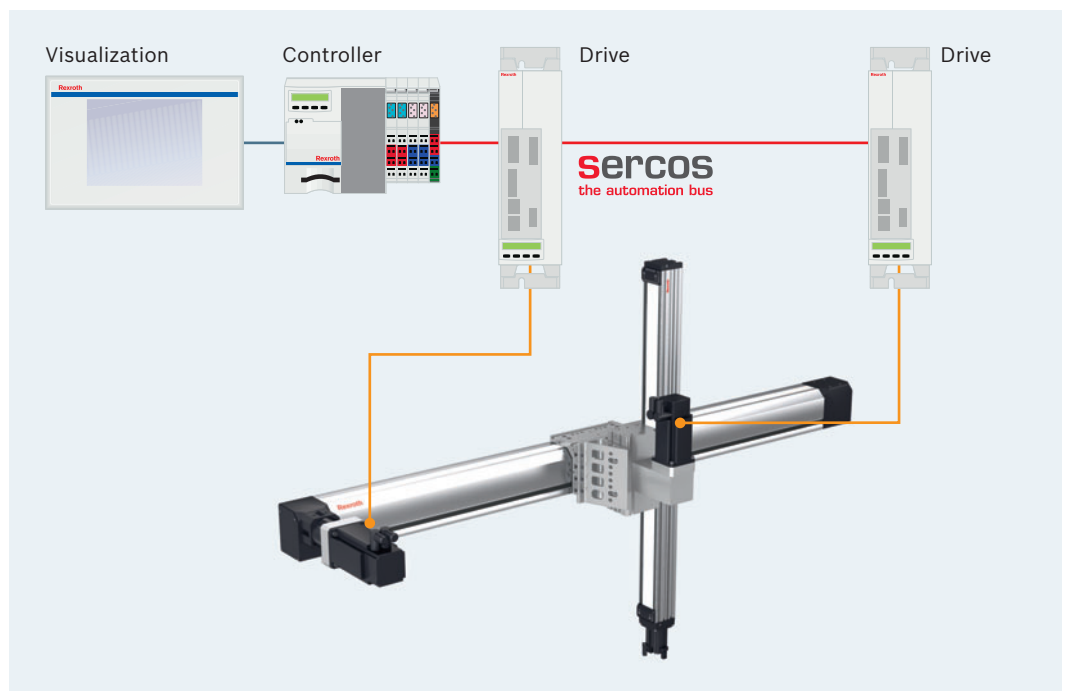

EasyHandling advanced – components



Controls

The controller-based IndraControl L control platform from Rexroth is distinguished by its open communication capability, compact design, and variable power range. The core unit with terminals is simply mounted on a hat rail without the need for tools. With add-on function modules, I/O modules and a choice of different communication interfaces, the controllers can be tailored to each specific application.

- ▶ Scalable: processor, memory, interfaces, I/O, function modules, etc.
- ▶ Program organization: IEC 61131-3
- ▶ Programming languages: SFC, ST, IL, LD, FBD, CFC



I/O technology

Rexroth I/O technology ensures reliable and safe integration of sensors and actuators, no matter where they are located – locally in a control cabinet or distributed.

- ▶ IP20 variant: added directly to the control unit or linked via a bus coupler
- ▶ IP67 variant: linked via a bus coupler for status monitoring close to axes



Visualization

Rexroth's IndraControl V range offers a comprehensive HMI system range for individual control, operation, and visualization in all industries. The scalable range includes

- ▶ Controller-based compact operator panels
- ▶ Manual operator panels for mobile use
- ▶ Embedded-PC-based operator panels

EasyHandling process optimization

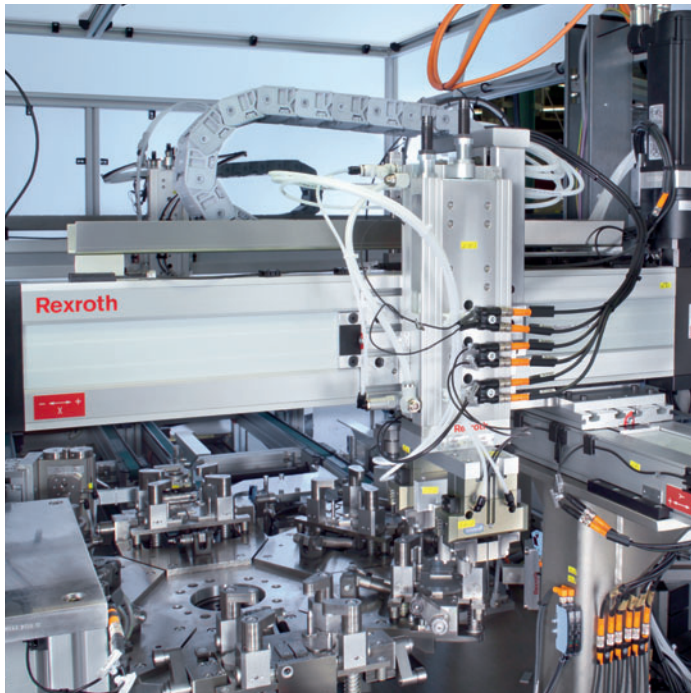

With EasyHandling, you have optimal control over your process sequence, with efficiency as a central feature. From planning, assembly, and commissioning up to regular production and future-proof further development.

Engineering – up to 70% faster

EasyHandling tools support you as early as the component selection stage – with suggested solutions that include information on parts lists, technical data, and CAD drawings.

Assembly – up to 60% faster

Thanks to form-fit connection technology, all mechanical components are perfectly aligned and accurately connected right away.

Commissioning – up to 90% less effort

The intelligent start-up assistant EasyWizard takes the hassle out of parameter input and configuration. Your handling system is ready to go with just a few clicks.

Production – more economical and efficient

Rexroth supports effectiveness with a series of smart tools: drive controller software provides maintenance information based on runtime and travel to help operators comply with service intervals. The result: longer service lives, calculated downtimes, and lower failure rates.

Continuing development – continuous improvement

Already equipped for future market developments: the consistently open architecture makes EasyHandling systems a convincing choice. Flexible mechanical or electrical components can be quickly and efficiently adapted to respond to new production requirements.

Engineering – with the latest software support

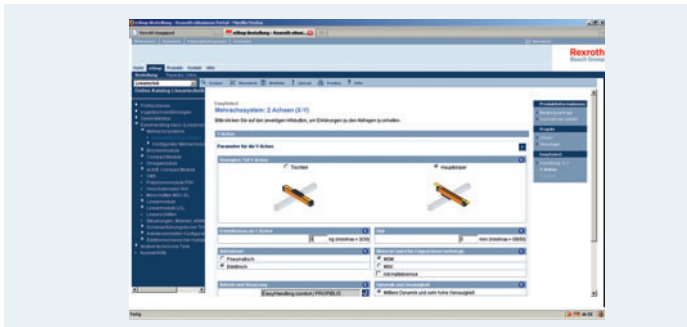

Selection guide

With the “EasySelect” selection guide, you receive a customized proposal for a single-axis or multi-axis system after entering just a few key parameters. This proposal can be used as the basis for further planning or to request a consultation.

► www.boschrexroth.com/easyselect

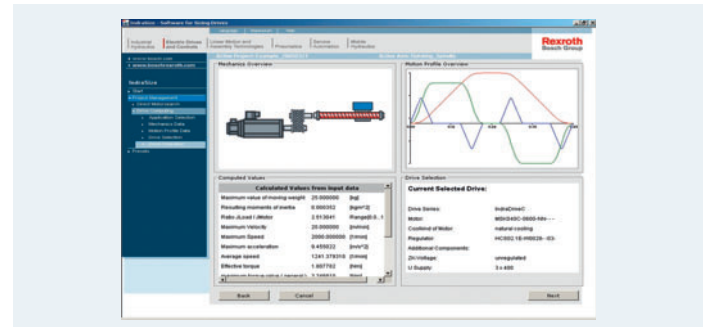

Drive sizing

IndraSize software makes it easier to calculate the optimum sizes of drive controllers, motors, and mechanical transmissions.

► www.boschrexroth.com/indrasize

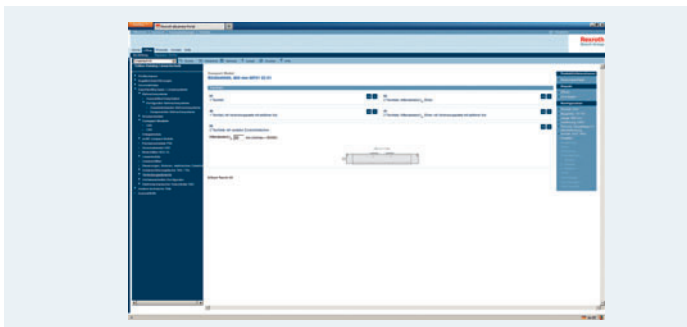

Single-axis configurators (CAD and eShop)

Single-axis configurators can be used to calculate your own custom linear motion system in next to no time. The results can be generated as downloadable 2D or 3D CAD files in common formats. You can proceed to order your configured linear motion system directly through the eShop.

► www.boschrexroth.com/easycad

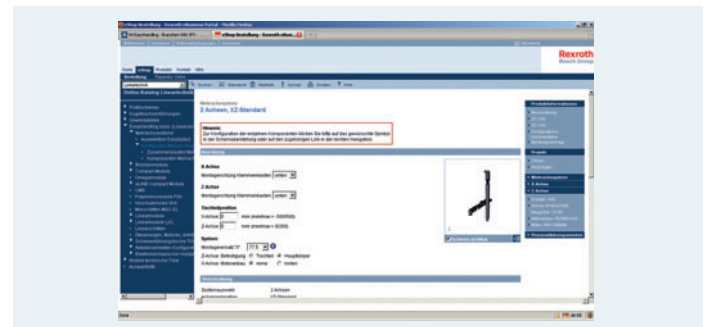

Multi-axis configurator (CAD)

The multi-axis configurator helps you quickly calculate your specific handling system. The results can be generated as downloadable 2D or 3D CAD files in common formats.

► www.boschrexroth.com/easycad

Assembly – perfectly matched components

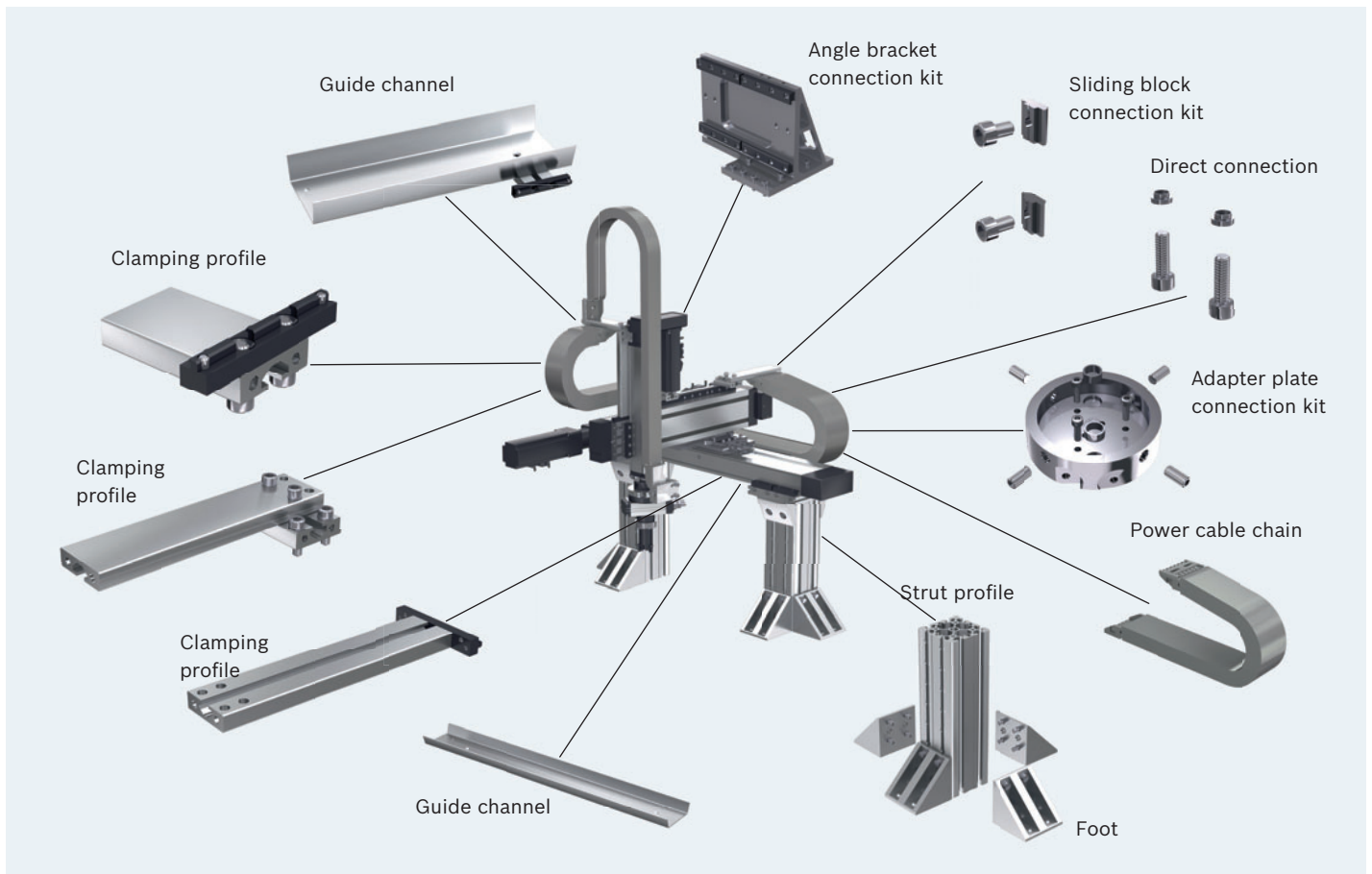

EasyHandling stands for thoroughly integrated efficiency and cost-effectiveness – also when it comes to assembly. The standardized mechanical interface “Easy-2-Combine” in combination with an extensive portfolio of connection elements, power cable chains, guide channels, and strut profiles significantly minimizes assembly effort. The innovative locating grid and centering ring technology ensures unrivalled precision and reproducibility when connecting grippers, rotary and linear motion systems. Many products can be connected to each other without the need for extra adapter plates or brackets. If additional connection elements are required for combination

of specific components, they are combined into the predefined component group.

When connecting power cable chains and guide channels, these components are attached via node points or the lateral slot on the linear motion system. Strut profiles, which are also equipped with an Easy-2-Combine interface, can be used to construct frames.

Key advantages at a glance:

- ▶ Less effort required for design and assembly
- ▶ Standardized interface concept
- ▶ Numerous combination options
- ▶ Easy reproducibility

Commissioning – bridging different technologies

Drive start-up

EasyWizard is an assistant that is integrated as a standard feature of Rexroth's engineering framework IndraWorks. It was designed to help users start-up linear systems easily, rapidly and safely. Starting up electromechanical axes often used to be a complicated, time-consuming and error-prone procedure. EasyWizard has changed all that – mechanical data from the system plates are entered in the EasyWizard to quickly align the mechanics and drive in just a few steps. Starting up linear motion systems has never been easier.

► www.boschrexroth.com/easywizard

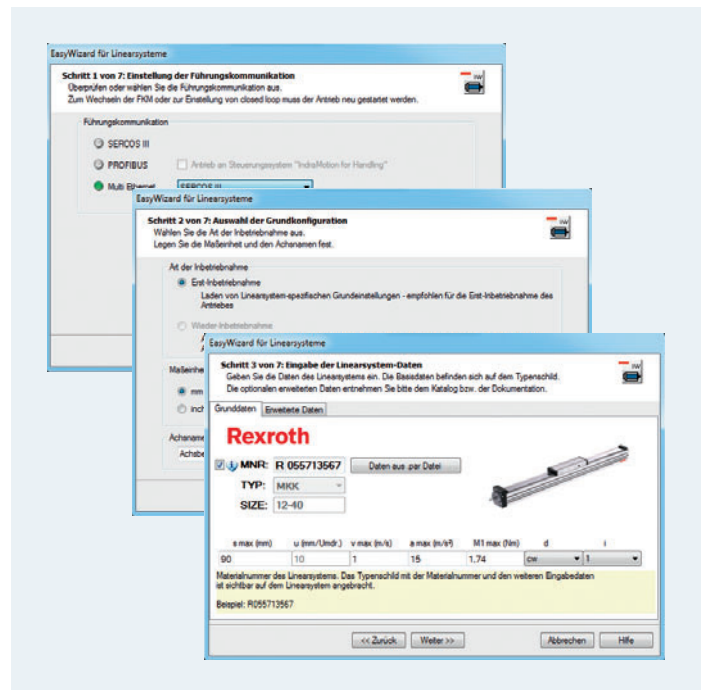

Control solution

IndraMotion for Handling is a preconfigured control solution for multiple applications that is integrated in the IndraWorks engineering framework. This solution allows you to implement classic Cartesian motion tasks with up to 4 kinematic configurations and up to 6 axes per configuration.

Key performance features:

- Extensive starter kit for configuration, easy parameterization of process data
- Complete PLC program and libraries with powerful commands
- Turnkey visualization projects for various HMIs
- Motion logic control with all components for actuating I/Os and drives, and for stationary and mobile visualization devices
- Fully integrated system documentation



Production – integrated functionality and process reliability



Diagnostics

IndraMotion for Handling contains a powerful diagnostic system for system and user messages. It supports information, warning, and error messages. Diagnostic messages are displayed in a text format and can refer to control and drive diagnostics as well as maintenance and user messages. The messages are clearly structured and can be distinguished by different icons and colors. They are also automatically sorted and can be filtered according to message type.



Maintenance

IndraMotion for Handling features an integrated maintenance function for linear motion systems, which enables the recording, processing, and display of maintenance data. Lubricants usually need to be changed at defined performance or operating intervals in order to prevent mechanical wear. The required maintenance data is read out from the drive. The control calculates the maintenance intervals and regularly updates maintenance data. In the HMIs, this data is sorted in a clear overview and displayed in numerical format or as color-coded bars. When pre-set, adjustable thresholds are reached, warnings are issued before displaying error messages. Once the required maintenance has been performed and acknowledged in the system, a new cycle starts.

Continuing development – future-proof, flexible systems

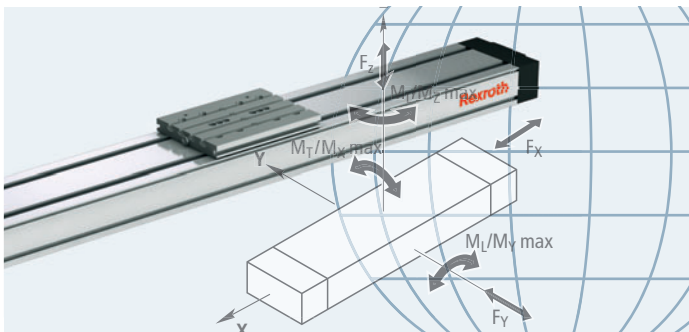

Compliant with international standards

- ▶ PLC according to IEC 61131-3
- ▶ Fieldbuses according to IEC 61158
- ▶ OPC UA
- ▶ etc.



Modular for consistently open architecture

- ▶ Flexible selection of motor attachment (for Rexroth or 3rd party motor) within EasyHandling basic
- ▶ Choice of any fieldbus (for Rexroth or 3rd party control) within EasyHandling comfort
- ▶ Choice between various turnkey visualization projects (for Rexroth HMI or Android smart device) within EasyHandling advanced

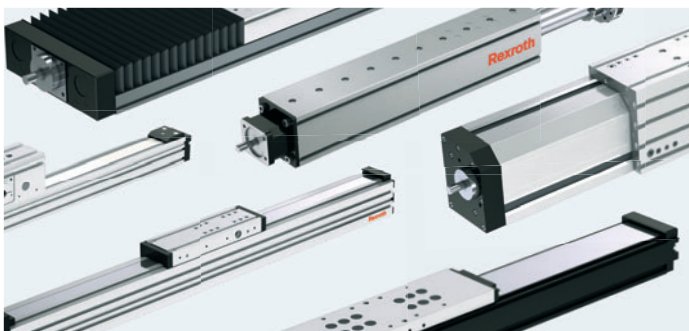

Scalable

Freely configurable mechanical and electrical components for a wide variety of application and load cases enable flexible adaptation to rapidly changing process and market requirements.

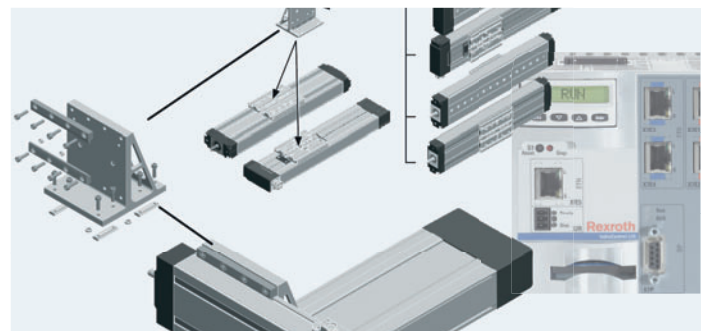

Expandable

Standardized interfaces on mechanical and electrical components enable a flexible expansion of structures and functions.

- ✓ Plan up to 70% faster
- ✓ Reduce installation times by up to 60%
- ✓ Minimize effort by up to 90%
- ✓ Increase cost-effectiveness and efficiency
- ✓ Keep improving, consistently and reliably





Ingenious solution,
80% faster engineering } Exactly

Bosch Rexroth AG

Bgm.-Dr.-Nebel-Str. 2
97803 Lohr, Germany
www.boschrexroth.com

Find your local contact person here:

www.boschrexroth.com/contact

The data specified serve only to describe the product.

As our products are constantly being further developed, no statements concerning a certain condition or suitability for a certain application can be derived from our information. The information given does not release the user from the obligation of own judgment and verification. It must be remembered that our products are subject to a natural process of wear and aging.