

Linear Motion Technology – precise, reliable, future-proof

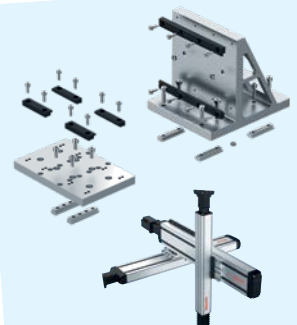

Linear Motion Technology from Rexroth – the best precondition for precision, process reliability and efficiency

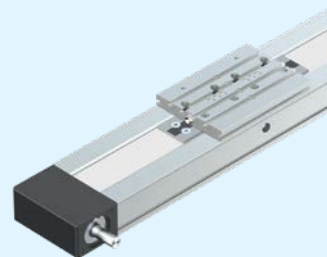

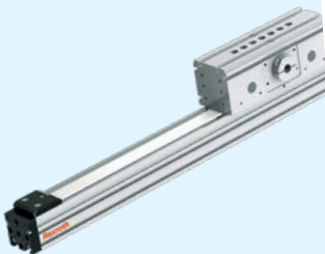
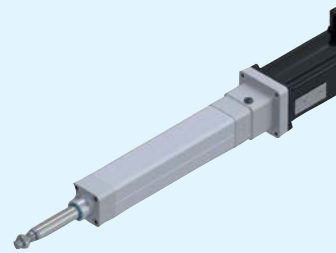
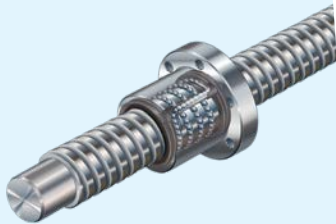
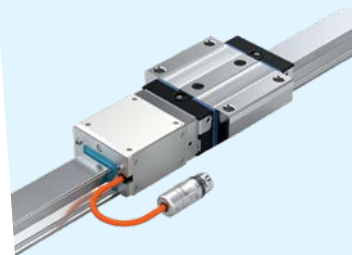
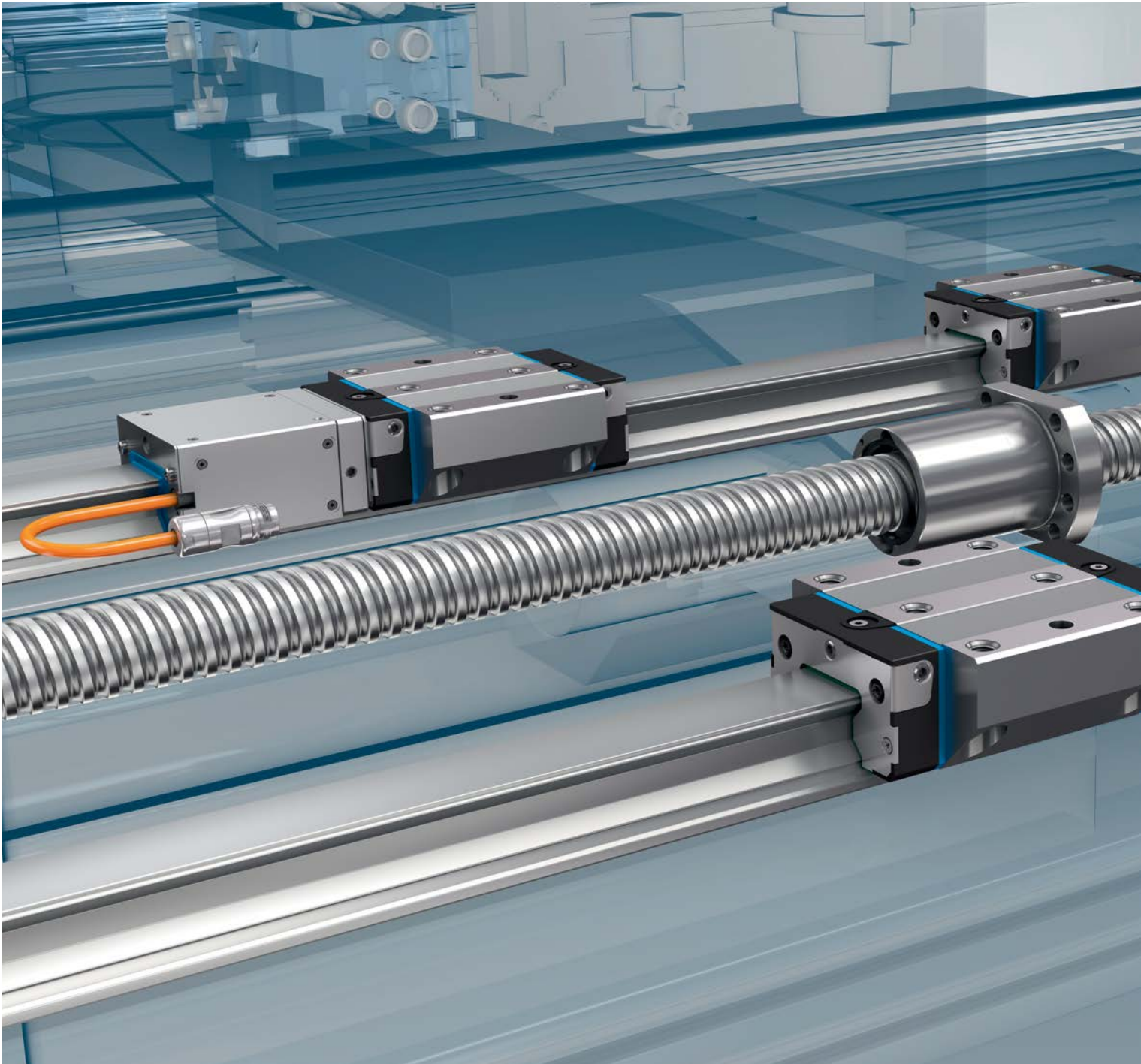
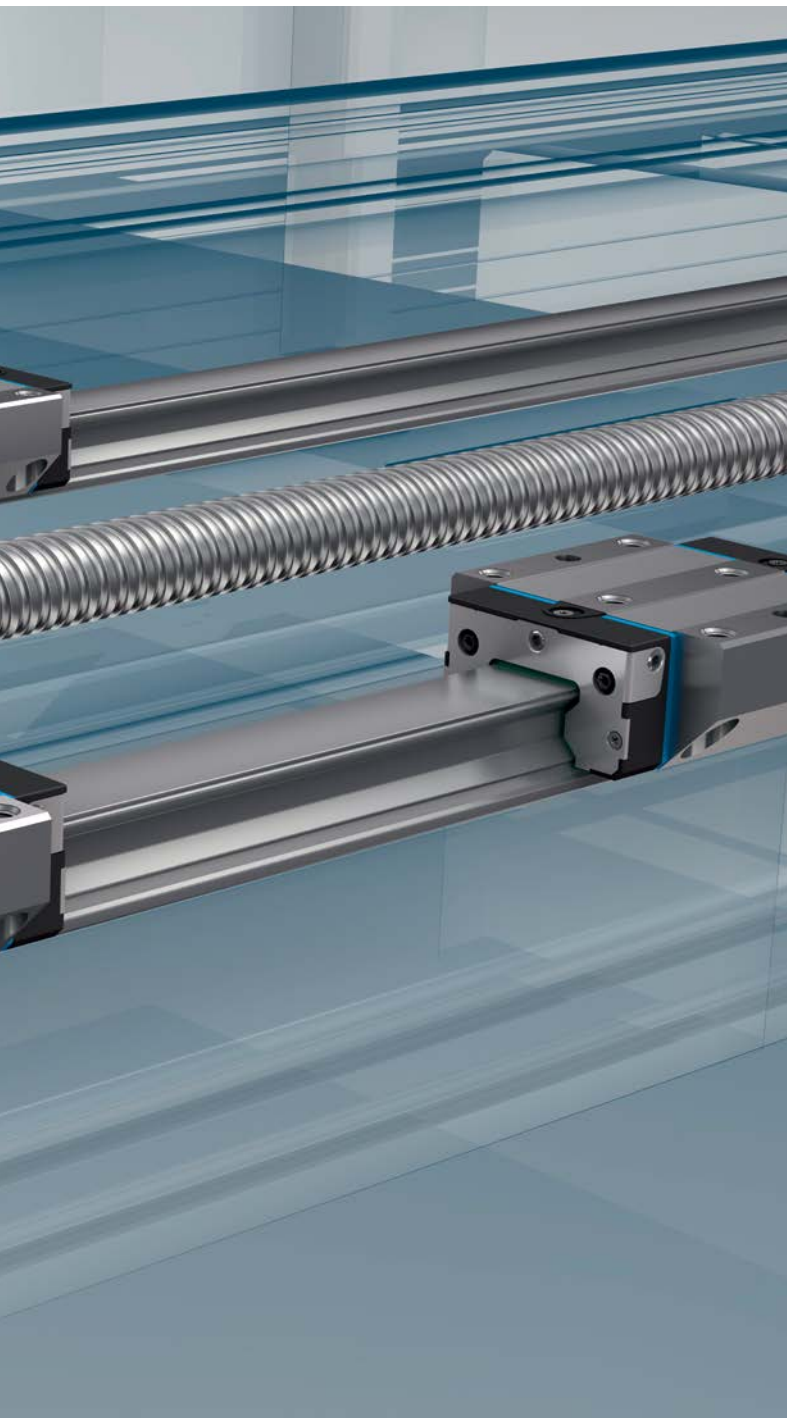

Linear Motion Technology Overview

- 04 Bosch Rexroth –
The Drive & Control Company
 - 06 Linear Motion Technology – At Home in
Many Industries
 - 08 Performance Capabilities of Linear Motion
Technology
 - 12 Perfect Handling Solutions – EasyHandling
 - 16 Energy Efficiency
 - 18 Technological Highlights and Types of
Profiled Rail Systems
-

Product Lines

- 22 Roller Rail Systems
 - 28 Ball Rail Systems
 - 36 Integrated Measuring System
 - 38 Miniature Ball Rail Systems
 - 40 Cam Roller Guides
 - 42 Linear Bushings and Shafts
 - 58 Ball Screw Drives
 - 68 Planetary Screw Assemblies
 - 70 Linear Motion Axes
 - 82 Actuators
-

Further Information

- 84 The Drive & Control Company – The Full
Product Spectrum
- 86 Your Partner for Success
- 88 Media Support, eTools
- 90 GoTo Focused Delivery Program



Helping you to scale new heights

At Rexroth, we are proud of our worldwide reputation for setting benchmarks in drive, control and motion. The key to this technological leadership is an infrastructure focused systematically on partnering with our customers and understanding your business.

This is the way we live our claim:

Bosch Rexroth – The Drive & Control Company.



With our integrated and interdisciplinary approach, we cover the complete spectrum of drive and control technologies. This scope is unparalleled in the market. Our innovative engineering delivers optimally matched systems, from standard configurations to customized high-end solutions that are open for combination with other components and systems. This assures that our customers can enjoy continuous and value-creating progress and success. Our mission is to act as providers of solutions, performance and results – and with a future-oriented energy efficiency strategy that is just as unique as our portfolio of products and services.

Motion solutions for every need

Our aim is to respond flexibly to your needs, collaborating closely with you all the way to create the perfect solution for each application. We achieve this aim thanks to the unsurpassed breadth of our portfolio with all the components needed for drive, control and motion. Backed by our superior expertise in consulting, development, implementation and service, this creates decisive competitive advantages for you. Economically, you benefit as well, since our offerings can help you to improve your productivity. This is due to the seamless interaction of all relevant technologies, from electric drives and controls to hydraulics, to linear motion and assembly technologies. Your benefit: You can count on system solutions and cross-system integrated applications with a sophistication that is unrivaled anywhere in the world.

We get industries moving anywhere in the world



Genuine 360° solutions

As a global leader in the industrial and factory automation markets and in mobile applications, Bosch Rexroth is always a technological step ahead. We offer our customers a unique breadth and depth of industry and application know-how based on decades of accumulated experience. Our experts for each industry not only know exactly which challenges our customers face, but they speak their language, too. As a result, we are able to engineer precisely the right systems and technology packages that our customers need for their applications. In addition, our technologies and solutions help you to use energy more intelligently. In terms of the overall machine life cycle – from design and build to operation and maintenance – you can tap into enormous savings potential by using Rexroth's especially energy-efficient products.

The professional approach to motion

With our broad portfolio and our solution-finding expertise we can respond flexibly to all your needs. Our thoroughly professional approach in development and application-related support, in manufacturing, sales and service, as well as our exceptional manufacturing depth and our incomparable range of components and systems can generate still more competitive advantages for you.

Benefit also from our unique capability to deliver complete plug-and-play systems from a single source because we have all the necessary technologies in-house. With our consistent standardization policy combined with the best possible customization options, we satisfy the requirements of our customers across all industries – from individual components through to perfectly equipped systems including intelligent controls and motors.

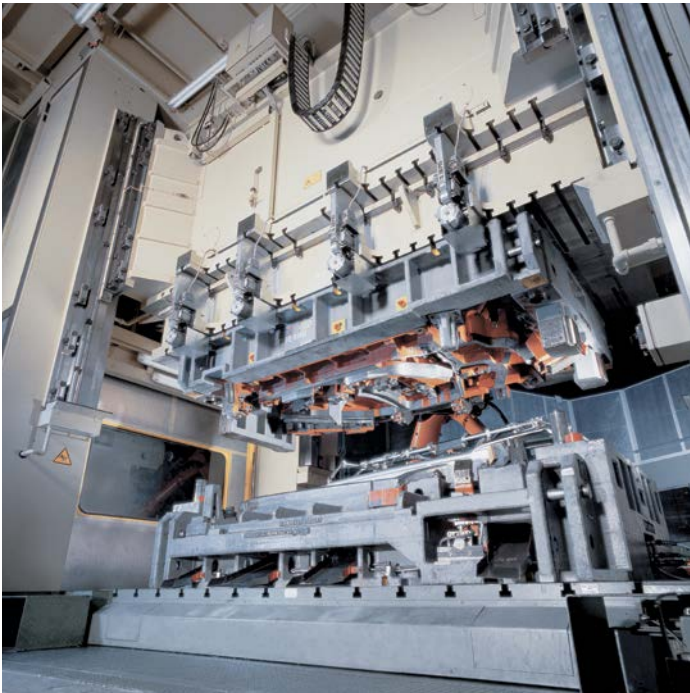

Unique industry sector know-how

As a technology leader, we are perfectly at home in any industry. Whether the application is in machine tools, wood-working, food and packaging, assembly and handling, or solar and semiconductor manufacturing, we speak your language. We cover absolutely everything, from the automotive industry to cutting machine tools.

Rexroth deals daily with technical innovations. This calls for a high degree of flexibility and the willingness to keep updating our skills and knowledge. By doing so, we make sure that our unmatched sector-specific know-how keeps pace with the state of the art, so that we can always find the optimal system solution for your needs. With modern linear motion systems and with an extensive range of assembly technology components, you can rely on receiving complete solutions that deliver top performance.

Special-purpose machinery with a technological edge

Rexroth's Linear Motion Technology is the perfect technological platform for building both mass-production and special-purpose machinery. We offer you that special combination of precision, speed, energy efficiency and production reliability. You benefit from the engineering expertise and services of a technology leader – because the aim of technical progress is always to serve our customers.

We maintain an ongoing dialog with our many customers in different industries all around the world to ensure that we know which requirements have to be met in which industry to achieve an optimal solution. As a result, we can offer you technological advances with innovative and future-oriented products that improve both the performance capability of the applications and their energy efficiency.

Your challenge is our business – putting ideas in motion

Our exceptional capabilities deliver all you want and more

Reliable guidance, precise positioning and handling, and everything that goes with them, are our core expertise. When it comes to Linear Motion Technology, there are good reasons to rely on Rexroth. With us, you benefit from a seamless range of innovative drive and control technologies, providing immense potential for smart solutions:

- ▶ Component and system know-how
- ▶ Sensitive attention to detail and precision
- ▶ Seamless cross-technology expertise
- ▶ Utmost production safety
- ▶ Vast range of products and services, unique manufacturing depth
- ▶ Complete solutions with maximum connectivity

Thanks to our leading expertise in linear motion technology, our products and solutions deliver top performance, while also offering substantial energy-saving potential. Careful use of scarce resources is, after all, one of the biggest challenges facing industry. Our quality management, designed to satisfy the highest expectations, provides the assurance of long service life, so that your investment will pay you back many times over in the future.

As a company that thinks ahead, we are also committed to minimizing environmental impacts and continuously improving energy efficiency.



Guidance

The deciding factors for high-performing Linear Motion Technology components are accuracy, dynamics and load-bearing capability in every conceivable environment and for every imaginable linear motion task. Profiled Rail Systems and Linear Bushings and Shafts are the basis for precise machine movements and machining processes of all kinds. No matter what your requirements for guidance are, we will put together the optimal solution for you from our broad range of products.

Our Linear Motion Technology products based on rolling element principles offer outstanding advantages: Compared to sliding guides, they consume up to 90% less energy. In addition, they are wear-free no matter what the load, ensuring consistent precision over their entire service life.



Drives

Ball Screw Drives are indispensable for converting rotary motion into linear motion. As mechanical drive elements they can be installed in all three axis orientations and perform movements with outstanding precision and repeatability. Our Ball Screw Drives convert the dynamics of servo motors into precise thrust motion. All of the different types and sizes have one thing in common: their exceptional performance capability.

They also score technologically in terms of energy efficiency. Since the balls recirculate, the friction losses are much lower than with Acme screw drives, resulting in zero wear and consistent precision.



Handling

Optimizing processes and improving productivity are more essential than ever today for generating that decisive competitive edge. For handling and assembly processes, efficient linear motion and multi-axis systems offer an economical and powerful automation solution. Our coordinated and modular designs allow you to implement flexible systems with minimal planning outlay. Handling processes are accelerated and employees are relieved of physical exertion and monotony.

Regarding configuration, building and starting up of machines and equipment, our complete systems save you precious time while offering unbeatable precision.

Perfect interfaces between stationary and moving machine parts

Guidance

In our vast range of guidance components you will find first-class products that will help you to build machines and equipment with a clear edge in technical performance.

All the stated load ratings are regularly confirmed in sophisticated tests. We also run repeated endurance tests to check the quality of our products – so that you can count on the reliability of Rexroth components at all times.



◀ **Roller Rail Systems**

The performance capability of Roller Rail Systems is at the very top of the range. Designed for utmost rigidity, they are especially suited for high-performance machine tools.

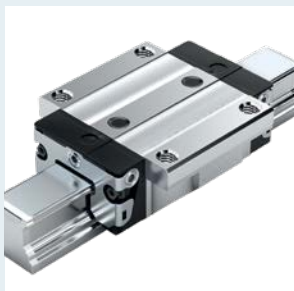

◀ **Ball Rail Systems**

A complete system for linear guides with balls as the bearing elements, characterized by high load capacities and excellent rigidity in all accuracy classes.

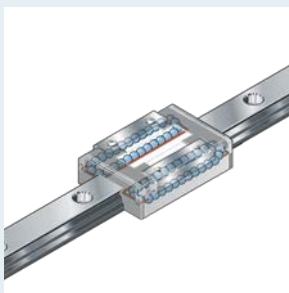

◀ **Miniature Ball Rail Systems**

The miniature versions of Ball Rail Systems are primarily used for highly precise applications in the medical and automation sectors as well as in the electrical industry.

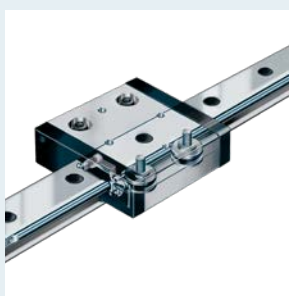

◀ **Cam Roller Guides**

Cam Roller Guides from Rexroth excel in terms of high speed, compact design, low weight, minimal friction, and low-noise operation.

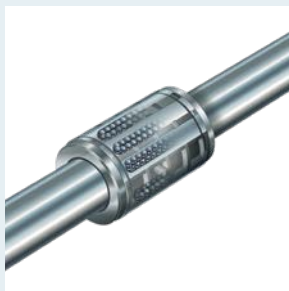

◀ **Linear Bushings and Shafts**

This product line provides amazing diversity. More than 1000 different types and variants allow limitless combination options to meet different needs and conditions of use.

Drives

High-performance components from Rexroth allow you to carry out precise, smooth movements even under high-load conditions. Our mechanical drives can be combined with Ball Screw Drives and Planetary Screw Assemblies for ready-to-install systems. Together with a motor and a control unit, complete drive systems are realized that quickly and easily meet all motion requirements.



◀ **Ball Screw Drives**

A broad selection of different types and accessories covers all requirements in terms of thrust, positioning and transport. High accuracy and high speed are the characterizing features of these products.



◀ **Planetary Screw Assemblies**

We offer perfectly coordinated Planetary Screw Assemblies for exacting feed and positioning tasks. These assemblies are characterized by their ultra-high level of precision and thrust force.



◀ **Drive Units**

Ready-to-install, complete Drive Units make installation easier.

Handling

Solving your handling challenges is one of our special talents: We develop individual and complete single-axis or multi-axis systems for you. But that's not all you can expect. We deliver them as fully assembled and pre-parameterized systems, which vastly reduces the design, installation and start-up effort at your end. Nor do you have to worry about the technical infrastructure, such as motors or control units – there is no handling challenge that we can't solve.



◀ **Linear Motion Axes** **Our Linear Motion Axes contain high-quality guidance and drive elements.**

Combined with a matching motor and control unit, they can be delivered as fully pre-configured linear motion systems.



◀ **Actuators**

The mechanical system of our electromechanical cylinders is based on proven screw drive technology. An array of motor mounting options and a range of servo motors allow for total system configuration.

The perfect system solution for every application

Efficient production processes are the key to your success in the marketplace. Today's environment, defined by rapid change and short product cycles, demands flexible systems with an optimal design and configuration. EasyHandling gives you the tools you need to automate your handling applications with greater ease, speed, and efficiency. EasyHandling is more than just a modular collection of mechanical components; it takes an evolutionary step forward by providing an all-inclusive system solution – our best solution for your requirements.



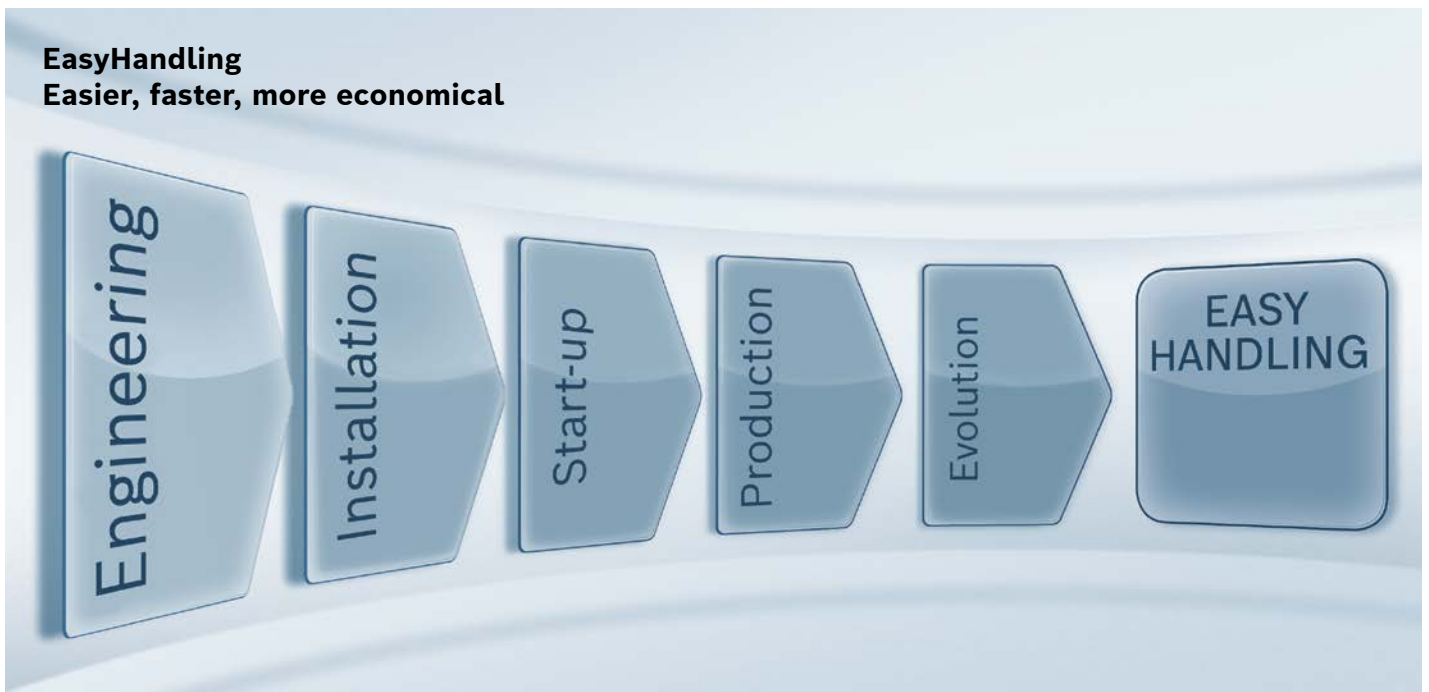

Easier customization

EasyHandling facilitates the process of creating customized solutions and provides targeted assistance at each step along the way. Get real solutions in next to no time – with consistent support.

Faster optimization

EasyHandling offers flexible scaling, allowing you to quickly and easily adjust to future requirements – an intelligent principle with built-in foresight.

More economical through unparalleled efficiency

EasyHandling enables a highly efficient use of resources for all phases and components. The system is consistently configured to optimize your processes – from planning to operation and even further development. Define your own technical edge.

By integrating EasyHandling in your entire process chain, your benefits are not limited to a unique system solution. The perfect interaction of all drive and control technologies, standardized interfaces, and the intelligent start-up assistant significantly reduces your planning, installation, and start-up times:

- ▶ Make your **planning** up to 70% faster
- ▶ Reduce your **installation** times by up to 60%
- ▶ Cut your **start-up** times by up to 90%
- ▶ Make your **production** more efficient, and thus more profitable, on the whole.
- ▶ Make a reliable investment in the future with our well-designed **product enhancements** and ongoing technological improvements.

EasyHandling – more than just a kit of components

The modular system concept
that ideally builds on itself

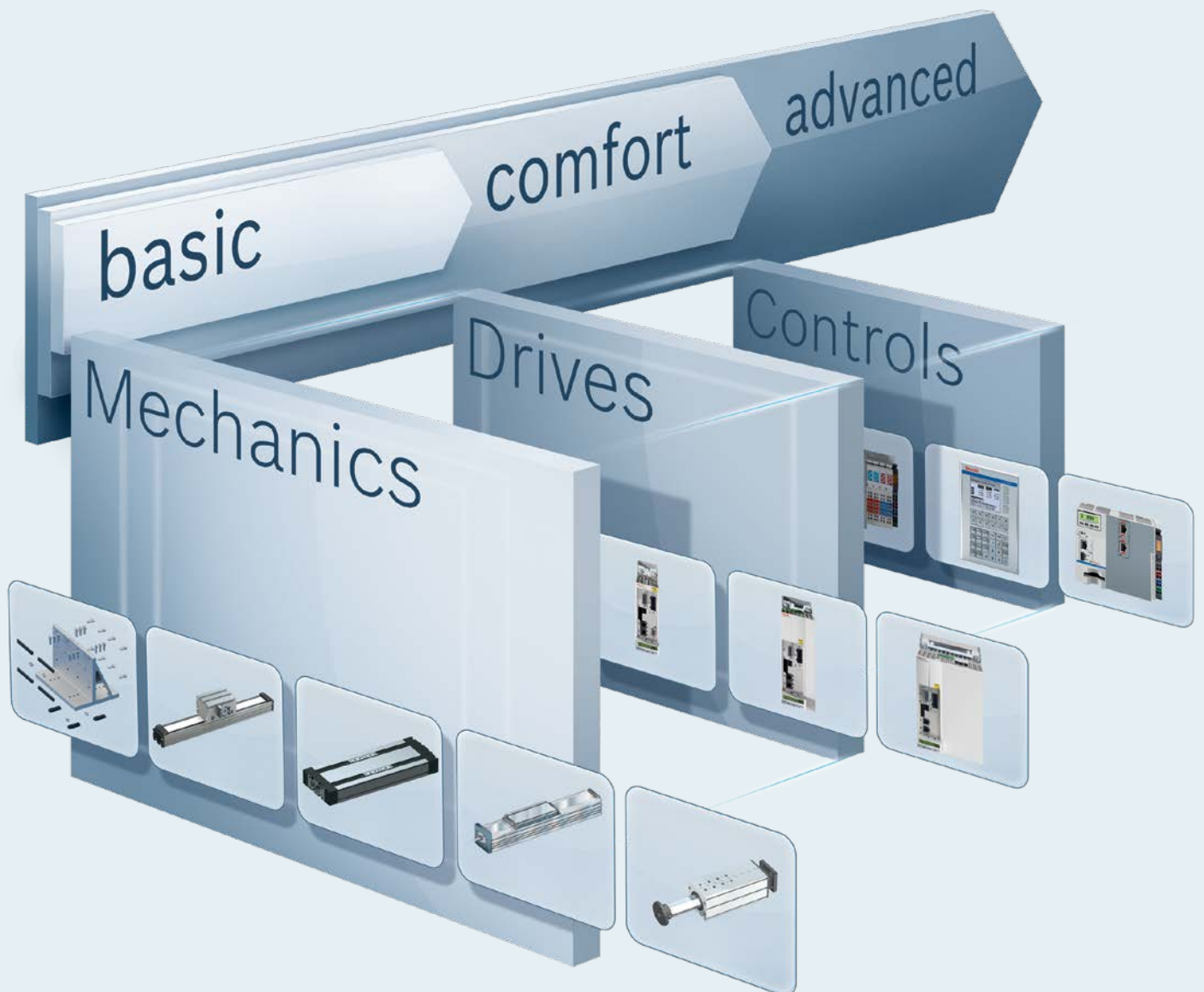

basic – Made-to-measure mechanics

EasyHandling basic contains all the mechatronic components you need to build complete, **single- or multiple-axis systems** to match your individual needs. All of the component interfaces are systematically standardized, making it possible to combine them at will. Practical tools and aids make selection and configuration even easier.



comfort – Getting started even faster

EasyHandling comfort expands the Basic component range by adding **powerful servo drives with multiple protocol capability**. The universal, smart control units are ideally suited for a variety of handling tasks.

Unique: with the **EasyWizard start-up assistant**, linear systems are ready to use after entering just a few product-specific parameters.

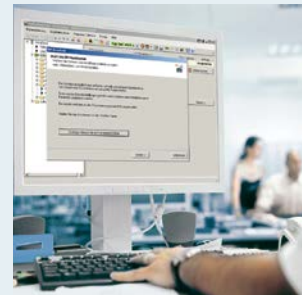

advanced –

Controls for demanding requirements

With the **freely scalable, high-performing motion logic control system**, EasyHandling advanced makes configuration and handling even easier. Predefined functions covering more than 90 percent of all handling applications eliminate the need for lengthy programming.

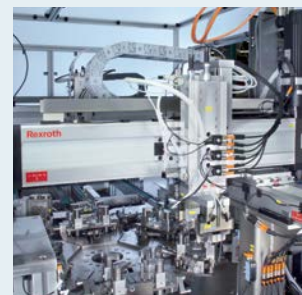

Rexroth for energy efficiency



Competency across all technologies

You can optimize your energy efficiency in all phases of the machine life cycle. Isolated individual measures implemented in complex systems typically lead to only minimal success.

Rexroth understands your requirements and knows how you can leverage the potential of all technologies.

Whether it be electrics, hydraulics mechanics, individual components, or integrated solutions, our decades of experience make us experts in a wide range of complex dynamics. Our 4EE systematic approach helps you identify and exploit all areas in which energy can be saved, from design to updating.

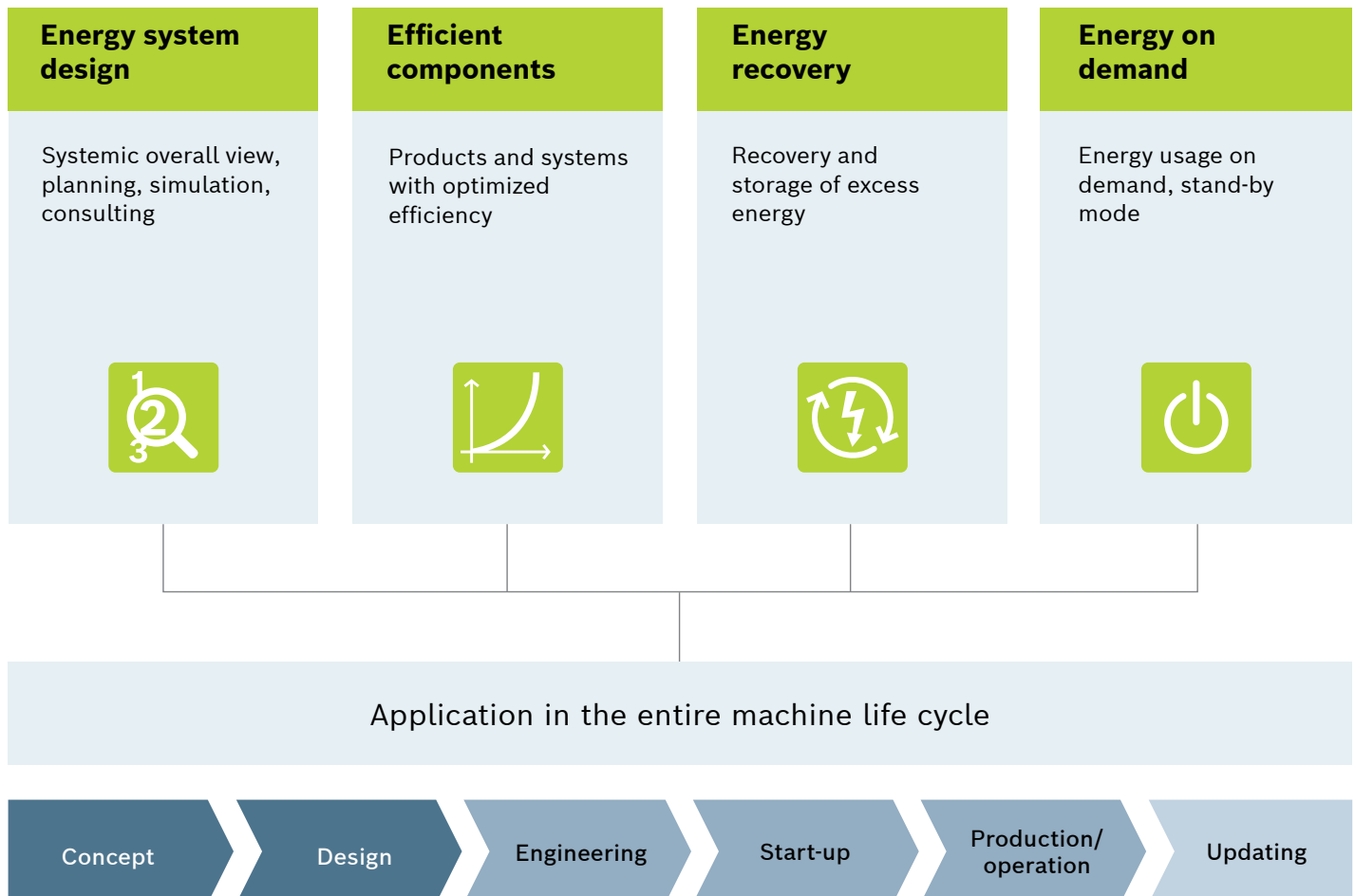

Each stage of the machine life cycle presents different opportunities for implementing energy-efficiency measures.

Minimizing energy requirements in a press with Roller Rail Systems

Application with sliding guides

Application with Roller Rail Systems

Energy requirements with sliding guides

Energy requirements with roller rail systems

90% lower friction losses in the linear guides, with a resulting drop in energy requirements (compared to sliding guides)

Higher energy efficiency due to much less friction loss
 Our rolling-element components significantly reduce the required drive energy. Compared with sliding guides, the friction can be reduced by up to 90% in applications with heavy loads, while Ball Screw Drives reduce friction by up to 80% relative to Acme screws. Mechanical efficiency can also be substantially improved by replacing fluidic drives with electromechanical drives.

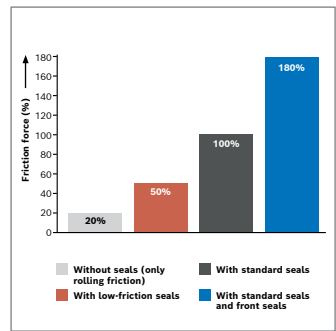

Low-friction seals cut the friction in half
 In applications with low environmental contamination levels, low-friction seals can significantly reduce the drive power requirement.

Electromechanical and fluidic cylinders
 Rexroth offers all technologies to maximize energy efficiency opportunities and provides technology-neutral consulting to find the optimal solution for each specific application.

Profiled Rail System technology highlights

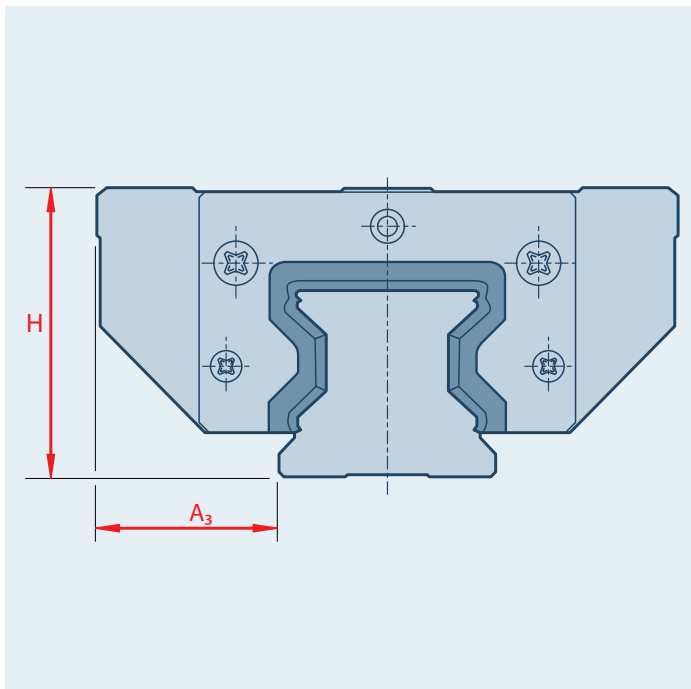
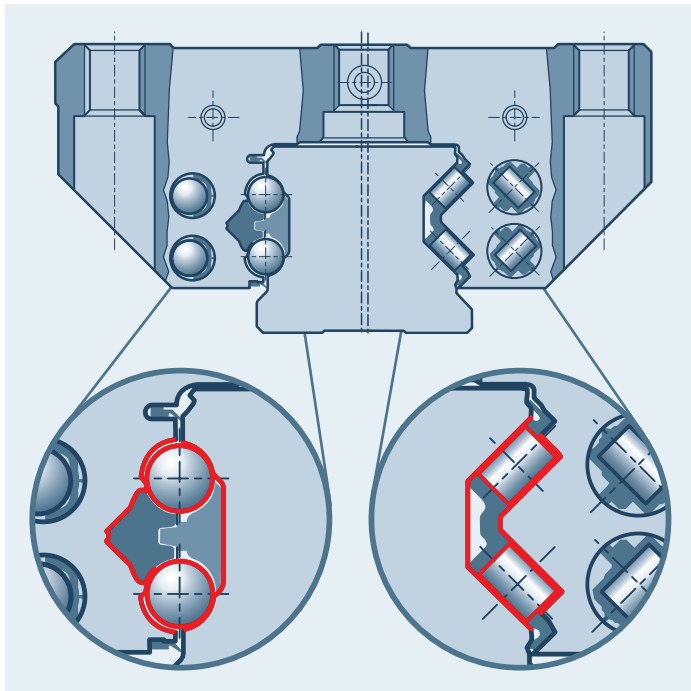

Maximum cost-efficiency in logistics and installation

Total cost of ownership is one of the key performance indicators in modern business management. To offer you the utmost in flexibility and efficiency, we manufacture our products according to a unique design principle:

interchangeability.

This is where the “inner values” count most. The rolling element sets, the raceways in the Runner Blocks and Guide Rails are manufactured to such a high degree of standardization and precision that each element can be replaced by another, regardless of the type, without any problems. This is also an essential condition for easy combinability.

The tolerances for reference edges are graded in different accuracy classes. Your requirements determine which of these will be most appropriate.

A patented entry zone helps increase travel accuracy by up to a factor of six. You also benefit from much more consistent friction. And we're the only ones who can offer open interchangeability of Runner Blocks and Guide Rails across accuracy classes. Each component, i.e., Runner Block or Guide Rail, can be ordered separately in any accuracy class and type – which saves an immense amount of time and money in terms of logistics, installation and service.

Combining Runner Blocks and Guide Rails in a Roller Rail System (taken from catalog information)

Accuracy class		Rail class				
Block class	Dimensional tolerances	H µm	P µm	SP µm	GP µm	UP µm
H	Tolerance, dimension H	±40	±24	±15	–	±11
	Tolerance, dimension A ₃	±20	±14	±12	–	±11
	Max. difference, dimensions H and A ₃ on a rail system	15	15	15	–	15
P	Tolerance, dimension H	±36	±20	±11	–	±7
	Tolerance, dimension A ₃	±16	±10	±8	–	±7
	Max. difference, dimensions H and A ₃ on a rail system	7	7	7	–	7
SP	Tolerance, dimension H	±35	±19	±10	±5	±6
	Tolerance, dimension A ₃	±15	±9	±7	±7	±6
	Max. difference, dimensions H and A ₃ on a rail system	5	5	5	5	5
UP	Tolerance, dimension H	±34	±18	±9	±4	±5
	Tolerance, dimension A ₃	±14	±8	±6	±6	±5
	Max. difference, dimensions H and A ₃ on a rail system	3	3	3	3	3

Standard Runner Blocks

- ▶ FNS
- ▶ SNS
- ▶ SNH
- ▶ FLS
- ▶ SLS
- ▶ SLH
- ▶ FKS
- ▶ SKS
- ▶ FNN
- ▶ SNN
- ▶ FKN
- ▶ SKN
- ▶ BNS
- ▶ CNS
- ▶ FXS

Standard Runner Blocks can be combined into a complete unit with ...

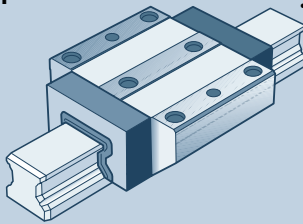

...Guide Rails with the following equipment

Standard Guide Rails

- ▶ with cover strip
- ▶ with cover strip and aluminum or plastic strip clamps

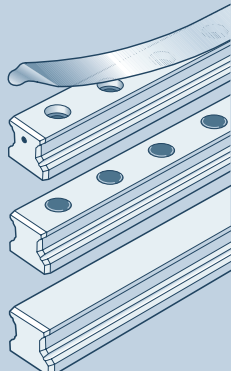

V-Guide Rails

- ▶ with plastic or steel caps
- ▶ for mounting from below

The key factor for flexibility

Precision is one of the factors that have made us a leader in Linear Motion Technology. It enables us to offer you unbeatable advantages in planning, logistics, installation and service that help you to achieve a clear competitive edge.

Combinability is a standard feature in all of our products, no matter which type you choose. Thanks to precision manufacturing (interchangeability principle) and the fully compatible range of accuracy classes, you can combine any Runner Block with any Guide Rail of the same technology and size. It would be hard to find a similar recipe for maximum flexibility anywhere in the market. Take advantage of this to solve the most demanding and diverse motion challenges in machine tools, industrial robots or general machinery construction.

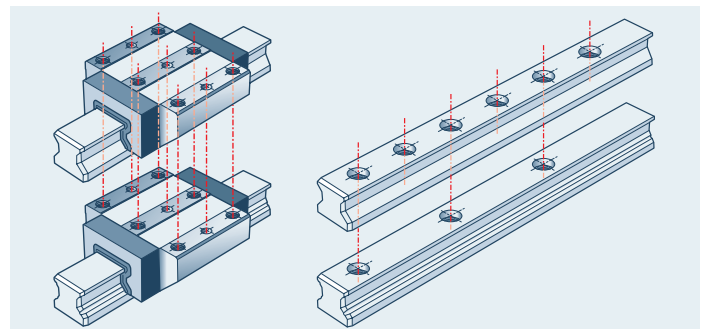

Your assurance for trouble-free modifications

If you need to upgrade existing machines or applications or wish to change systems, this is not a problem with components from Rexroth. Our standardized mounting hole patterns as per DIN 645-1 enable easy and efficient **interchangeability**. For example, you can switch from Ball to Roller Rail Systems at any time.

Runner Block types

Application possibilities

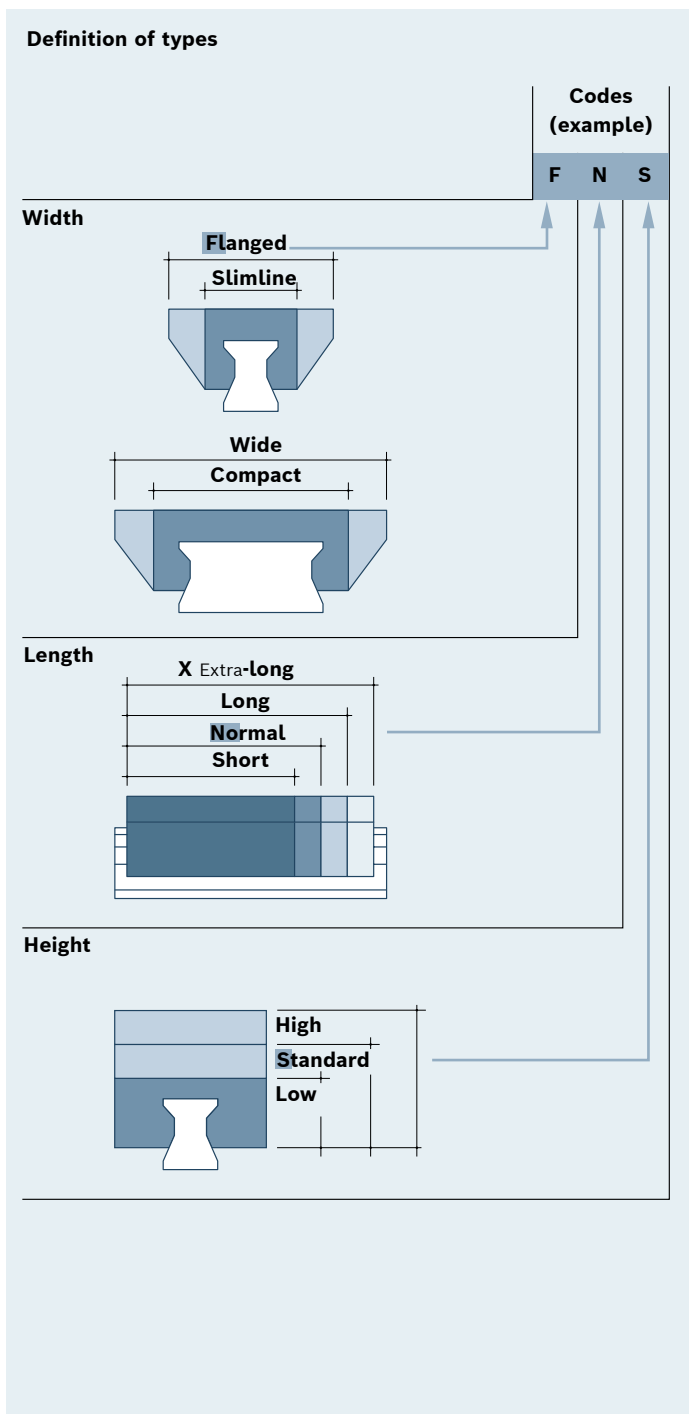

Application possibilities for all requirements under different environmental conditions

With our broad range of materials and types, we make sure that our solutions will match the requirements of the specific application.

One crucial criterion for suitability is the combination of materials used in the Runner Blocks and Guide Rails.

Steel: The most important and consequently most widespread version is used not only as a cost-efficient element in general machine construction but also as a high-precision component in machine tools and measuring instruments.

Aluminum: The economical alternative. The Runner Block body of wrought aluminum alloy saves up to 60% weight while providing the same load rating as the standard version.

Resist NR: The ideal version for applications requiring corrosion protection. The Runner Blocks have the same load ratings and moments as the standard versions.

Resist NR II: Since all parts are made of corrosion-resistant material as per EN 10088, these Runner Blocks offer maximum protection against corrosion with only minor reductions in load ratings and moments.

Resist CR: The corrosion-resistant Runner Block body with matte silver hard chrome plating offers the same load ratings and moments as the standard version. An alternative when the NR version is not available.

Resist CR II: black hard chrome-plated

NRFG: All steel components are made from corrosion-resistant steel in accordance with DIN EN 10088 and AISI/NSF51. Maximum protection against corrosion with only minimal reductions in load ratings and moments. Plastic parts made from certified material in accordance with guideline 2002/72/EC and FDA21CFR.

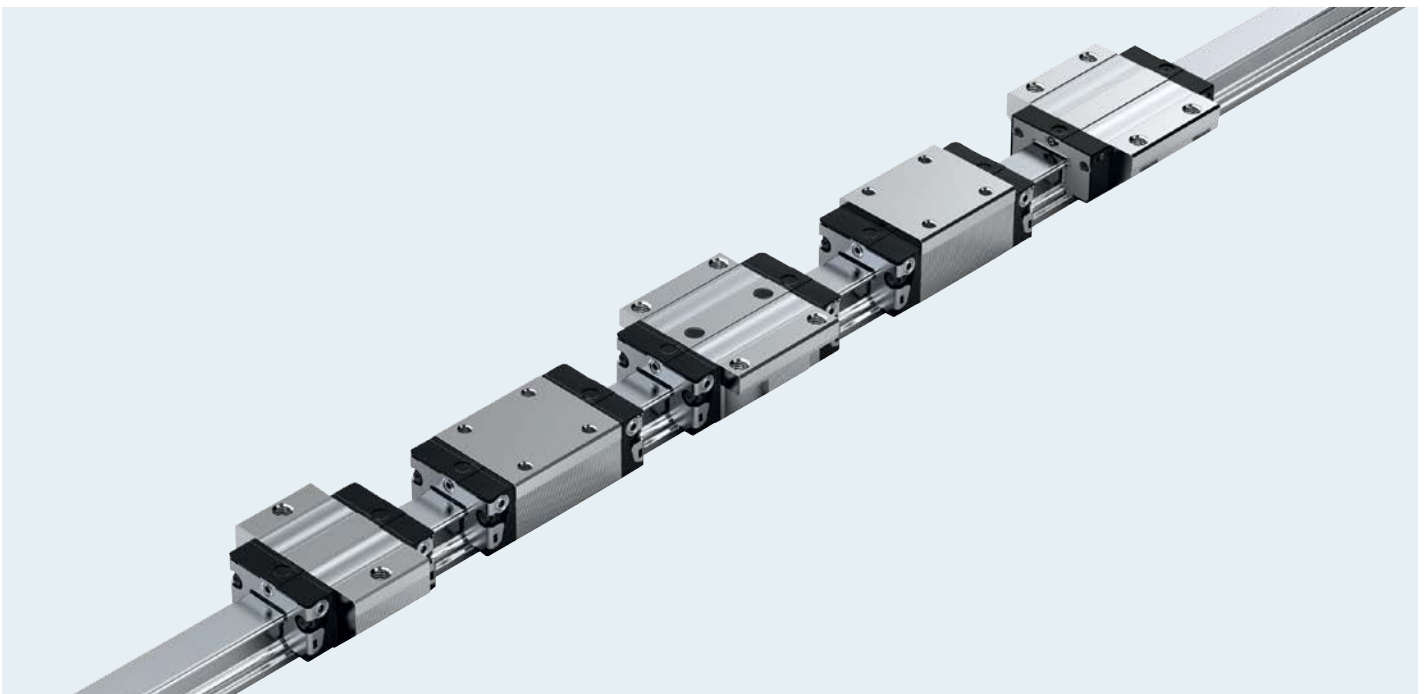

Unconditional flexibility

With products from Rexroth, you are opting for tried and trusted top technology that satisfies every wish in terms of quality, reliability and precision.

You gain that all-important competitive technical edge as well as a significant plus in efficiency on the installation and logistics level thanks to the immense flexibility we offer you with the **interchangeability** and **combinability** of our linear guides.

Another important advantage when working with Rexroth is our excellent service. From the first **information** supplied through to detailed **consulting** and individual **solution proposals**, the focus is always on you, the customer.

Perfect solutions for linear motion applications – plus extensive information to help you make your choice.

Our website **www.boschrexroth.com** has all product details and more:

- ▶ Selection Guide
- ▶ Online catalog
- ▶ Catalog downloads
- ▶ CAD data files as downloads
- ▶ eShop

You can also order printed information material easily via the webpage or submit a request for personalized consulting.

Make use of our extensive expertise.

Roller Rail Systems – maximum precision for demanding motion tasks



Rexroth Roller Rail Systems are designed to meet the highest demands on precision and rigidity in Linear Motion Technology. Our range offers compact, roller bearing-mounted linear guides in various accuracy classes. The Runner Blocks and Guide Rails feature extremely high load-bearing capacity and rigidity. The advantages of the roller bearing design greatly improve energy efficiency and achieve a mechanical efficiency that is 90% better than sliding guides. Rexroth's high-precision Roller Runner Blocks feature an optimized entry zone that helps the rollers take on loads smoothly and consistently, with maximum travel accuracy and minimum friction variation.

Characteristic features

- ▶ **Different types** with maximum precision in standard, wide, extra-long and heavy-duty versions
- ▶ **Limitless interchangeability** for total Roller Runner Block and Guide Rail combinability
- ▶ **Extremely high load ratings** in all four main directions of loading, **high torque load**
- ▶ **Maintenance-friendly lube nipples**, on all sides, if so desired
- ▶ **Integrated all-around sealing** as standard
- ▶ **Mounting of attachments** to Runner Block from above or below
- ▶ **Full interchangeability** thanks to standardized mounting hole patterns in accordance with ISO 12090
- ▶ **Minimal variation in elastic deflection** thanks to optimized entry-zone geometry

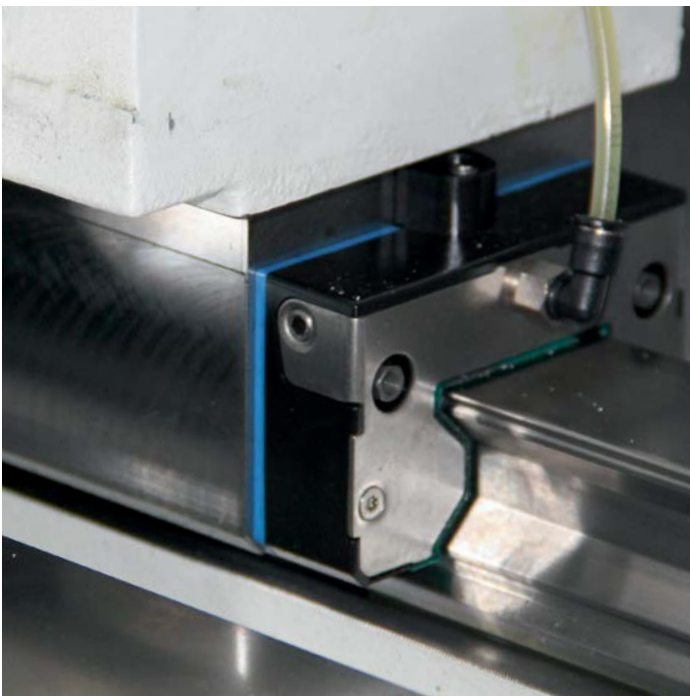

Roller Rail Systems in a machine tool

By using our high-performance Roller Rail Systems, you benefit in several different ways. The minimization of friction loss to just 10% compared to sliding guides has a direct impact on energy requirements and therefore on energy costs. Excellent precision and travel accuracy, regardless of the speed or load, help boost performance.

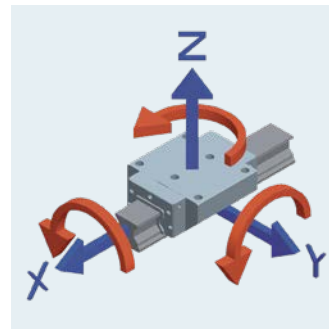

Highest rigidity

Our Roller Runner Blocks have top rigidity in all load directions for best precision and high travel accuracy.

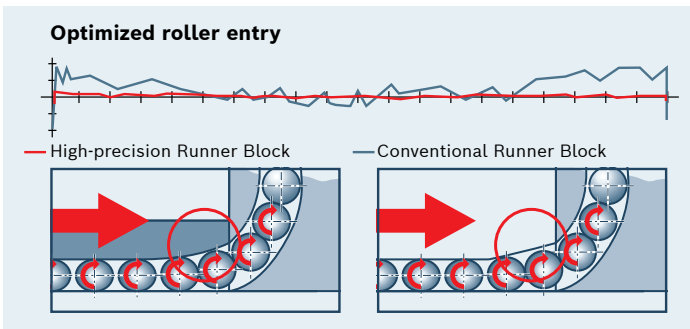

High-precision for better results and finish

The steel bearing plates are manufactured with such precision that they can withstand increasing load as curvature becomes more convex. The rollers no longer crash their way into the load-bearing zone through an oblique entry zone, rather transition smoothly on a tangential, ideally angled elastic line into the load-bearing zone.



Modular sealing concept standard

Double-lipped end-face seals prevent bearing contamination. Minimal lubrication required.

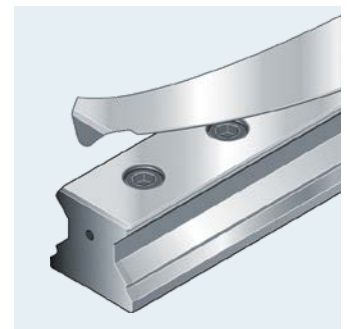

Proven cover strip

A single cover for all guide rail mounting holes, made of corrosion-resistant spring steel as per DIN EN 10088

- ▶ Simple and reliable
- ▶ Enormous time savings compared to individual covers

Runner Blocks

Standard Roller Runner Blocks

Steel or Resist CR

Corrosion-resistant Runner Blocks, Resist CR, matte silver hard chrome-plated, are available for exceptionally demanding conditions of use.

Optimized lube fittings allow for complete lubrication in any mounting position. Additional lubrication adapters are no longer necessary in high Roller Runner Blocks thanks to integrated height adjustment.



FNS
Oil/grease lubrication
 Sizes 25 – 65
One-point oil lubrication
 Sizes 35 – 55



FLS
Oil/grease lubrication
 Sizes 25 – 65
One-point oil lubrication
 Sizes 35 – 55



SLS
Oil/grease lubrication
 Sizes 25 – 65
One-point oil lubrication
 Sizes 35 – 55

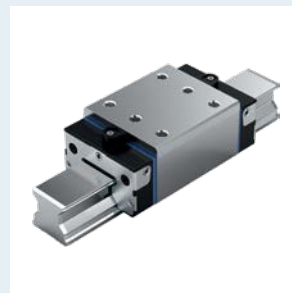

SNH
Oil/grease lubrication
 Sizes 25 – 55
One-point oil lubrication
 Sizes 35 – 55



SLH
Oil/grease lubrication
 Sizes 25 – 55
One-point oil lubrication
 Sizes 35 – 55



SNS
Oil/grease lubrication
 Sizes 25–55
One-point oil lubrication
 Sizes 35–55

Heavy-duty Roller Runner Block

Steel or Resist CR

Specially designed for heavy-duty applications requiring extremely high load-bearing capacity and rigidity.

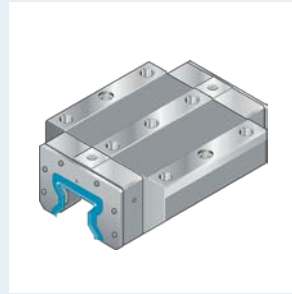

FNS
 Sizes 100, 125
 Exceptionally rigid, extremely high load-bearing capacity, for mounting from above and below

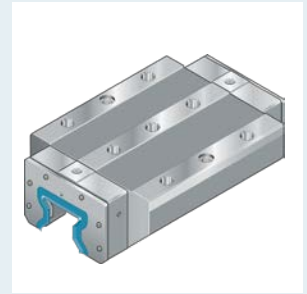

FLS
 Sizes 100, 125
 Exceptionally rigid, max. load on one runner block up to 200 t (size 125), for mounting from above and below



FXS
Extra-long version
Oil/grease lubrication
 Size 65
One-point oil lubrication
 Size 65

Wide Roller Runner Block

Steel or Resist CR

For single-rail applications to achieve high torque load.



BLS
 Sizes 55/85, 65/100
 High rigidity, high load capacity, for mounting from above and below

Roller Guide Rails and accessories

Roller Guide Rails

The Guide Rails have hardened and ground running tracks. Resist CR versions also available. Cover strip made of corrosion-resistant spring steel per EN 10088.



Standard Roller Guide Rail Steel or Resist CR

Sizes 25–125

For mounting from above

Size 100 available with steel caps or cover strip, size 125 (heavy-duty) with cover strip only



Standard Roller Guide Steel or Resist CR

Sizes 25–65

For mounting from below

Special Roller Guide Rail designs

Roller Guide Rail without base groove, wide Roller Guide Rail

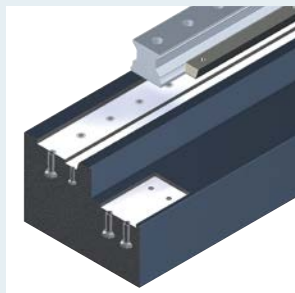

Roller Guide Rail without base groove

Sizes 35–65

Smooth base for mounting surfaces made from mineral-cast material. Full surface contact ensures precision guidance without rippling and variations in height



Wide Roller Guide Rail

Sizes 55/85, 65/100

For mounting from above, with cover strip, strip clamp with screws and washers

Cover options

Various options are available to cover mounting holes as required for the specific application.

Cover strip with plastic protective end caps



Cover strip with aluminum strip clamps



Cover Strip fasteners for heavy duty rails



Steel mounting hole plugs



Plastic mounting hole plugs



Accessories

Accessories

Additional application possibilities through add-ons



◀ **Scraper plate**

For scraping off coarse or stuck-on contamination, corrosion-resistant spring steel in accordance with DIN EN 10088

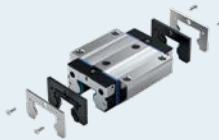

◀ **FKM seal**

Prevents dirt, liquid or small particles from entering the Runner Block. Easy mounting and removal even when Guide Rail is screwed down. Backing plate made of corrosion-resistant steel per EN 10088



◀ **FKM seal set with scraper plate**

Designed for mounting to Runner Block on Guide Rails with cover strip



◀ **Front Lube Unit**

For applications requiring travel up to 5,000 km without relubrication and for very long relubrication intervals



Bellow

High-quality polyester fabric with polyurethane coating to protect linear guides, also available in heat-resistant versions

Ball Rail Systems – precision for high-accuracy applications

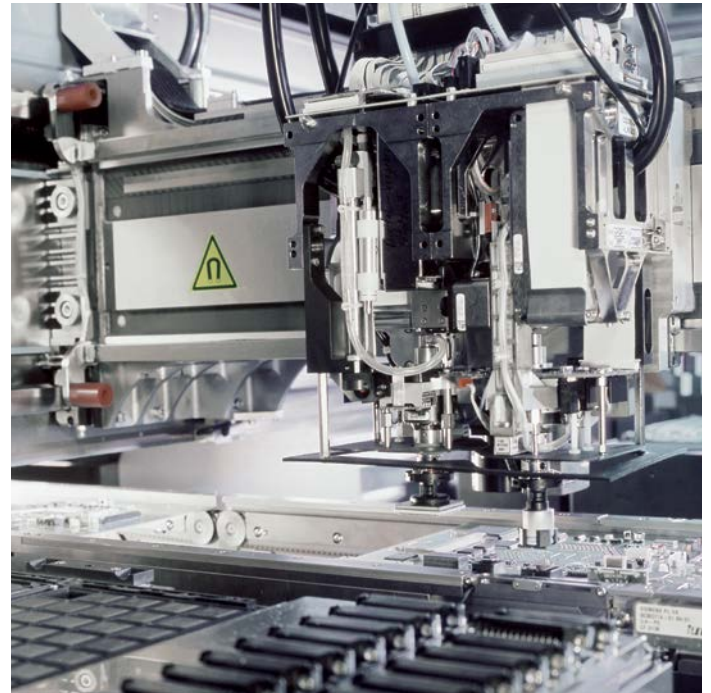
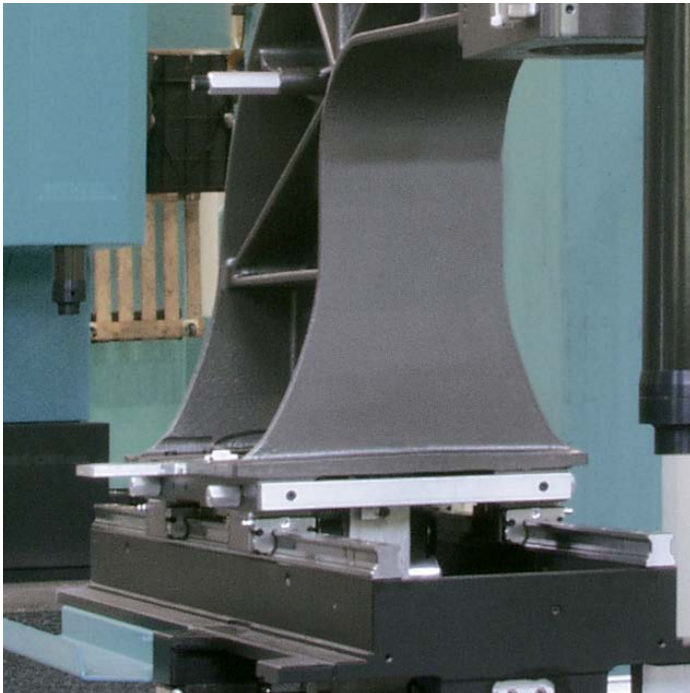

Our high-quality Ball Rail Systems are designed primarily for general mechanical engineering and tool manufacturing. These solutions feature performance and long service life. Special corrosion protection allows use even in harsh conditions. Our efficient minimum quantity lubrication system and wear-free roller bearings ensure high operating reliability and consistent precision throughout the system's service life.

Our high-precision Ball Rail Systems come with a special entry zone optimized to handle any load. This innovative solution ensures maximum travel accuracy while significantly reducing friction variation.

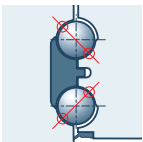

2-point contact

Minimal friction due to consistent use of 2-point contact throughout

Characteristic features

- ▶ **Limitless interchangeability;** all Ball Runner Block versions can be combined at will with all Ball Rail versions
- ▶ **Excellent dynamic characteristics:** speed up to 10 m/s, acceleration up to 500 m/s²
- ▶ **Integrated all-around sealing as standard,** additional seals for a variety of applications
- ▶ Same **load ratings** in all four main directions of loading
- ▶ Optimum **system rigidity** through O-arrangement of raceways
- ▶ **Different types** including special designs **such as high precision, high speed, and self-alignment feature,** as well as versions in aluminum or different corrosion-resistance grades, e.g. for food & packaging applications

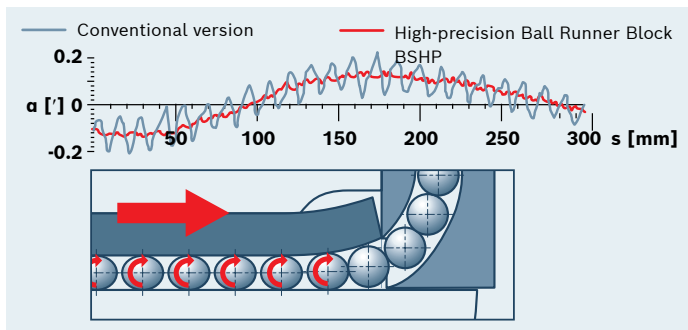

High precision with enhanced travel accuracy

The ball entry zone is key for travel. In the high-precision Ball Runner Blocks, an especially innovative design maximizes the travel accuracy. The entry zone adjusts individually to the actual operating load of the Ball Runner Block, as the steel bearing plates deflect as the balls pass them. The balls thus enter the load-bearing zone very smoothly, i.e., without any load pulsation.

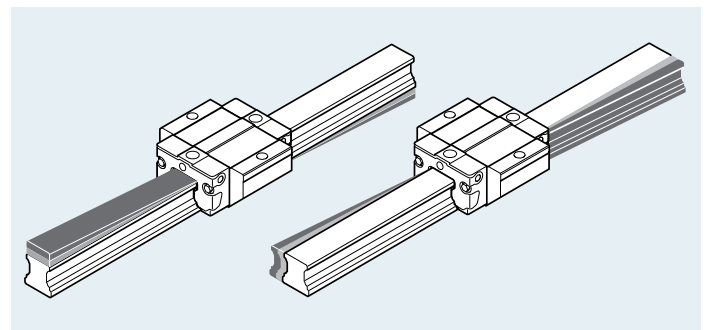

Super Ball Runner Blocks with self-alignment feature

Rexroth Super Ball Runner Blocks with self-alignment compensate for alignment errors of up to 10', assuring that the balls enter the load-bearing zone smoothly and that the load is evenly distributed. The centers of the mating surfaces supporting the steel bearing plates serve as a rocking fulcrum. Misalignments of the Runner Block and the Guide Rail are therefore not a problem. The result is extra-smooth running and considerably longer service life.

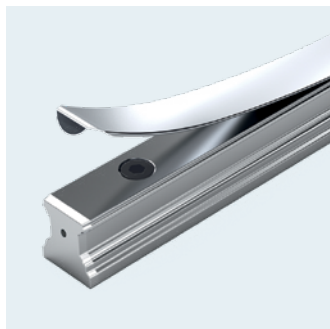

Proven cover strip

A single cover for all Guide Rail mounting holes, made of corrosion-resistant spring steel as per DIN EN 10088

- ▶ Simple and reliable
- ▶ Enormous time savings compared to individual covers

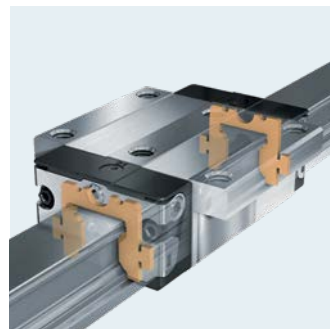

Low-friction seal

For special demands on smooth travel in environments with low contamination. Minimal friction resistance for high energy efficiency.

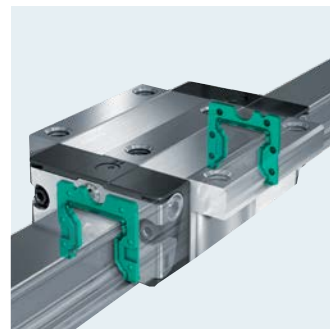

High-efficiency seal

This version effectively prevents chips, wood dust, metalworking fluids, and other contaminants from working their way into the runner block.



Special requirements

Version for the food industry. NRFG-based on corrosion-resistant Runner Block (Resist NR II) with special features: Food Graded (FG).

Runner Blocks

High-precision Ball Runner Blocks

Steel; Resist NR or Resist CR available

High rigidity in all load directions – suitable for single-Runner Block applications. Increased travel accuracy with high-precision versions (up to a factor of six).



FNS
Steel, sizes 15–65
Resist NR, sizes 15–35
Resist CR, sizes 45–65
High-precision, sizes 15–45
 For high rigidity requirements, high load-bearing capacity



SNS
Steel, sizes 15–65
Resist NR, sizes 15–35
Resist CR, sizes 45–65
High precision, sizes 15–45
 For restricted space in transverse direction, high load-bearing capacity



SNH
Steel, sizes 15–55
Resist CR, sizes 25–55
High-precision, sizes 15–45
 For restricted space in transverse direction, high load-bearing capacity, higher rigidity than SNS



Our Ball Runner Blocks can be equipped with a Ball Chain to optimize noise levels.



FLS
Steel, sizes 15–65
Resist NR, sizes 15–35
Resist CR, sizes 45–65
High-precision, sizes 15–45
 For very high rigidity requirements, very high load-bearing capacity



SLS
Steel, sizes 15–65
Resist NR, sizes 15–35
Resist CR, sizes 45–65
High-precision, sizes 15–45
 For restricted space in transverse direction, very high load-bearing capacity



SLH
Steel, sizes 15–55
Resist CR, sizes 25–55
High-precision, sizes 25–45
 For restricted space in transverse direction, high rigidity, very high load-bearing capacity, higher rigidity than SLS

High-precision Ball Runner Blocks

Steel; Resist NR or Resist CR available

Optimal rigidity for standard applications. Short and low-profile versions.



FKS

Steel, Resist NR
Sizes 15–35

Restricted space in longitudinal direction, medium load-bearing capacity, for mounting from above and below, supplementary to DIN 645-1



SKS

Steel, Resist NR
Sizes 15–35

For restricted space in longitudinal and transverse direction, medium load-bearing capacity, for mounting from above



FNN

Steel, Resist CR
Sizes 20, 25

For restricted space in vertical direction, high load-bearing capacity, lower rigidity than FNS, not defined in DIN 645-1



SNN

Steel, Resist CR
Sizes 20, 25

For restricted space in vertical and transverse direction, high load-bearing capacity, lower rigidity than SNS, not defined in DIN 645-1



FKN

Steel, Resist CR
Sizes 20, 25

For restricted space in vertical and longitudinal direction, medium load-bearing capacity, lower rigidity than FKS, not defined in DIN 645-1



SKN

Steel, Resist CR
Sizes 20, 25

For restricted space in vertical, longitudinal and transverse direction, medium load-bearing capacity, lower rigidity than SKS, not defined in DIN 645-1

Super Ball Runner Blocks

Steel; Resist CR available



FKS
Super Ball Runner Block
Steel or Resist CR
 Sizes 15–35
 For compensating large tolerances in the adjoining structure

Automatic compensation of alignment errors, resulting in much smoother running and considerably longer service life.
 At least two Ball Runner Blocks per rail required, medium load-bearing capacity.



SKS
Super Ball Runner Block
Steel or Resist CR
 Sizes 15–35
 For compensating large tolerances in the adjoining structure

Standard Ball Runner Blocks

Aluminum

Up to 60% weight saving with high load-bearing capacity. The steel insert technology assures the same load capacities as the steel version up to the maximum load-bearing capability of the aluminum body.

High-speed Ball Runner Blocks

High-speed steel

Sizes 15–35
 For exceptionally high speeds up to 10 m/s, high load capacity, for mounting from above and below



FNS



SNS



FLS



SLS

Excellent dynamic characteristics and very high speeds thanks to high-quality ceramic balls, high load-bearing capacity.

Wide Ball Runner Blocks

Steel; Resist CR available

Can be used as a single runner block in one-rail applications due to very high torque load capacity and torsional stiffness.



FNS
Aluminum
 Sizes 15–35

For lightweight designs, for offsetting low tolerances in the adjoining structure, for mounting from above or below



SNS
Aluminum
 Sizes 15–35

For lightweight designs, for compensating slight tolerances in the adjoining structure, for mounting from above

Ball Runner Blocks

Resist NR II
 Sizes 15–35

For restricted space in the transverse direction, high load-bearing capacity, for mounting from above



FNS

Ball Runner Block made **entirely** of corrosion-resistant steel in accordance with DIN EN 10088 for harsh environments. All types come in sizes 15–35. Runner Block NRFG is also available for use in the food industry.



SNS



BNS
Steel, Resist CR
 Sizes 20/40, 25/70, 35/90

For high torsional moments in one-rail applications, very high load-bearing capacity, for mounting from above and below



CNS
Steel, Resist CR
 Sizes 20/40, 25/70

For high torsional moments in one-rail applications with restricted space in transverse direction, very high load-bearing capacity, for mounting from above



FKS



SKS



FLS



SLS

Guide Rails and accessories

Ball Guide Rails

The Guide Rails have hardened and ground running tracks. Resist CR or Resist CR II versions also available. Cover strip made of corrosion-resistant spring steel per EN 10088.

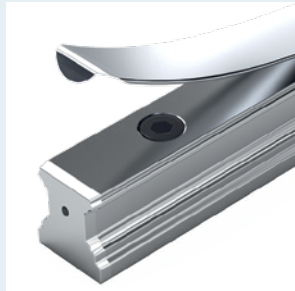

Standard Ball Guide Rail for mounting from above Steel, Resist CR or Resist CR II

Sizes 15–65

Resist NR II
Sizes 15–35

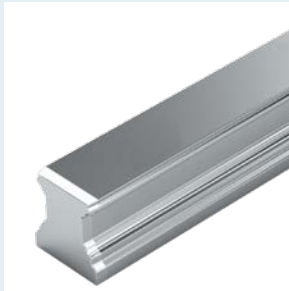

Standard Ball Guide Rail for mounting from below Steel, Resist CR, or Resist CR II

Sizes 15–65

Resist NR II
Sizes 15–35

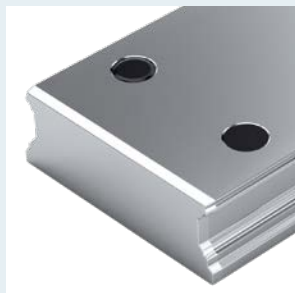

Wide Ball Guide Rail for mounting from above Steel, Resist CR or Resist CR II

Sizes 20/40–35/90

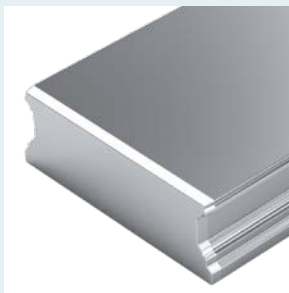

Wide Ball Guide Rail for mounting from below Steel, Resist CR or Resist CR II

Sizes 20/40–35/90

Cover options

Various cover options to meet all environmental requirements.

Cover strip with aluminum strip clamps



Cover strip with plastic protective end caps



Plastic mounting hole plugs



Steel mounting hole plugs



Accessories

for additional application possibilities

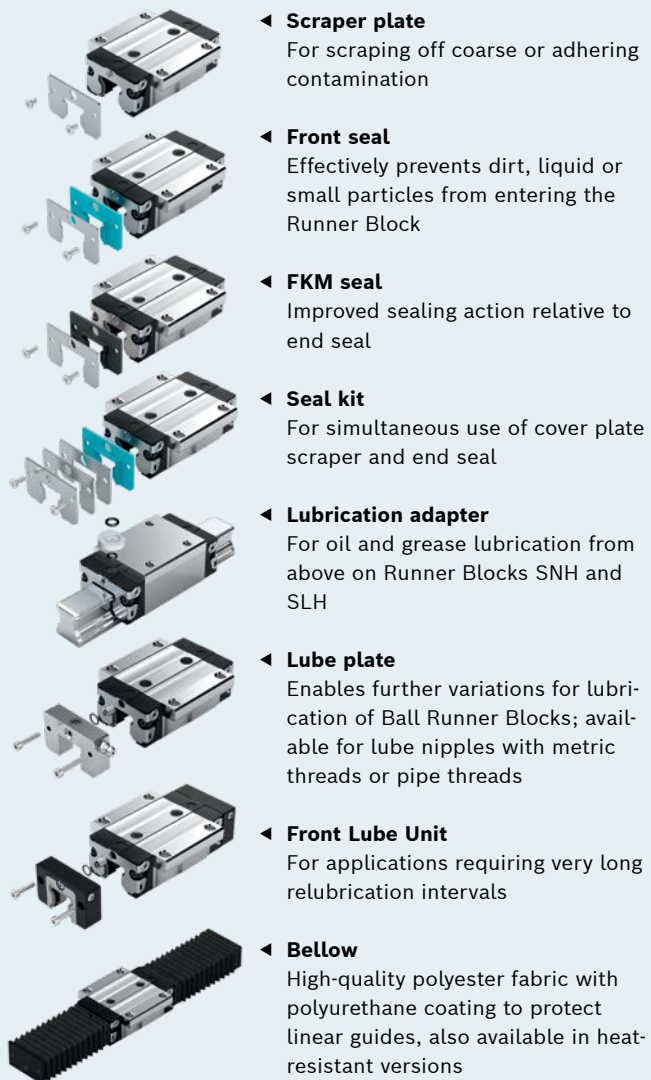

◀ **Scraper plate**

For scraping off coarse or adhering contamination

◀ **Front seal**

Effectively prevents dirt, liquid or small particles from entering the Runner Block

◀ **FKM seal**

Improved sealing action relative to end seal

◀ **Seal kit**

For simultaneous use of cover plate scraper and end seal

◀ **Lubrication adapter**

For oil and grease lubrication from above on Runner Blocks SNH and SLH

◀ **Lube plate**

Enables further variations for lubrication of Ball Runner Blocks; available for lube nipples with metric threads or pipe threads

◀ **Front Lube Unit**

For applications requiring very long relubrication intervals

◀ **Bellow**

High-quality polyester fabric with polyurethane coating to protect linear guides, also available in heat-resistant versions

Integrated Measuring System IMS for Ball and Roller Rail Systems

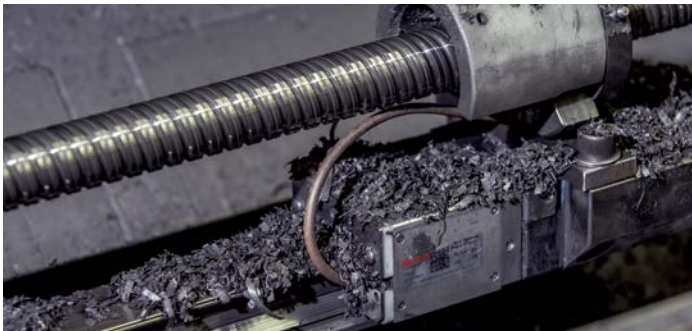
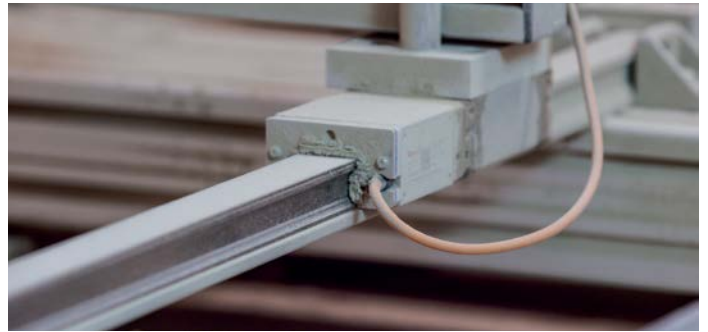
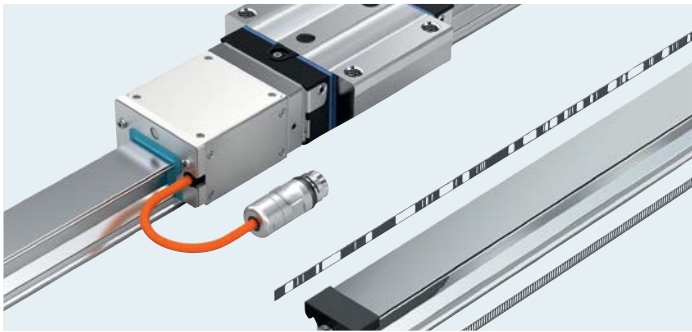

Inductive – precise – integrated

Rexroth Ball and Roller Rail Systems are available with the integrated, inductive position measuring system IMS. This system delivers comparable system accuracy to high-precision glass scales. IMS is recommended for machine tools as an excellent alternative to external measuring solutions. The system consists of sensors built into a scanner, which is attached to the Runner Block. When traversing the scale, it scans the reference marks or absolute code strip on the Guide Rail. Contactless position measuring directly on the workpiece/tool at a resolution of $0.025 \mu\text{m}$.

Your benefit: Excellent workpiece quality thanks to precise position resolution and extreme repeatability.

Characteristic features

- ▶ **Guidance and measurement combined into one compact unit** No additional space needed for external measuring systems
- ▶ **Position resolution up to $0.025 \mu\text{m}$**
- ▶ **Pitch accuracy: $\pm 3 \mu\text{m}$**
- ▶ **System accuracy: $\pm 4 \mu\text{m/m}$**
- ▶ **High system accuracy**, no additional assembly or calibration required
- ▶ **Maintenance- and wear-free** thanks to contactless scanning
- ▶ **Robust against contamination:** resistant to water, dust, shavings, oil, etc.
- ▶ **Unsusceptible to magnetic fields**

Precise guidance and measurement – for maximum production quality

IMS position measuring systems by Bosch Rexroth come in incremental (IMS-I) and absolute (IMS-A) versions.

Superior to external solutions: optimized workpiece quality thanks to high-precision position resolution and outstanding repeatability.



IMS-A: Integrated Measuring System Absolute

With absolute and incremental scales

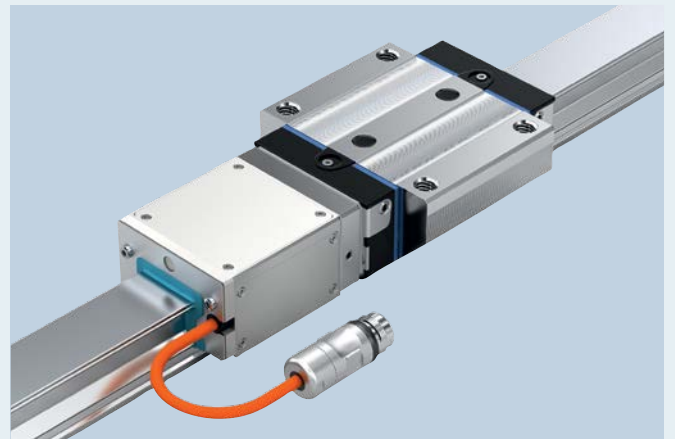

IMS-I: Integrated Measuring System Incremental

With incremental scale and integrated reference marks

Your benefits:

- ▶ Measurement is integrated directly into the linear guide.
- ▶ Inductive, contactless and wear-free measuring principle
- ▶ Ready to use: The absolute position information of the IMS-A is available as soon as the system is activated. No homing cycle necessary.
- ▶ Robust against contamination
- ▶ Maintenance-free
- ▶ Saves space and money
- ▶ Exact positioning even with dynamic load changes
- ▶ Outstanding circuit dynamics due to high position resolution
- ▶ Absolute positioning without backup battery

Miniature Ball Rail System – small but strong

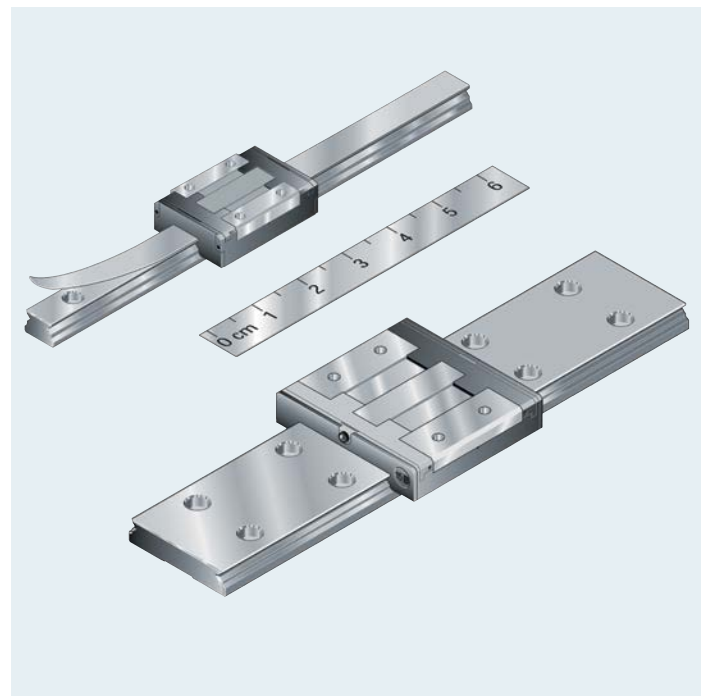

The miniature version of the Ball Rail System was specially designed for compact applications in the medical and automation sectors, as well as in the electrical industry. These areas in particular require extremely small longitudinal systems with high load capacities. Our products offer exceptional performance in these sizes. This system optimally meets the very special requirements of these production systems thanks to the high load ratings of the rail units in all four main load directions.

Cleanroom applications can also be served, and appropriate certifications have been obtained. Since use in these areas depends on many different factors, please contact our specialists for more information.

Characteristic features

- ▶ **Uniform Guide Rails** with or without cover strip allows limitless interchangeability
- ▶ All steel parts of the Runner Block and the Guide Rail are made of **rust and acid resistant material** similar to ISO 683-17 / EN 10088
- ▶ Guide Rails **also available with cover strip**
- ▶ **High load-bearing** capacities in all load directions, including moments about all axes, due to the use of largest possible ball sizes
- ▶ Smooth running thanks to **optimized ball recirculation and guidance**
- ▶ **Easy mounting and replacement** without loss of balls due to special ball retention feature
- ▶ Size 15 and up with **lube nipples on end faces** and **relubrication ports on the sides**

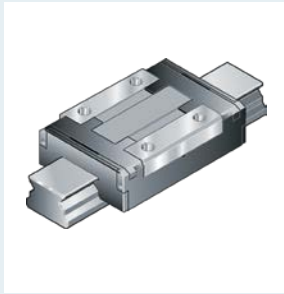

**Miniature Runner Block
R0442...,
standard**

Sizes 7, 9, 12, 15, 20

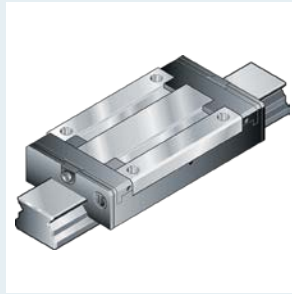

**Miniature Runner Block
R0444...,
long**

Sizes 7, 9, 12, 15

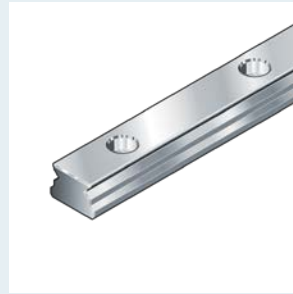

**Miniature Guide Rail
R0445...,
standard**

Sizes 7, 9, 12, 15, 20

For mounting from above

Sizes 9, 12, 15

One-piece Guide Rails up to
2,000 mm available

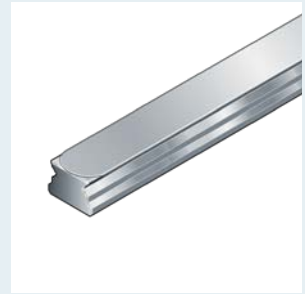

**Miniature Guide Rail
R0445...,
standard**

Sizes 9, 12, 15, 20

For mounting from above,

with cover strip made of
corrosion-resistant spring
steel in accordance with DIN
EN 10088

Size 15 also available for
mounting from below



**Miniature Runner Block
R0443...,
wide**

Sizes 9B, 12, 15

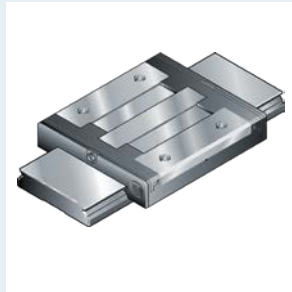

**Miniature Runner Block
R0441...,
wide, long**

Sizes 9B, 12, 15

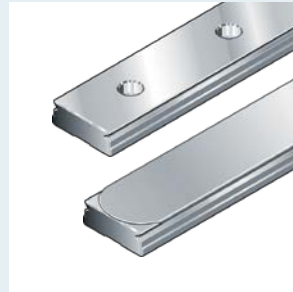

**Miniature Guide Rail
R0455...,
standard**

Sizes 9, 12

For mounting from above,
with or without cover strip
made of corrosion-resistant
spring steel per EN 10088

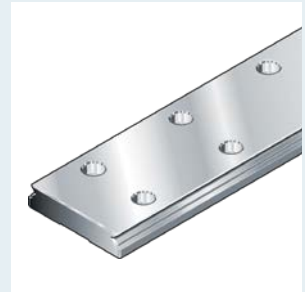

**Miniature Guide Rail
R0455...,
wide**

Size 15

For mounting from above,
two rows of mounting holes
One-piece Guide Rails up to
2,000 mm available

Cam Roller Guides – impressive performance: lightweight, silent and fast

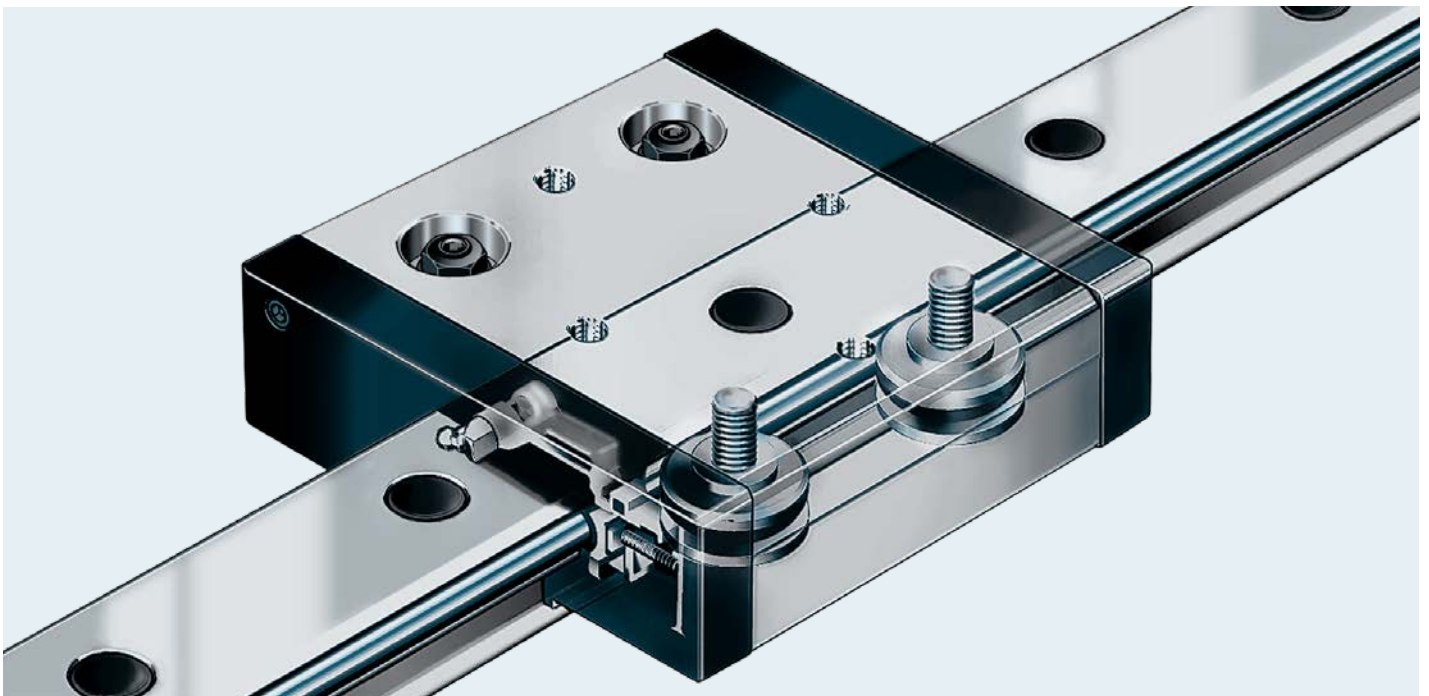

Cam Roller Guides from Rexroth were developed primarily for handling and automation applications. With their special features – compact design, very low weight, low friction and extremely low-noise operation – they perform excellently in such tasks. Their biggest advantage is their unbeatable dynamics, as their low-friction movement allows extremely high speeds.

Characteristic features

- ▶ **Extremely high dynamics**, with speeds up to 10 m/s and outstanding, low-noise operation
- ▶ **Two-row angular-contact ball bearings for especially smooth motion**, sealed and lubed for life (large oil reservoir), oil applicator/scrapper units at both ends
- ▶ **Various types:** Standard, Super, Profile, U-type and Single/Double Bearing Runner Blocks
- ▶ **Easy, zero-clearance adjustment** of Runner Blocks through eccentric spigots
- ▶ **Can be ordered separately**, thus simplifying logistics
- ▶ Guide Rails made of **anodized aluminum with integrated running tracks** made from corrosion-resistant precision steel shafts



Standard Runner Block R1902..

Sizes 20, 25, 32, 52, 52-h, 52-sh

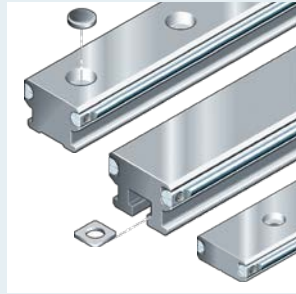

Standard Guide Rail R1921..

Sizes 20, 25, 32, 32-2, 52, 52-2, 52-4

Guide Rail with slot R1922..

Sizes 25, 32, 52

Guide Rail R1924.., low-profile

Sizes 32, 32-2, 52, 52-2, 52-4

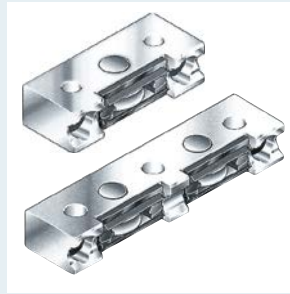

Single-bearing Runner Block R1903.., with adjusting screws

Sizes 32, 52, 52-h, 52-sh

Double-bearing Runner Block R1904.., with adjusting screws

Sizes 32, 52, 52-h, 52-sh

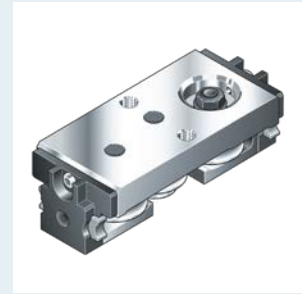

U-type Runner Block R1905..

Size 20



Super Runner Block R1906..

Sizes 20, 25

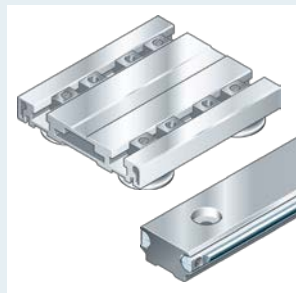

Profile Runner Block R1907..

Guide Rail R1921.., standard

Size 42

Anodized aluminum with integrated running tracks

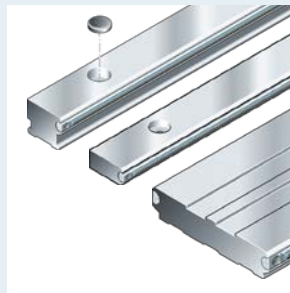

Guide Rail for Single/Double Bearing Runner Blocks, Standard, Half-Rail R1925..

Guide Rail for Single/Double Bearing Runner Blocks, Low-Profile, Half-Rail R1926..

Sizes 32, 32-2, 52, 52-2, 52-4

Guide Rail for Single/Double Bearing Runner Blocks, Wide R1927..

Sizes 52-120

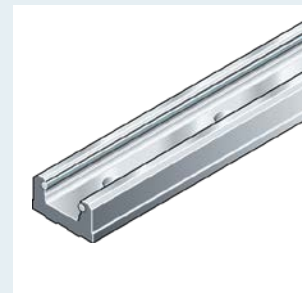

U-type Guide Rail R1923..

Size 20

For mounting from above, anodized aluminum with integrated running tracks

Linear Bushings and Shafts – proven technologies for handling and automation

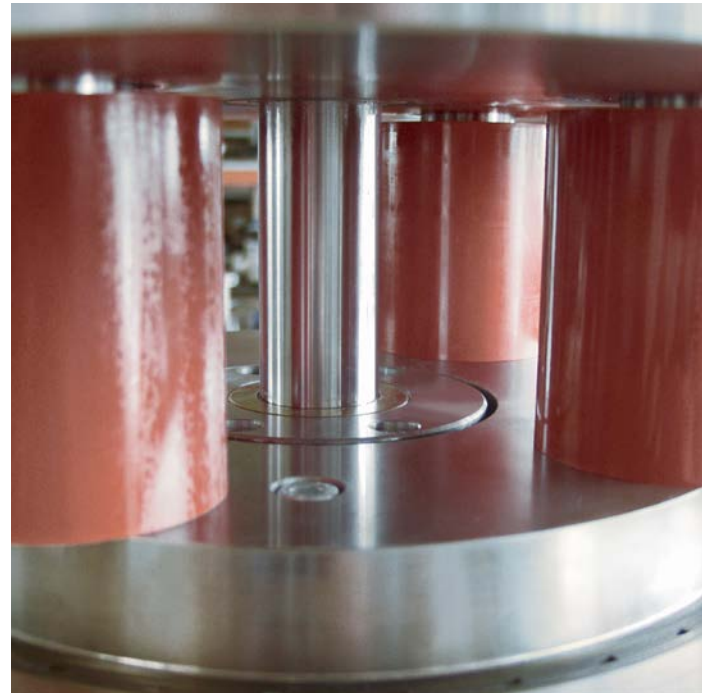

Linear Bushings and Shafts from Rexroth have proved their worth over many decades. Their uses are practically unlimited. The great diversity of types, versions and materials used for the elements opens up applications beyond the classic areas of general and special-purpose machinery, jigs and fixtures, enabling powerful solutions for tasks in, for example, the food, semiconductor and medical technology industries. Linear Bushings and Shafts show impressive performance in environmental conditions involving heavy contamination or high thermal loads. They are also renowned for their long service life, accuracy and high degree of efficiency.

Characteristic features

- ▶ **Many different versions:** closed or open, standard or corrosion-resistant, with or without holding rings, sealing rings and side seals, with or without flanges, as Linear Sets
- ▶ **Temperature-resistant up to 200 °C**
- ▶ **Long service life, high running speed and extra rigidity**
- ▶ Excellent running characteristics: **low friction, smooth travel**
- ▶ Compensate for **misalignments or shaft deflection**
- ▶ **Radial clearance adjustable** in slotted or open Linear Bushings and in adjustable Linear Sets
- ▶ **Easy, cost effective mounting**

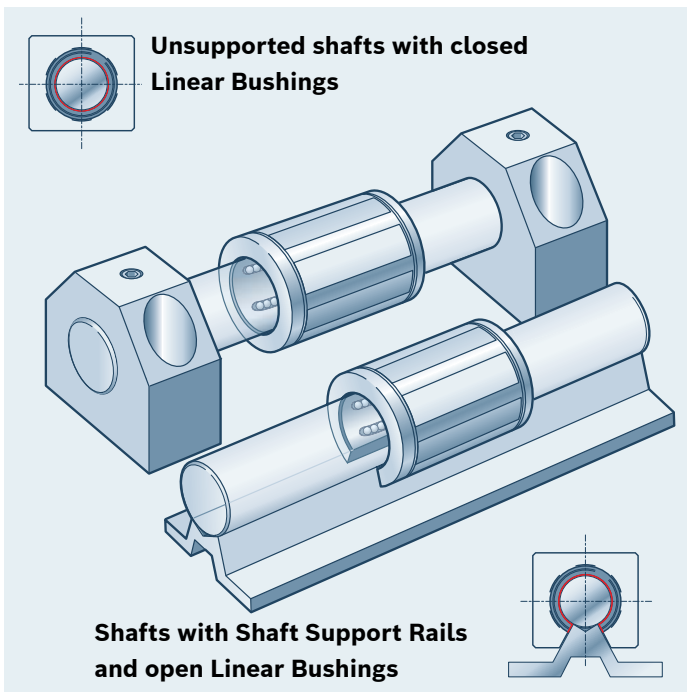

Application-oriented, individual solutions

Meeting special requirements and creating individual solutions that fulfill specifications in all respects are the benefits you can expect when working with Rexroth. Linear Bushings can withstand higher installation tolerances. For short-stroke applications, self-supporting guides with closed Linear Bushings are the best choice. For longer travel distances, linear guides with Shaft Support Rails and open Linear Bushings are used.

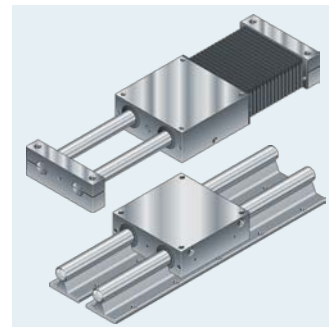

Linear motion system without drive

We focus on delivering rapid and economical solutions. With complete units we reduce your effort for in-house fabrication, mounting and adjustment.

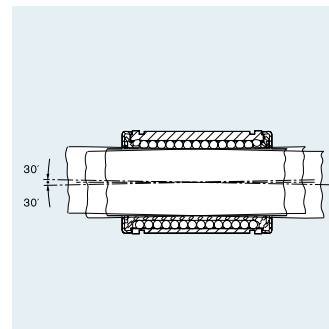
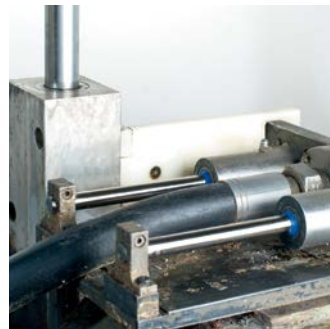
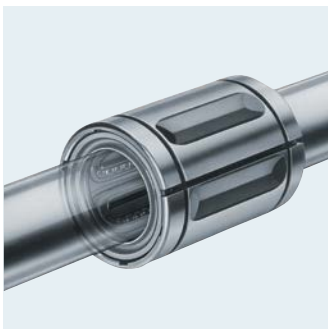

All-metal version for demanding requirements

Our standard Linear Bushings have internal ball bearing guides made of steel instead of a plastic ball retainer and can therefore resist temperatures up to 200°C without any seals. The all-metal version is also outstandingly well-suited for environments with heavy contamination.

Compensation for misalignments

Super Linear Bushings are able to compensate for misalignments or shaft deflections up to 0.5 degrees and therefore save effort when fabricating adjoining structures.

Cost-saving Linear Sets

Utmost precision thanks to highly accurate machining. Ready-to-mount units for cost-effective implementation.

Unsupported Linear Bushings and Shafts – with closed-type Linear Bushings

Super Linear Bushings and Linear Sets

Unbeatably smooth ball circulation, self-alignment feature, hardened and ground steel bearing plates with ball guide grooves.

A, **H**, **SH** = Super Linear Bushing **with** self-alignment up to $30' = 0.5^\circ$ (Series H and SH are especially suited for applications with higher loads and durability requirements as a result of the increased number of steel bearing plates.)

B = Super Linear Bushing **without** self-alignment



Super Linear Bushing **A R0670...**
closed, self-aligning

Shaft diameter 10–50 mm
Hardened steel bearing plates with ground ball tracks, with or without two integrated wiper seals



Linear Set R1035...
closed

Shaft diameter 10–50 mm
Aluminum precision housing (lightweight design), with Super Linear Bushing **A** or **B**, relubricatable, with two wiper seals



Linear Set R1085...
tandem, closed

Shaft diameter 12–50 mm
Aluminum precision tandem housing (lightweight design), two Super Linear Bushings **A**, two external seals



Super Linear Bushing **B R0672...**
closed, non-self-aligning

Shaft diameter 10–50 mm
With or without two integrated wiper seals



Linear Set R1036...
closed, adjustable

Shaft diameter 10–50 mm
Aluminum precision housing (lightweight design), with Super Linear Bushing **A** or **B**, relubricatable, with two wiper seals



Linear Set R1032...
tandem, closed, adjustable

Shaft diameter 10–50 mm
Aluminum precision tandem housing (lightweight design), two Super Linear Bushings **A**, two external seals



Linear Set R1083.., flanged



Shaft diameter
12–30 mm

Aluminum precision flanged housing (lightweight design), two Super Linear Bushings , integrated wiper seals



Linear Set R1081.., flanged

Shaft diameter
12–50 mm

Lamellar graphite cast iron precision flanged housing, two Super Linear Bushings  or , integrated wiper seals



Super Linear Bushing  R0732.., closed, self-aligning



Shaft diameter
20–60 mm

Additional rows of balls for higher load capacities, ground ball tracks, with or without two integrated wiper seals



Linear Set R1701.., closed



Shaft diameter
20–60 mm

Aluminum precision housing (lightweight design), with Super Linear Bushing  or , relubricatable, with two wiper seals



Linear Set R1065.., closed
Linear Set R1066.., closed, adjustable

Shaft diameter
12–50 mm

Lamellar graphite cast iron/steel precision housing, Super Linear Bushing  or , integrated wiper seals



Super Linear Bushing  R0730.., closed, self-aligning



Shaft diameter
20–50 mm

Additional steel bearing plates with ground ball tracks, with or without integrated wiper seals



Linear Set R1072.., closed, adjustable

Shaft diameter
20–60 mm

Aluminum precision housing (lightweight design), Super Linear Bushing  or , relubricatable, with two wiper seals

Unsupported Linear Bushings and Shafts – with closed-type Linear Bushings

Standard Linear Bushings and Linear Sets

Robust, hard-wearing design, particularly suitable for tough demands.
 Can be used without seals up to 200 °C. Hardened and ground outer sleeves.
 Corrosion-resistant steel or ball bearing steel in accordance with DIN EN 10088.



Standard Linear Bushing, closed, R0600.., without wiper seals R0602.., with two wiper seals
 Shaft diameter 3–80 mm
 Steel ball retainer, wiper seals or integrated steel holding rings, closed, for use on unsupported shafts



Standard Linear Bushing, closed, corrosion-resistant, R0600.., without wiper seals R0602.., with two wiper seals
 Shaft diameter 3–40 mm
 Steel ball retainer, with two wiper seals or integrated steel holding rings



Standard Linear Bushing, flanged, R0740.., normal R0740.., corrosion-resistant
 Shaft diameter 5–40 mm
 Steel or plastic ball retainer, with wiper seals



Standard Linear Bushing, adjustable, R0610.., without wiper seals R0612.., with two wiper seals
 Shaft diameter 5–80 mm
 Steel ball retainer, with two wiper seals or integrated steel holding rings, adjustable radial clearance



Standard Linear Bushing, tandem, R0650.., normal with wiper seals R0650.., corrosion-resistant with wiper seals
 Shaft diameter 8–40 mm
 Steel or plastic ball retainer, with wiper seals



Standard Linear Bushing, flange tandem, R0741.., normal R0741.., corrosion-resistant
 Shaft diameter 8–40 mm
 Steel or plastic ball retainer, with wiper seals



Standard Linear Bushing, center flange tandem R0742.., normal R0742.., corrosion-resistant

Shaft diameter 8–40 mm

Steel or plastic ball retainer, with wiper seals



Linear Set R1065.., closed R1066.., adjustable

Shaft diameter 8–80 mm

Lamellar graphite cast iron/ steel precision housing, standard Linear Bushing with two wiper seals, two retaining rings



Linear Set R1081.., flanged,

Shaft diameter 12–80 mm

Lamellar graphite cast iron flanged housing, standard Linear Bushing with two wiper seals



Unsupported Linear Bushings and Shafts – with closed-type Linear Bushings

Compact Linear Bushings and Linear Sets

Highly compact Linear Guides
with small outer dimensions.
With integrated wiper seals.



**Compact Linear Bushing
R0658...**

Shaft diameter
12–50 mm



**Compact Linear Bushing
R0658...**

Shaft diameter
8, 10 mm



**Compact Linear Set
R1027...,
closed**

Shaft diameter
12–50 mm

Aluminum precision housing
(lightweight design), with
Compact Linear Bushing
R0658..., size 12–50 mm



**Compact Linear Set
R1028...,
adjustable**

Shaft diameter
12–50 mm

Aluminum precision housing
(lightweight design), with
Compact Linear Bushing
R0658..., size 12–50 mm



**Compact Linear Set
R1027..., tandem, closed**

Shaft diameter
12–50 mm

Aluminum precision housing
(lightweight design), with
Compact Linear Bushing
R0658..., size 12–50 mm

Accessories

Segmental Linear Bushings and Linear Sets



Proven in the food, film and photography industries as a low-priced linear guide. Multi-purpose. Corrosion-resistant steel or ball bearing steel per EN 10088.

Segmental Linear Bushing R0668.., normal R0668.., corrosion-resistant

Shaft diameter 12–40 mm
 Balls made of ball bearing steel, hardened segmental steel load-bearing plates, polyamide ball retainer



Linear Set, adjustable R1060.., normal R1060.., corrosion-resistant

Shaft diameter 12–40 mm
Reinforced polyamide pillow block housing, with Segmental Linear Bushing, two replaceable wiper seals, adjustable radial clearance

Lube nipples

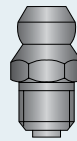

Retaining rings



Wiper seals



Locating screws



Adjusting screws



Unsupported Linear Bushings and Shafts – with closed-type Linear Bushings

Torque-Resistant Linear Bushings and Linear Sets

Compact design for full linear guidance with only one shaft. Especially suited for jigs, fixtures and special machines. Linear Sets are delivered complete with the matching precision steel shaft with ball guide grooves, always ready-mounted and adjusted to zero clearance. Type 1 with one ball guide groove, Type 2 with two ball guide grooves. Matching Linear Bushings also available without shaft. Corrosion-resistant steel or ball bearing steel per EN 10088. Torque-Resistant Linear Sets with external seals.



Torque-Resistant Linear Bushing R0696..., Type 1

Shaft diameter
12–50 mm

Torque-Resistant Linear Bushing R0696..., Type 2

Shaft diameter
20–50 mm
Separate wiper seals



Linear Set R1098..., tandem Linear Set R1099..., Type 1 aluminum

Shaft diameter
12–50 mm

Linear Set R1098x, tandem Linear Set R1099..., Type 2, aluminum

Shaft diameter
20–50 mm

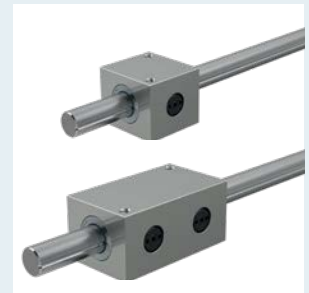

Linear Set R1096..., tandem Linear Set R1097..., Type 1, steel

Shaft diameter
12–50 mm

Linear Set R1096..., tandem Linear Set R1097..., Type 2, steel

Shaft diameter
20–50 mm



Torque-Resistant Compact Linear Bushing R0720...

Shaft diameter
12–50 mm

Plastic ball retainer and outer sleeve, hardened steel bearing plates, separate wiper seals



Compact Linear Set R0721...

Shaft diameter
12–50 mm

Steel compact outer sleeve or flanged sleeve, Torque-Resistant Compact Linear Bushing



Compact Linear Set R0722..., tandem

Shaft diameter
12–50 mm

Steel compact outer sleeve, two Torque-Resistant Compact Linear Bushings

Torque-Resistant Linear Bushings with four ball guide grooves

Compact design for full linear guidance with only one shaft.
Enhanced torque resistance thanks to four ball guide grooves.
Integrated wiper seals.



Torque-Resistant Linear Bushing R0724 2
Four ball guide grooves

Shaft diameter
4–50 mm
Hardened and ground outer sleeve, plastic ball retainer, feather key for torque transmission



Torque-Resistant Linear Bushing R0726.., miniature flange, four ball guide grooves

Shaft diameter
6–10 mm
Hardened and ground outer sleeve, plastic ball retainer



Compact Linear Set R0723.., flanged

Shaft diameter
12–50 mm

Steel compact outer sleeve or flanged sleeve, Torque-Resistant Compact Linear Bushing, precision steel shaft with ball guide groove



Torque-Resistant Linear Bushing R0725.., flanged, four ball guide grooves with four ball guide grooves

Shaft diameter
6–50 mm
Hardened and ground outer sleeve, plastic ball retainer

Unsupported Linear Bushings and Shafts – with closed-type Linear Bushings

Linear Bushings for combined linear and rotary motion



Linear Bushing R0664... with deep-groove ball bearing, Series 60

Shaft diameter
5–80 mm
Maintenance-free, sealed with shields, Standard or Segmental Linear Bushing, external seals or integrated wiper seals



Linear Bushing R0663... with deep-groove ball bearing, Series 618

Shaft diameter
5–80 mm
Standard or Segmental Linear Bushing, external seals or integrated wiper seals



Linear Bushing with needle bearing R0665... without wiper seals R0667... with wiper seals

Shaft diameter
5–80 mm
Standard Linear Bushing, steel spacer rings, retaining rings

Torque-Resistant Linear Bushings for combined linear and rotary motion



Torque-Resistant Linear Bushing R0727... with four ball guide grooves

Shaft diameter
20–40 mm
Hardened and ground outer sleeve, integrated wiper seals, integrated cross-roller bearing

For conversion of linear to rotary motion with one Linear Bushing.
Linear motion with torque transmission.

Supported Linear Bushings and Shafts – with open-type Linear Bushings

Standard Linear Bushings and Linear Sets



Robust, hard-wearing design, particularly suitable for tough demands.

Can be used at temperatures up to 200 °C without seals.

Standard Linear Bushing open
R0630.., without wiper seals
R0632.., with two wiper seals

Shaft diameter
 12–80 mm

Hardened and ground outer sleeve, steel ball retainer, wiper seals or integrated steel holding rings



Linear Set
R1067.., open
R1068.., open, adjustable

Shaft diameter
 20–80 mm

Spheroidal graphite cast iron/steel precision housing, Standard Linear Bushing with two wiper seals, retention with locating screw



Linear Set
R1071.., with side opening
R1072.., with side opening, adjustable

Shaft diameter
 20–50 mm

Aluminum precision housing (lightweight design), Standard Linear Bushing with two external seals, retention with grooved taper pin

Supported linear bushings and shafts – with open-type linear bushings

Super Linear Bushings and Linear Sets

Unbeatably smooth ball circulation, self-alignment feature, hardened and ground steel bearing plates with ball guide grooves.

A, **H**, **SH** = Super Linear Bushing **with** self-alignment up to $30' = 0.5^\circ$ (Series H and SH are especially suited for applications with higher loads and durability requirements as a result of the increased number of steel bearing plates.)

B = Super Linear Bushing **without** self-alignment

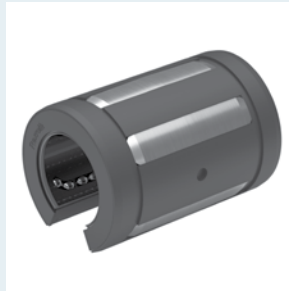

Super Linear Bushing **A R0671.., open, self-aligning**

Shaft diameter 12–50 mm
With or without two integrated wiper seals, or with two integrated wiper seals and side seals (fully sealed)



Linear Set R1037.., open

Shaft diameter 12–50 mm
Aluminum precision housing (lightweight design), with Super Linear Bushing **A** or **B**, relubricatable



Linear Set R1071.., with side opening

Shaft diameter 20–50 mm
Aluminum precision housing (lightweight design), with Super Linear Bushing **A** or **B**, relubricatable, with two wiper seals and side seals (fully sealed)



Super Linear Bushing **B R0673 open, non-self-aligning**

Shaft diameter 12–50 mm
With or without two integrated wiper seals, or with two integrated wiper seals and side seals (fully sealed)



Linear Set R1038.., open, adjustable

Shaft diameter 12–50 mm
Aluminum precision housing (lightweight design), with Super Linear Bushing **A** or **B**, relubricatable



Linear Set R1072.., with side opening, adjustable

Shaft diameter 20–50 mm
Aluminum precision housing (lightweight design), with Super Linear Bushing **A** or **B**, relubricatable, with two wiper seals and side seals (fully sealed)



Linear Set R1087.., tandem, open

Shaft diameter
12–50 mm

Aluminum precision tandem housing (lightweight design), two Super Linear Bushings , relubricatable, two external seals



Linear Set R1067.., open

Shaft diameter
12–50 mm

Spheroidal graphite cast iron/steel precision housing, retention with locating screw, Super Linear Bushings , integrated wiper seals and side seals (fully sealed)



Super Linear Bushing  R0733.., open, self-aligning

Shaft diameter
20–60 mm



Hardened steel bearing plates with ground ball tracks. With or without two integrated wiper seals



Linear Set R1703.., open

Linear Set R1704.., Open, adjustable

Shaft diameter
20–60 mm

Aluminum precision housing (lightweight design), with Super Linear Bushing  or , relubricatable



Linear Set R1034.., open, adjustable

Shaft diameter
12–50 mm

Aluminum precision tandem housing (lightweight design), two Super Linear Bushings , relubricatable, two external seals



Linear Set R1068.., open, adjustable

Shaft diameter
12–50 mm

Spheroidal graphite cast iron/steel precision housing, retention with locating screw, Super Linear Bushings , integrated wiper seals and side seals (fully sealed)



Super Linear Bushing  R0731.., open, self-aligning



Shaft diameter
20–50 mm

Hardened steel bearing plates with ground ball tracks. With or without two integrated wiper seals



Linear Set R1706.., with side opening, adjustable

Shaft diameter
20–50 mm

Steel precision housing, retention with locating screw, Super Linear Bushings  or , integrated wiper seals and side seals (fully sealed)

Precision steel shafts and Shaft Support Blocks

Characteristic features

- ▶ **Broad application spectrum** with shafts in various tolerances made of heat-treated steel and corrosion-resistant steel as well as hard chrome plated
- ▶ **Induction hardened** and ground, available as solid or tubular shafts
- ▶ **Customized end machining to customer specification** with internal thread on end face, undercuts for retaining rings, spigots, threaded spigots, key flats, annealed ends for further machining or with other processing options
- ▶ Shafts in mill-cut lengths for individual machining, **cut to desired length** with chamfering at both ends or machined to specification
- ▶ Shafts available in **Linear Bushing and other diameters**



Precision steel shaft, solid R1000..



Precision steel shaft, tubular R1001..



Precision steel shaft R0724 0, solid, with four ball guide grooves



Precision steel shaft R0724 0, tubular, with four ball guide grooves



For steel shafts with one or two ball guide grooves, see Torque-Resistant Linear Bushings

Precision steel shafts

Shaft diameter
3–110 mm

Linear Bushing diameters:

3, 4, 5, 8, 10, 12, 14, 16, 20, 25, 30, 40, 50, 60, 80 mm

Other diameters:

6, 15, 18, 22, 24, 32, 35, 38, 45, 55, 70, 100, 110 mm

Compact Shaft Support Blocks R1058..

Shaft diameter
12–50 mm

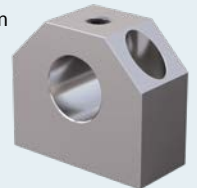

Shaft Support Blocks R1057..

Shaft diameter
10–60 mm

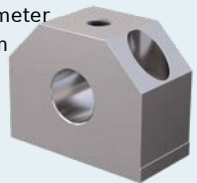

Shaft Support Blocks R1055..

Shaft diameter
8–80 mm

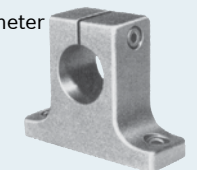

Shaft Support Blocks R1056.., flanged

Shaft diameter
12–50 mm



Examples of shaft end machining
Machining to customer specifications



Steel shafts with ready-mounted Shaft Support Rails and Shaft Support Rails



Steel shaft with flange R1010.., with mounted Shaft Support Rail

Steel shaft for aluminum framing systems R1025.., with mounted Shaft Support Rail

Shaft diameter
16–40 mm

High rigidity, aluminum, low-cost



Steel shaft R1011.., aluminum, mounted with Shaft Support Rail

Shaft diameter
12–50 mm

High rigidity, very accurate height tolerance



Steel shaft with flange R1014.., with mounted Shaft Support Rail, aluminum

Shaft diameter
12–80 mm

High rigidity, very accurate height tolerance



Side-mount steel shaft R1015.., with mounted Shaft Support Rail, aluminum

Shaft diameter
20–50 mm

High rigidity, Type 1 (standard) or Type 2 (customized hole pattern)



Steel shaft R1013.., with mounted Shaft Support Rail, aluminum, flanged

Shaft diameter
12–30 mm

Steel shaft R1016.., with mounted Shaft Support Rail, steel, flangeless

Shaft diameter
16–50 mm



Shaft Support Rail R1039.., aluminum, drilled, for aluminum framing systems
Shaft Support Rail R1039.., aluminum, undrilled

For shaft diameter
20–30 mm



Shaft Support Rail R1050.., Aluminum, flanged, drilled
Shaft Support Rail R1050.., aluminum, flanged, undrilled

For shaft diameter
12–80 mm,
length 600 mm



Side-mount Shaft Support Rail R1054.., aluminum

For shaft diameter
20–50 mm,
available in Type 1 (standard) or Type 2 (customized hole pattern)

Powerful components for building tailor-made solutions

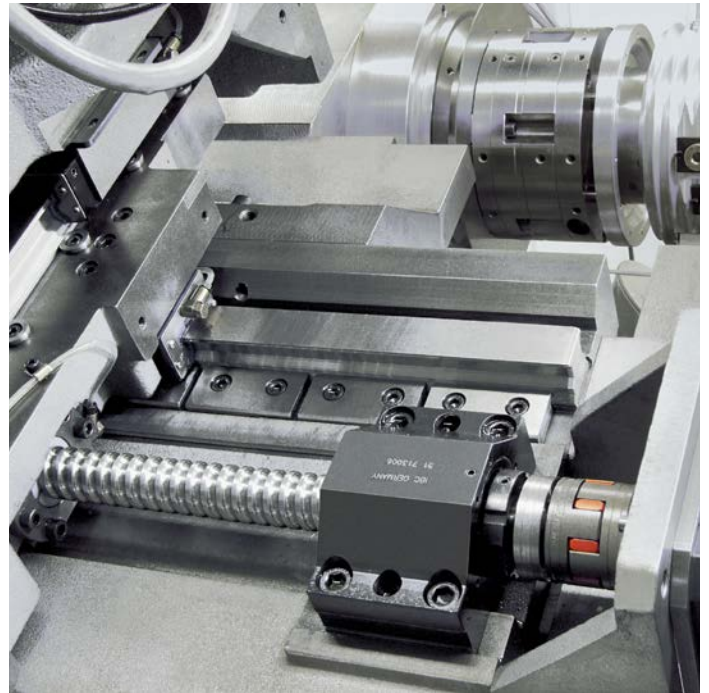
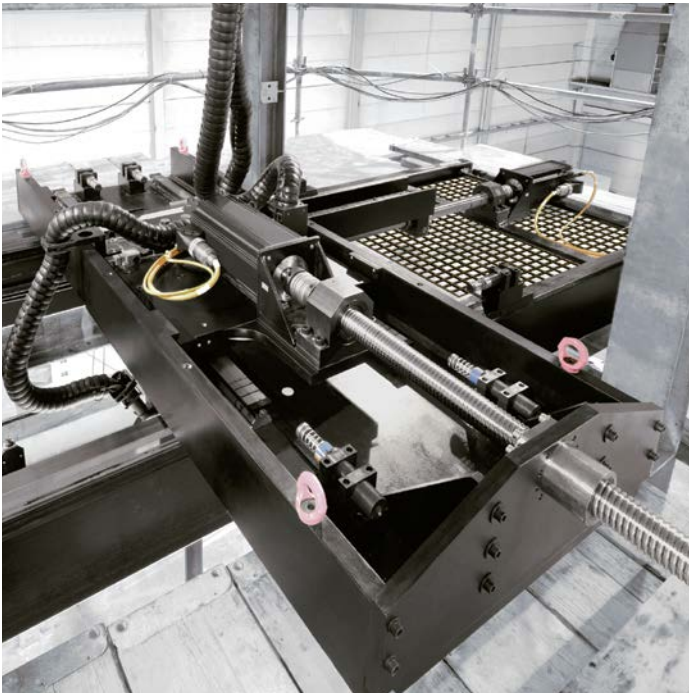

Ball Screw Drives are the efficient solution for precise conversion of rotary to linear motion. Based on long years of experience and deep engineering expertise, we have developed a product line-up that satisfies even the most diverse requirements. No matter whether you are looking for highest linear speeds, maximum load ratings or minimal installation lengths, you will find the ideal solution within our manufacturing range.

Speed limits and characteristic speed $d \cdot n$

The bearing speed, critical bending speed of the screw and the characteristic speed $d \cdot n$ of the ball nut can restrict the linear speed.

The $d \cdot n$ value of 150,000 in our specifications is based on tests performed under particularly harsh conditions, with a thermal load of 60 °C and a travel of 300 million revolutions. This corresponds to the life expectancy of a Ball Screw Drive operating at a load of $0.15 \cdot C$ – practical and proven, as you would expect from Rexroth!

Characteristic features

- ▶ **Broad diversity**, a match for every requirement
- ▶ Absolutely **consistent** and **stable functioning**
- ▶ **Especially smooth running** due to optimized ball pickup and recirculation
- ▶ **High load ratings** due to large number of balls
- ▶ **Short ball nut design**
- ▶ **Easy-to-mount** nuts; mounting orientation per customer specification
- ▶ **Adjustable** pre-tensioned **Single Nuts**
- ▶ **Extensive range** with various series in stock
- ▶ **Perfectly matched additional single components** such as Nut Housings, end bearings, also as Pillow Block Units, including pre-machined versions for attachment of suitable motor mounts



Lifelong lubrication with Front Lube Unit

The Front Lube Unit (VSE) has been designed for the long-term, maintenance-free operation of the ball screw assembly. It is attached to the nut and delivers lube oil continuously to the rolling elements. For traveling up to 300 million revolutions without relubrication.

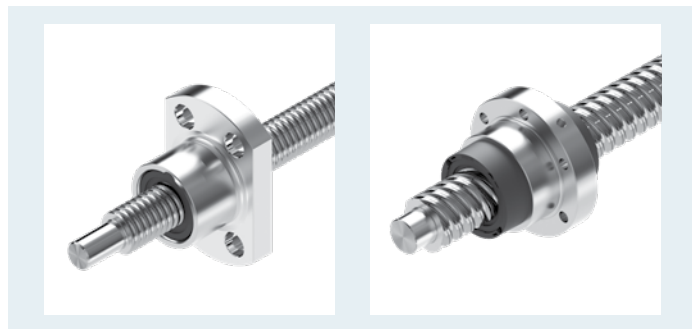
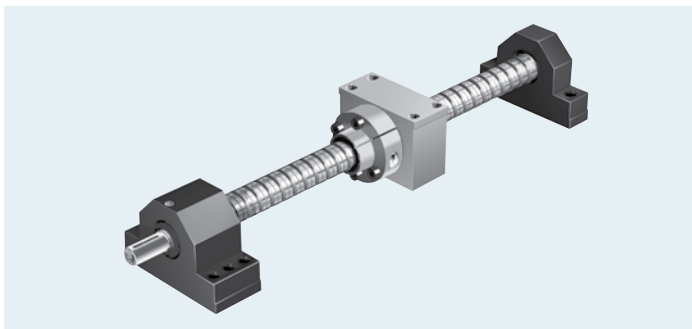

Perfectly tuned solutions

To achieve solutions offering maximum accuracy and operating reliability, the individual components in our range have been engineered to interact precisely with each other. They can be used to efficiently create complete units. You can also find the right drive motors and flange elements at Rexroth.

Miniature/Speed Series

The ideal product lines for economic implementation of positioning and transport applications. Pre-assembled with nuts in screw-in or flanged designs, these series provide simple and quick solutions.

Single Nuts

Standard series

Most nut types available with Front Lube Unit. All nuts are coated with anti-corrosion oil prior to shipment. Complete Ball Screw Drives come pre-lubricated. Several seal versions available.



Single Nut with flange FEM-E-D
 Sizes 20x5R-80 x 20R
 With backlash or reduced backlash, various preload classes



Double Nut with flange FDM-E-D
 Sizes 20x5R-80x20R
 Various preload classes, only available as complete ball screw drive



Single Nut with flange FEM-E-S
 Sizes 8x2.5R-80x20R
 Left-handed thread also available, with backlash or reduced backlash, various preload classes



Single Nut with flange FEM-E-C
 Sizes 16x5R-80x20R
 Left-handed thread also available, with backlash or reduced backlash, various preload classes



Single Nut with flange and recirculation cap FSZ-E-S
 Sizes 20x5R-40x20R
 With backlash or reduced backlash, various preload classes



Adjustable-preload Single Nut SEM-E-C
 Sizes 16x5R-80x20R
 Adjustable preload



Double Nut with flange FDM-E-S
 Sizes 16x5R-80x20R
 Various preload classes, only available as complete ball screw drive



**Double Nut with flange
FDM-E-C**

Sizes 16x5R–80x20R

Various preload classes, only available as complete Ball Screw Drive



**Cylindrical Single Nut
ZEM-E-S, ZEM-E-A, ZEM-E-K**

Sizes 8x2.5R–80x10R

Left-handed thread also available, with backlash or reduced backlash, various preload classes



**Adjustable-preload Single
Nut SEM-E-S**

Sizes 8x2.5R–80x20R

Adjustable preload, left-handed thread also available



Screw-in Nut ZEV-E-S

Sizes 12x5R–32x10R

With backlash or reduced backlash, various preload classes

Single Nuts

High-Performance, Miniature and Speed Series

Most nut types available with front lube unit. Nuts are coated with anti-corrosion oil prior to shipment.
Complete Ball Screw Drives come pre-lubricated.
Several seal versions available.



Two-start Single Nut with flange FED-E-B

Sizes 16 x 16R–63 x 40R

High-Performance Series

For significant increase in load ratings, with backlash or reduced backlash, various preload classes, only available as complete Ball Screw Drive



Miniature flanged Single Nut FEM-E-B

Sizes 6 x 1R–12 x 10R

Miniature Series

With backlash or reduced backlash, various preload classes, only available as complete ball screw drive



Driven nut FAR-B-S

Sizes 32 x 10R–63 x 40R

High-Performance Series

Various preload classes, only available as complete ball screw drive



Single Nut with flange and recirculation caps FEP-E-S

Sizes 20 x 40R–32 x 64R

Speed Series

With backlash or reduced backlash, various preload classes, plastic recirculation cap, only available as complete ball screw drive

Nut Housings, Precision Screws

Nut Housings

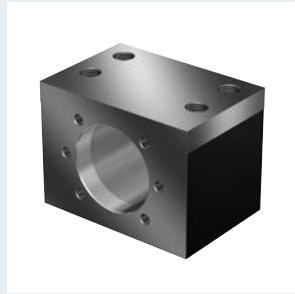

Nut Housing MGD
Sizes 16 x 5R–80 x 20R

Nut Housing MGS
Sizes 16 x 5R–80 x 10R
Steel Nut Housing, reference
edges on both sides

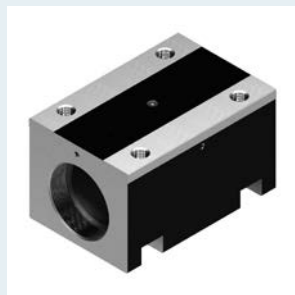

Nut Housing MGA
Sizes 20 x 5R–40 x 40R
Aluminum Nut Housing,
reference edges on both
sides

Precision Screws



Our rolled Precision Screws are a key component in our Ball Screw Drives and are available in many sizes and pitches. Depending on the lead, our screws can also be delivered in two-start or four-start versions. In combination with our multi-start nuts, this allows higher load ratings to be achieved within a short overall length.

Accuracy classes T3, T5, T7, T9

Sizes 6–80 mm

Lead 1–64 mm

Max. C = 315 kN (dynamic)

Max. C0 = 534 kN (static)

Lengths up to 13 m available

Screw ends, end bearings

Screw ends and end bearings

Offering a variety of different shaft end machining variants, including processing to your own specifications, our shaft ends combined with appropriate end bearings from our range fulfill all the requirements for your specific application. From deep-groove ball bearing to complete Pillow Block Unit – the screws and end bearings in our portfolio are always matched perfectly to provide optimum performance. They are essential to trouble-free functioning and reliable operation of processes.

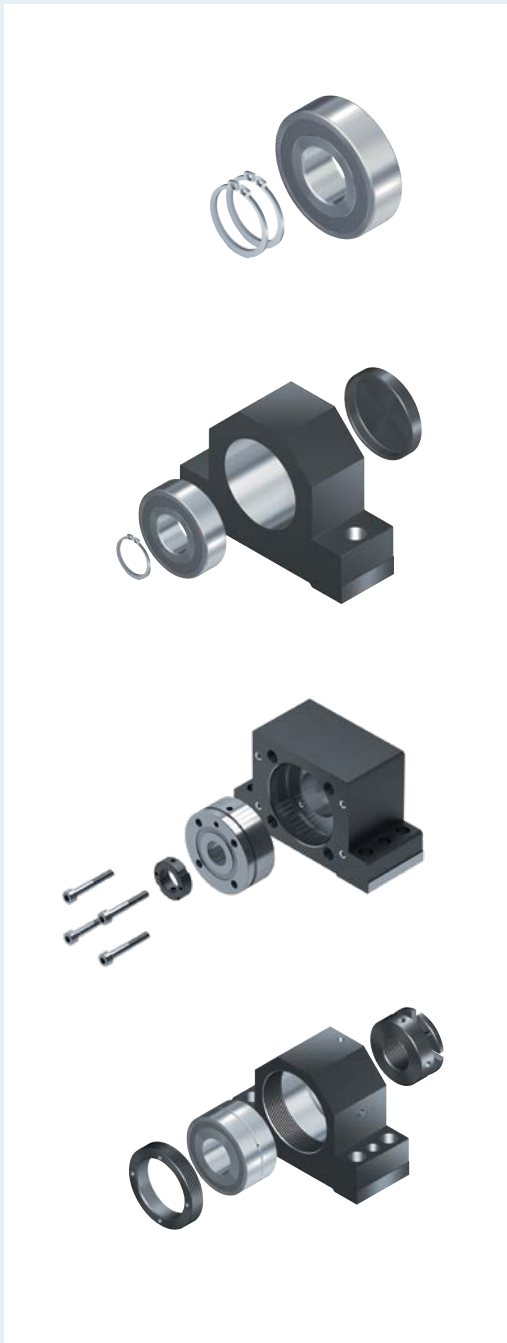

Bearings, Slotted Nuts and Threaded Rings

Bearings

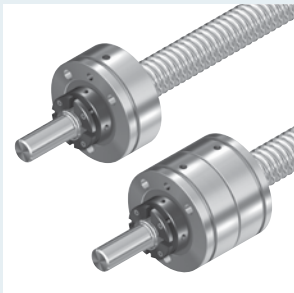

Bearing LAF
Fixed bearing with angular-contact thrust ball bearing, double-thrust, screw-down, with Slotted Nut

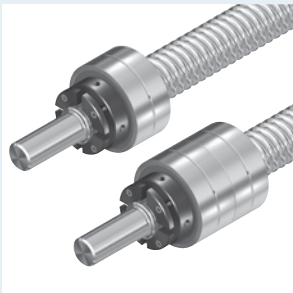

Bearing LAN
Fixed bearing with angular-contact thrust ball bearing, double-thrust or double-thrust in pairs, with Slotted Nut

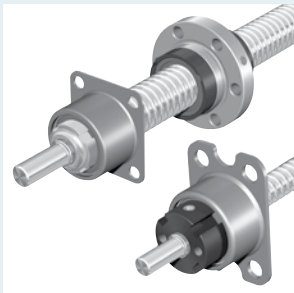

Bearing LAL
Fixed bearing with angular-contact thrust ball bearing, double-thrust, screw-down, for economical constructions, with Slotted Nut

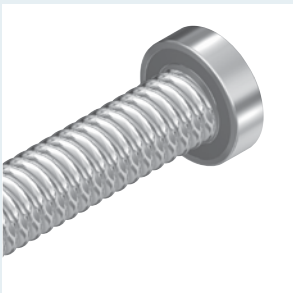

Bearing LAD
Floating bearing with deep-groove ball bearing and retaining ring

Slotted Nuts and Threaded Rings

With so many different subassembly designs, there obviously has to be a corresponding variety of Slotted Nuts and Threaded Ring. For applications involving high vibrations or for economical constructions – Rexroth will always have the perfect solution for you.

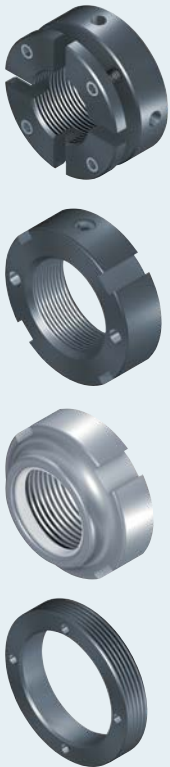

Pillow Block Units

Pillow Block Units

Good solutions are a matter of attention to detail. Our Pillow Block Units and bearings are precision-engineered and manufactured products that have proven themselves in the field over many years. Designed to meet any requirements, they provide the exact performance range necessary. From a complete Pillow Block Unit to economic fixed or floating bearings.

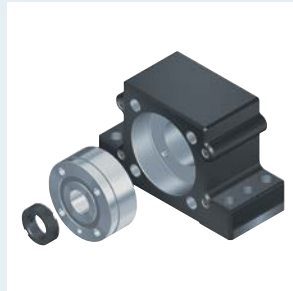

Pillow Block Unit SEC-F
Aluminum

Fixed bearing with angular-contact thrust ball bearings, **aluminum** precision Pillow Block Housing with reference edge on both sides, angular-contact thrust ball bearing with Slotted Nut, motor mountings can be directly adapted



Pillow Block Unit SES-F
Steel

Fixed bearing with angular-contact thrust ball bearings, **steel** precision Pillow Block Housing with reference edge on both sides, angular-contact thrust ball bearing with Slotted Nut, motor mountings can be directly adapted

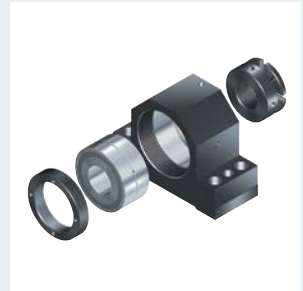

Pillow Block Unit SEB-F
Steel

Fixed bearing with angular-contact thrust ball bearings, **steel** precision Pillow Block Housing with reference edge on both sides, angular-contact thrust ball bearing with Slotted Nut and Threaded Ring

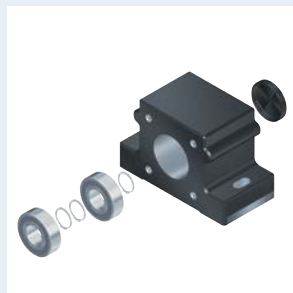

Pillow Block Unit SEC-L
Aluminum

Floating bearing with deep-groove ball bearing, **aluminum** precision Pillow Block Housing with reference edge on both sides, deep-groove ball bearing with retaining ring and cover



Pillow Block Unit SES-L
Steel

Floating bearing with deep-groove ball bearing, **steel** precision Pillow Block Housing with reference edge on both sides, deep-groove ball bearing with retaining ring and cover

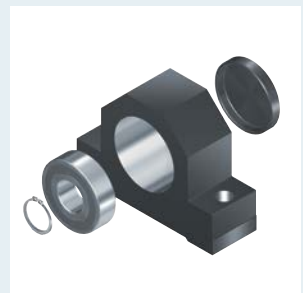

Pillow Block Unit SEB-L
Steel

Floating bearing with deep-groove ball bearing, **steel** precision Pillow Block Housing with reference edge on one side, deep-groove ball bearing with retaining ring and cover



Pillow Block Unit SED-F-Z
Steel

Fixed bearing with angular-contact thrust ball bearing, **steel** precision Pillow Block Housing, pre-tensioned angular-contact thrust ball bearing, Slotted Nut, cover and radial shaft wiper seal



Flanged Bearing SEE-F-Z
Steel

Fixed bearing with angular-contact ball bearing, **steel** precision flanged housing, pre-tensioned angular-contact thrust ball bearing, Slotted Nut, cover and radial shaft wiper seal



Pillow Block Unit SED-L
Steel

Deep-groove ball bearing, steel Pillow Block Housing, pre-tensioned deep-groove thrust ball bearing and retaining ring

Planetary Screw Assemblies – more compact, powerful, and quiet



Rexroth has enhanced the range of applications for its Screw Drives to include the quick movement of heavy loads with all-new Planetary Screw Assemblies PLSA. The series consists of cylindrical nuts, nuts with flanges, and screws with various diameters and leads. Dynamic load ratings up to 544 kN and static load ratings up to 1,496 kN combined with more compact dimensions and lower noise levels allow for a wide range of current and new applications.

Combining a PLSA with a servo motor produces a mechatronic unit with the nominal force of a hydraulic cylinder. Ultra-high accuracy, positioning, and flexibility as well as low energy consumption lend the design to being used as a feed axis in modern servo presses, machines tools, and injection molding machines.

Characteristic features

- ▶ **High load-bearing capacity** thanks to numerous, large contact surfaces
- ▶ **Quiet running** due to guided planets
- ▶ **Compact size** as a result of improved power density
- ▶ **Lower consumption of lubricants and good environmental protection** via effective seals
- ▶ **Different nut types** available
- ▶ **Economic solution** realized by rolled spindle

Single Nuts and bearings

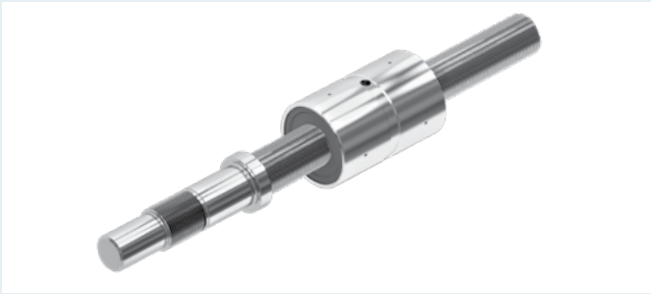

Cylindrical Single Nut with backlash ZEM-E-S

Sizes 20x5R–75x20R

With standard seals, max. backlash 0.03 mm, for Precision Screws PSR in tolerance grades T5, T7, T9, static load ratings up to 1,496 kN, dynamic load ratings up to 544 kN



Single Nut with flange and backlash FEM-E-S

Sizes 20x5R–75x20R

With standard seals, max. backlash 0.03 mm, for Precision Screws PSR in tolerance grades T5, T7, T9, static load ratings up to 1,496 kN, dynamic load ratings up to 544 kN



Split flange Single Nut with preload FDM-E-S

Sizes 20x5R–60x20R

With standard seals, preloaded, for Precision Screws PSR in tolerance grades T5, T7, static load ratings up to 393 kN, dynamic load ratings up to 218 kN



Bearing LAS

Fixed bearing support with angular-contact ball bearing, double direction, with Slotted Nut



Bearing FEC-F

Fixed bearing with angular-contact ball bearing with steel precision flanged housing and Slotted Nut

Linear Motion Axes – compact units for diverse applications

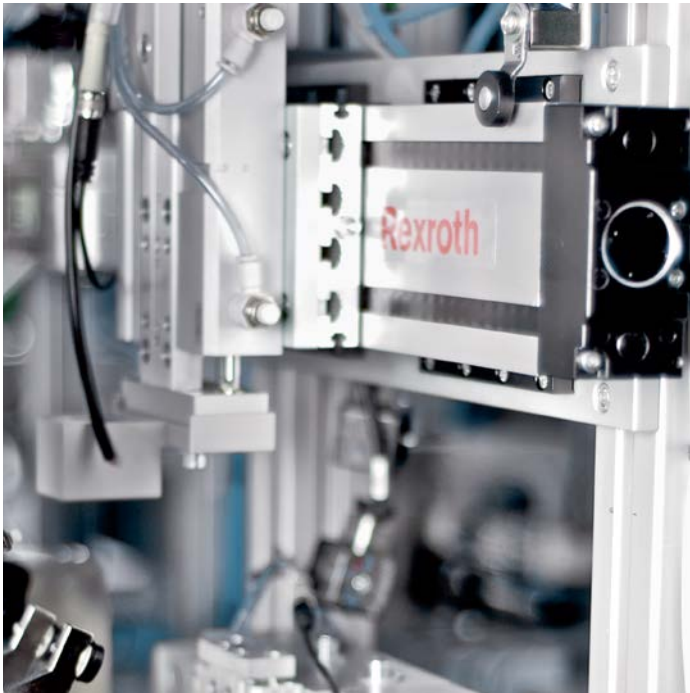

Photo: VS Engineering SRL - Ettore Franceschi



Our Linear Motion Systems range from single axes to sophisticated, pre-configured complete solutions precisely engineered to meet your specific requirements and application needs – compact and ready to install.

They help you to get ahead faster, more easily and much more efficiently. You benefit above all from our extensive know-how in guidance technologies and the development and manufacturing expertise we have built up in this area over many years. This, together with our special steel bearing plate technology and the housings we make ourselves, is the reason we are able to minimize the size of our modules. In terms of performance-to-volume ratio, our Linear Motion Axes are unbeatable, to say nothing of their high precision and quality. This naturally holds true for cleanroom applications as well, and appropriate certifications have been obtained. Since use in these areas depends on many different factors, please contact our specialists for more information.

Characteristic features

- ▶ **Complete product range** for assembly and handling systems, as standard solutions or individually adaptable for use in almost any industry
- ▶ **Scalable and ready-made Linear Motion Systems**
- ▶ **Extremely cost-effective**, since the customer no longer has to match up the guide and the drive element
- ▶ **Reduced** design and manufacturing effort due to high degree of standardization
- ▶ **Extensive range** of attachments and accessories
- ▶ **Configuration** with motor attachment, drive amplifier and control unit to produce complete systems
- ▶ **Adaptations** to customer requirements
- ▶ **Excellent service** provided by experienced specialists

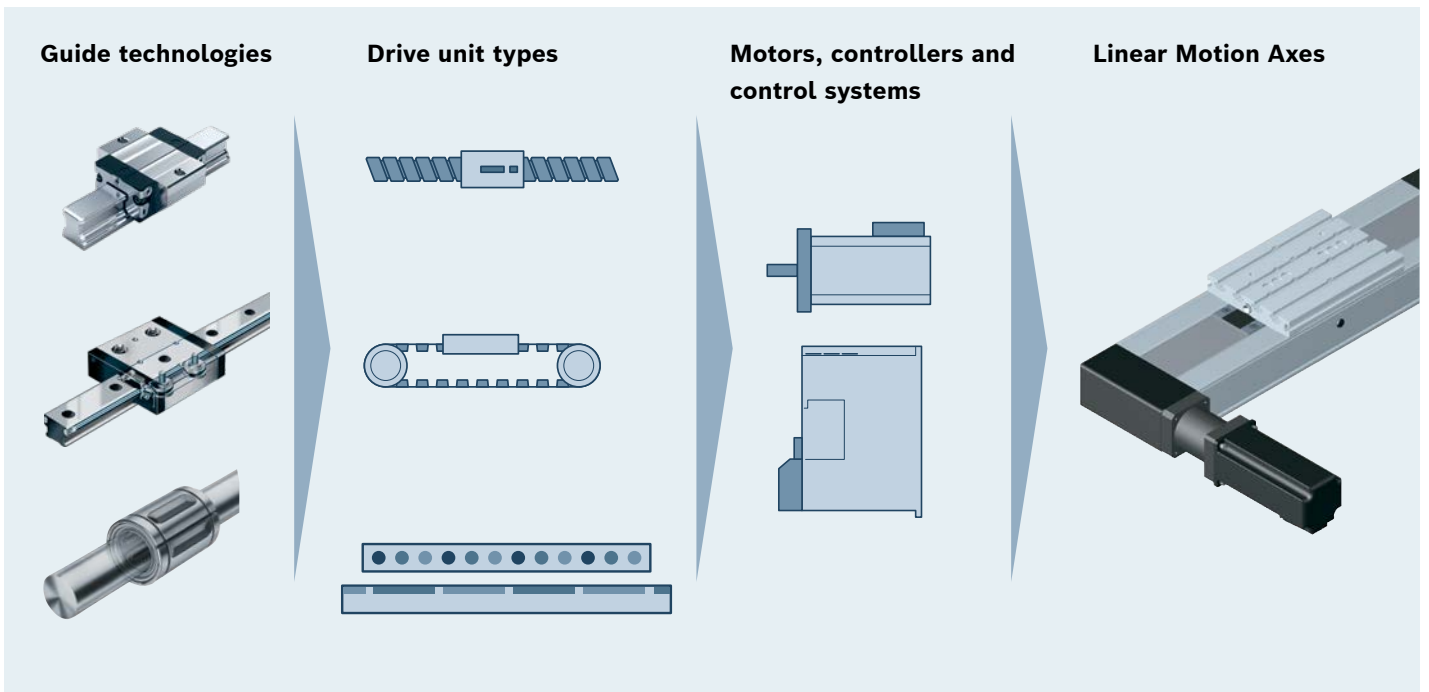

Guide technologies
 In our Linear Motion Axes, we integrate guide components in the following designs:

Ball Rail Systems
 Very high rigidity and accuracy, speed up to 5 m/s

Cam Roller Guides
 Unbeatable dynamics and speeds up to 10 m/s, extremely low-noise operation

Linear Bushings and Shafts
 Smooth-running and robust, especially for harsh environments

Drive types
 The characteristics of the Linear Motion Axes are essentially determined by the type of drive unit used.

Ball Screw Drives
 High rigidity, high power density and repeatability

Belt drive
 For long travel distances with high dynamics, maintenance-free

Linear motor
 For high travel speeds and high acceleration, fast cycling, highly accurate positioning, maintenance-free

Motors, controllers, control units
 Our portfolio also includes motors, controllers and control systems for configuring Linear Motion Axes into complete Linear Motion Systems. With our long experience, we make sure the combinations are designed to maximize process efficiency.

Linear Motion Axes
 All of our Linear Motion Systems are optimally engineered to serve the requirements of each specific industry. From solutions with maximum possible standardization to systems specially adapted to meet your needs and specifications, we develop systems that deliver perfect results.

Drive Units

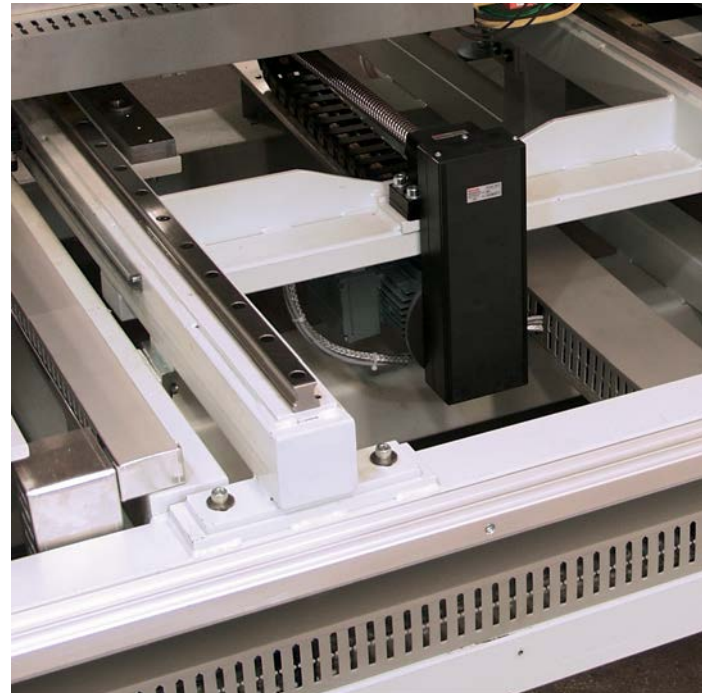

Drive Units AOK and AGK consist of a proven Rexroth Ball Screw Drive with Nut Housings and Pillow Block Units to make it into a ready-to-install drive axis. When combined with an external linear guide, the Drive Unit becomes a functional Linear Motion Axis for numerous applications.

Characteristic features

- ▶ Available in three sizes for any length up to 5,600 mm
- ▶ Variable length and features thanks to extensive options
- ▶ Technical data provided for complete unit, e.g., maximum drive torque, speed, etc.
- ▶ Nameplate with technical parameters for start-up
- ▶ High positioning accuracy and repeatability thanks to Ball Screw Drive with zero-backlash, pre-tensioned nut system
- ▶ Together with Rexroth Rail Systems, you get all the design freedom you need to build a machine.

Driven-screw Drive Units



Open Drive Unit AOK

Open Drive Units AOK are ready-to-install drive axes consisting of Ball Screw Drive with Nuts and Pillow Blocks, with optional Nut Housings

- ▶ Three coordinated sizes in any length up to L_{max} .
- ▶ A version with fixed and floating bearing as well as fixed bearing only is available
- ▶ Driven by precision-rolled Ball Screw Drive in accordance with DIN 69051
- ▶ Screws available in tolerance grade T5 or T7
- ▶ Various nut versions optional depending on size and lead
- ▶ Three different preloads available (C1, C2 and C3)
- ▶ Aluminum or steel Pillow Blocks available
- ▶ High traversing speeds thanks to large leads with high precision over long lengths
- ▶ Nuts can be optionally selected with Front Lube Unit for longer lubrication intervals



Closed Drive Unit AGK

Closed Drive Units AGK are ready-to-install drive axes consisting of Ball Screw Drive, Nut Housings and Pillow Blocks enclosed in a protective aluminum profile with cover strip

- ▶ Three coordinated sizes in any length up to L_{max} .
- ▶ The Ball Screw Drive is perfectly protected by the profile and steel or polyurethane sealing strip
- ▶ Driven by zero-backlash, pre-tensioned, rolled, precision Ball Screw Drive in accordance with DIN 69051 in tolerance grade T5 or T7
- ▶ High traversing speeds thanks to large leads with high precision over long lengths
- ▶ Optional traveling screw supports for maximum speed over long lengths for use in horizontal mounting positions

Ball Rail Tables

With our Ball Rail Tables TKK, Rexroth offers ready-to-install solutions for linear motion and positioning tasks requiring high accuracy and rigidity. Their compact design, with pre-tensioned Rail Systems and Ball Screw Drive, allow for high-precision travel with high rigidity. The accuracy charts in the catalog illustrate the precision of these compact Linear Motion Axes. In order to be able to implement the best and most affordable total solution for any customer application, matching Rexroth motors are available that can be mounted by flange and coupling or on a timing belt side drive.

Other accessories include optional switches that can be installed to be protected on the inside while remaining freely accessible on the outside.

Characteristic features

- ▶ Ball Rail Tables TKK are **ready-to-install Linear Motion Axes** and available **in two versions**
 - Aluminum: aluminum profile base plate and carriage
 - Four coordinated sizes in finely graduated length increments up to L_{max}
 - Steel: steel base plate and carriage
 - Two coordinated sizes in finely graduated length increments up to L_{max}
- ▶ **Quick installation and easy alignment** thanks to the machined base plate with reference edge
- ▶ **High travel accuracy, positioning accuracy and repeatability**
- ▶ Base plate with two Ball Rail Systems and carriage with four Runner Blocks, plus central Ball Screw Drive for:
 - **Optimal travel**
 - **Very smooth running**
 - **High rigidity**
 - **High load ratings and load moments**
- ▶ Driven by **zero-backlash, pre-tensioned, rolled, precision Ball Screw Drive** in accordance with DIN 69051 in tolerance grade T7
- ▶ **The Guide Rail and Ball Screw Drive are optimally protected** thanks to a polyurethane boot

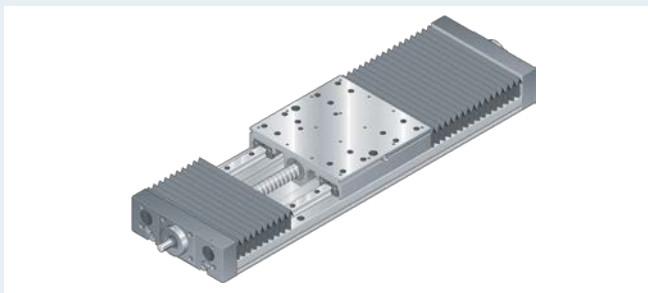

Ball Rail Table TKK

For moderate to very heavy loads.

The performance capability and design of a Ball Rail Table is determined by the weights which have to be moved and the travel distance, the required rigidity and the environmental conditions. Solve your linear motion challenges in a wide range of applications with speed and precision with Ball Rail Tables TKL. The coordinated system of synchronous linear motor, Ball Rail System, position measuring system and carriage significantly reduce the typically high costs of designing a Linear Motion Axis. Since no mechanical transmission elements are necessary to convert rotary motion into linear motion, the Ball Rail Tables TKL offer zero-backlash drive.

Characteristic features

- ▶ **Easy installation and application:** completely integrated linear motor system as a ready-to-install solution for design engineers.
- ▶ **High speed and acceleration:** synchronous direct linear drive. High overload factor and high dynamics are possible.
- ▶ **Precise movement and high dynamics over the entire service life:** Thrust is generated directly on the load. There is no mechanism converting rotary to linear motion, no transmission for high rigidity. Linear, high-resolution position measuring system.
- ▶ **Extreme load cycles are possible:** Excellent heat dissipation through liquid cooling of the primary part.
- ▶ **Easy maintenance:** Little maintenance effort



Ball Rail Table TKL

Specially suited for applications requiring both **high dynamics** and **excellent positioning**.

required due to the low-wear direct drive and the easy-to-maintain guide system.

Further highlights

- ▶ Openly configurable thanks to a variety of options
- ▶ Extremely compact precision aluminum profile with fly-cut rail seat, reference edge, and base area for optimal travel
- ▶ The Ball Rail Systems are easy to maintain due to the central lube port on each side of the carriage
- ▶ Built-in elements are protected by high-quality, welded high-speed bellows resistant to oil and moisture
- ▶ Clamping element is optional
- ▶ Ball Runner Block in a high-precision design

Precision modules

In addition to their outstanding performance features and small dimensions, our precision modules feature superior accuracy.

The compact size and rigidity are achieved through highly-precise steel profiles on the main structure with integrated Rexroth guide tracks. Equipped with high-quality Ball Screw Drives with backlash-free nut systems, these modules achieve exceptionally high positioning accuracy and repeatability in tolerance grade 7 – and at high travel speeds.

Characteristic features

- ▶ **High-precision** linear modules with **steel profile frames in very compact dimensions**
- ▶ Running tracks ground into the frame, **extremely close manufacturing and mounting tolerances**
- ▶ **Travel performance** with high load capacity, precision and rigidity
- ▶ **Extremely high positioning accuracy and** repeatability thanks to backlash-free nut system
- ▶ **High travel speeds** due to double floating bearing, large screw diameters and leads
- ▶ **Rapid mounting and easy axis alignment** thanks to machined reference edge on the frame



Precision Modules PSK

Three different series: open modules or modules with cover plate or cover strip of corrosion-resistant steel per EN 10088. **Four sizes in different lengths up to 940 mm.**

The modules are available with one or two steel carriages, standard length or long. Switches adjustable over the entire travel range.

Compact modules

In many applications, space is a major problem. The challenge here is to nevertheless achieve high performance with optimal travel characteristics, high ratings, high rigidity and precision. This is where our compact modules score with their excellent performance data, including unsurpassed torque load. They are configured as ready-to-install, plug-and-play units. Center holes in the frame and carriage make combining modules not only easier, but precise and secure. To prevent downtime due to neglected maintenance or incorrect lubricant, Rexroth has designed its ready-to-install compact modules to connect to one-point lubrication systems for increased machine availability.

Characteristic features

- ▶ **Especially low profile** thanks to compact design with built-in Guide Rails and Runner Blocks integrated in the carriage.
- ▶ **Steel bearing plate technology** permits the use of **aluminum carriages** to reduce the moved mass
- ▶ **High travel speeds** combined with high precision and smooth running
- ▶ **High torque load** due to twin Guide Rails
- ▶ **High power density** in terms of load-bearing capacity and overall dimensions
- ▶ **Compact aluminum frame** with excellent intrinsic rigidity
- ▶ **Minimized maintenance effort** due to one-point lubrication connection



Compact Module CKK with Ball Screw Drive

Extremely compact precision-extruded aluminum profile (frame) with two integrated Ball Rail Systems. Precision Ball Screw Drive in tolerance grade 7 with zero-backlash nut system.

Available in five sizes up to a length of 2,200 mm, with screw support up to 5,500 mm.

With traveling gap seal made of polyurethane tape reinforced with steel cords.



Compact Module CKR with belt drive

Extremely compact precision-extruded aluminum profile with two integrated Ball Rail Systems.

Available in five sizes in lengths up to 10,000 mm.

Aluminum carriage in two different lengths to accommodate different loads. Idler end enclosure with integrated belt-tensioning system. Pulley ball bearings are lubricated for life. High travel speeds combined with high precision and smooth running. The belt also acts as a gap seal and is guided laterally by aluminum strips.

Linear modules

Powerful Linear Motion Axes as precise, ready-to-install linear motion systems that combine high performance with compact dimensions – these are the key attributes of our linear modules. With their high load ratings, optimal travel characteristics and combinability with different drive types, the integrated, zero-backlash guide systems make it possible to implement specific requirements, especially for moving large masses at high speeds.

For automation and handling tasks, in particular, our ready-to-install modules offer distinct advantages over customer-built designs made up of single components. With a configured linear module, you obtain a standard solution that has proven its worth many times over in practice. Naturally, each solution can be provided with add-ons to meet individual needs.

Characteristic features

- ▶ **Precise, ready-to-mount guide systems with high performance characteristics and compact dimensions**
- ▶ **Extremely compact aluminum frame** with excellent rigidity and integrated Cam Roller Guides or Ball Rail Systems
- ▶ Powerful **belt** drives or Ball Screw Drives for reliable movement
- ▶ **High rigidity, therefore suitable for self-supporting installation**
- ▶ Available **with gear reducer or integrated gear unit** in various gear ratios, plus (digital) **AC servo motor** with control unit
- ▶ **Maintenance-free sealing system** thanks to gap seal and belt guidance by aluminum frame (in closed axes)

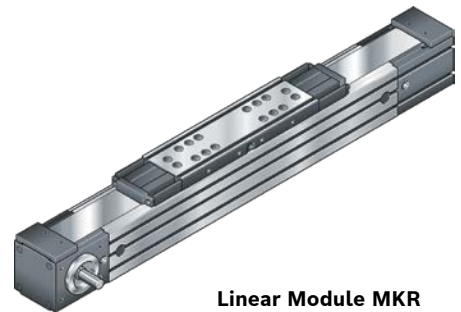
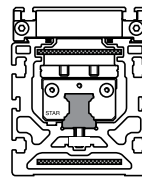

Linear Module MKR

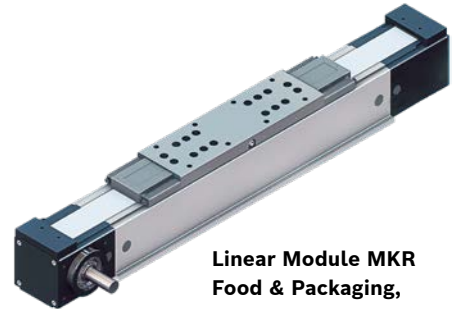

**Linear Module MKR
Food & Packaging,
slotless frame**

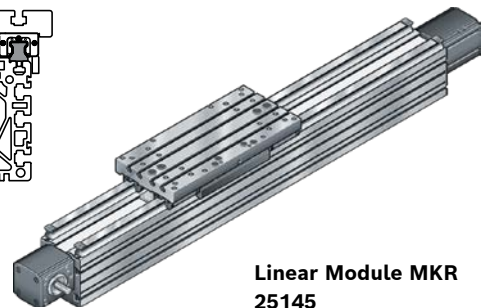
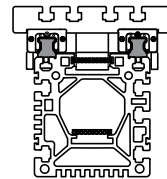

**Linear Module MKR
25145**

Linear Module MKR with belt drive

Linear module for moving heavy loads at high speed thanks to high load ratings and optimal travel performance. For implementation of processes with high moment loads.

Comes in six sizes, configurable in millimeter increments, with one or two Ball Rail Systems, available in lengths up to 12,000 mm. Belt guided by the aluminum profile. With plastic/corrosion-resistant steel sealing strips and gap seal. Gear reducer with various gear ratios for optimizing external load to motor inertia.

Omega Modules

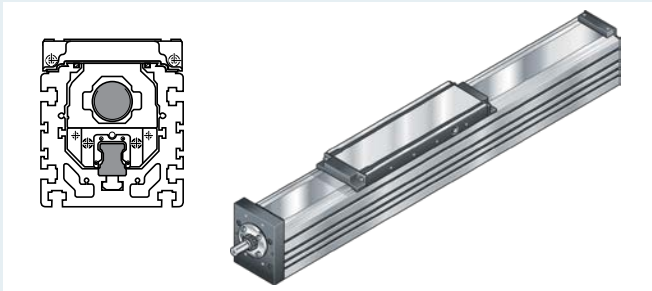

Linear Module MKK with Ball Screw Drive

Linear module with high thrust forces, ideally suited for applications requiring high load ratings and high positioning accuracy and repeatability.

Available in five sizes in lengths up to 4,900 mm.

Rolled, precision Ball Screw Drive and zero-backlash Cylindrical Single Nut. Depending on the size, the drive unit may be covered with a special plastic strip with integrated steel cords, a corrosion-resistant steel strip, or high-quality bellows. Also available with screw support (MKK110).



Linear Module MLR with Cam Roller Guide and belt drive

Linear module with integrated zero-backlash Cam Roller Guide whose special design makes this module ideal for very high speeds up to 10 m/s.

Available in two sizes up to a length of 10,000 mm.

Gear reducer with various gear ratios for optimizing external load to motor inertia. Longer lengths available on request.

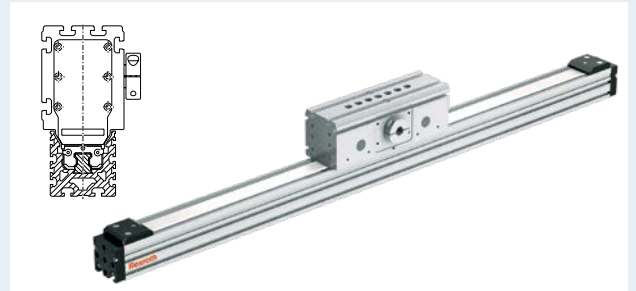

Omega Module OBB with Ball Rail System and belt drive

Linear motion system with high-level dynamic capabilities. The table-mounted drive makes the modules ideally suited to applications involving deep immersion into the work area. It is also possible to make the frame stationary and operate multiple carriages independently with their own drives.

Available in three sizes up to a length of 5,500 mm (for stationary frame; lengths over 1,500 mm not recommended for mobile frame).

Precision Ball Rail System. Belt drive that winds around the gear wheel in the form of the Greek letter omega. Drive mounted on the carriage to reduce the moved mass of the frame. Multiple, independently mobile carriages possible. Clamping elements for maintaining position available.

Feed Modules

Feed Module VKK

Rexroth Feed Modules VKK are precise, ready-to-install linear systems with high performance features in compact dimensions. They are particularly suitable for handling tasks that require high precision and simultaneously place high demands on force and torque transmission. Due to the low moving mass, Feed Modules VKK are ideal for use as Z-axes in vertical movements.

Characteristic features

- ▶ Optimal travel, high load capacity, high rigidity thanks to the integrated, zero-backlash Ball Rail System
- ▶ Inexpensive maintenance thanks to the one-point lubrication feature (grease lubrication) of the Ball Rail System and Ball Screw Drive
- ▶ Fully compatible with the EasyHandling system
- ▶ Easy mounting of diverse attachments



Feed Module VKK with Ball Screw Drive

Compact aluminum section with steel reinforcement technology, in which a combination of aluminum and steel provides excellent performance. Integrated precision Ball Screw Drive (BASA) according to tolerance class 7 with zero-backlash nut system.

Linear Motion Slides

Closed design for unsupported units

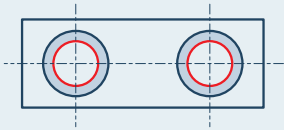

With Super Linear Bushing **SLB**, closed, self-aligning

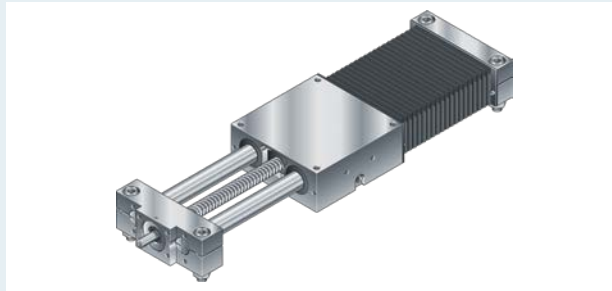
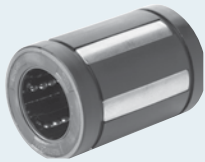

Linear Motion Slide with Ball Screw Drive SGK

Economical Linear Motion Axis version for high thrust force. Boot sealed by unsupported linear guides for excellent protection against contamination. Ball Screw Drive with tolerance grade T7 and zero-backlash cylindrical nut. Available complete with motor, timing belt side drive, motor mount and coupling.

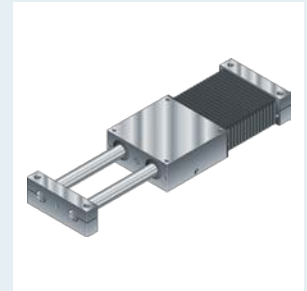

Linear Motion Slide without drive SGO

Two precision steel shafts with two aluminum end blocks, four Super Linear Bushings and aluminum carriage. Also available with boot.

Open design with supported shafts

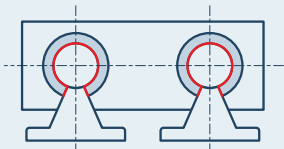

With Super Linear Bushing **SLB**, open, self-aligning

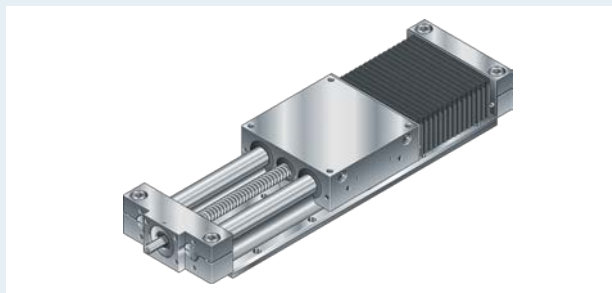
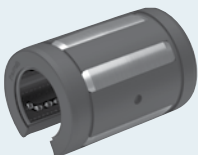

Linear Motion Slide with Ball Screw Drive SOK

Economical Linear Motion Axis version. No deflection thanks to supported shafts permitting longer lengths than with the SGK model. Available complete with motor, timing belt side drive, motor mount and coupling.

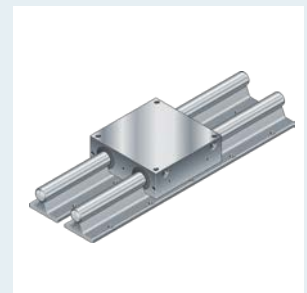

Linear Motion Slide without drive SOO

Two precision steel shafts with aluminum shaft support rails, four Super Linear Bushings and aluminum carriage. Also available with boot.

Electromechanical Cylinder EMC: compact, precise and ultra-flexible



The latest Electromechanical Cylinder EMC is a perfect example of Rexroth's wealth of system expertise with its consistent integration of proven in-house technologies. The result is an actuator that may look and work like a pneumatic cylinder, but is substantially more energy-efficient and flexible. This makes it more than just an alternative to pneumatic linear drives in many industries.

Complete system: hygienic, variable, precise

Its high variability makes the new EMC so interesting for many industries and applications. An affordable, simple base cylinder can be adapted with countless options to suit practically any customer need. Hygienic, highly resistant to chemical corrosion, fully sealed and with a high IP rating. These options ensure long service life even in harsh industrial conditions. The powerful EMC always performs with high efficiency, regardless of use.



The actuator is available available in seven sizes, from 32 to 100 in accordance with ISO 15552, with axial forces up to 56 kN and travel speeds up to 1.6 m/s, as well as any length up to a stroke of 1,500 mm. Customizable with various motor attachment options, fastening elements and an array of servo motors for configuring a complete system.



Characteristic features

- ▶ Hygienic design: highly resistant to chemicals and cleaning agents
- ▶ Excellent sealing: IP65 rating, sealed against outside dirt and water and lubrication leakage from the cylinder
- ▶ Optimized lubrication concept: optional connection to a one-point lubrication system reduces downtime, saving time and money
- ▶ High-precision Ball Screw Drives: for high performance with maximum cost-effectiveness
- ▶ Complete building system with outstanding variability: perfectly adaptable to customer applications
- ▶ Complete turn-key system: minimal design and installation effort
- ▶ Intelligent drive system for open programmability and complex travel profile implementation

Electromechanical Cylinder EMC-HD: for moving extra heavy loads without extra power

4EE
ENERGY
EFFICIENCY



Key technical data

- ▶ Dynamic load rating (C_{dyn}): 50–470 kN
- ▶ Axial force: up to 290 kN (tensile/compressive)
- ▶ Max. travel speed: 1 m/s
- ▶ Stroke: up to 1,700 mm
- ▶ International protection rating: IP65
- ▶ Connectivity with sercos and multi-Ethernet



This robust Electromechanical Cylinder was developed for use in heavy-duty applications. As a complete building system with integrated Planetary Screw Assembly or Ball Screw Drive, it is designed for efficient operation even under harsh conditions.

Robust, complete building system

The new heavy-duty Electromechanical Cylinder was created for long service life under harsh conditions: A complete seal gives it a high IP rating and excellent corrosion protection. The precision-rolled Screw Drives feature precise and powerful positioning, excellent economy, low operating costs, and high energy efficiency. The configurable servo drive is openly programmable; process parameters can be modified with ease for precise implementation of even complex travel profiles that can be altered at any time.

Advantages of special product features

- ▶ High energy efficiency and small environmental footprint
- ▶ No leakage
- ▶ Simple, rugged design for long service life, even in harsh environments
- ▶ Complete building system with great variability for high flexibility
- ▶ Precise positioning, high dynamics, powerful drive and a long service life thanks to precision screw drives
- ▶ Optional connection to a one-point lubrication system reduces downtime, saving time and money
- ▶ Low design and installation effort with complete turn-key system
- ▶ Intelligent drive system for open programmability and complex travel profile implementation

Beyond linear motion: more components, systems and solutions from Rexroth

Rexroth is The Drive & Control Company. And Rexroth is unique – because no other brand in the world can offer its customers the complete panorama of all drive and control technologies. Our powerful and broad range of linear motion products is yet another example of our multi-industry and multi-system expertise. With components designed to work perfectly together and intelligently engineered systems, we create economical solutions for manufacturing lines and machine construction.

To find out more about the broad diversity of our offerings, simply visit: www.boschrexroth.com

Our ambition is to be technology leaders, and we demonstrate this continuously through innovations and through our unequalled partnering with our customers. Of course, our closely linked sales infrastructure provides all the support you need in finding the solution you are looking for – either through personal consulting or comprehensive informational materials.

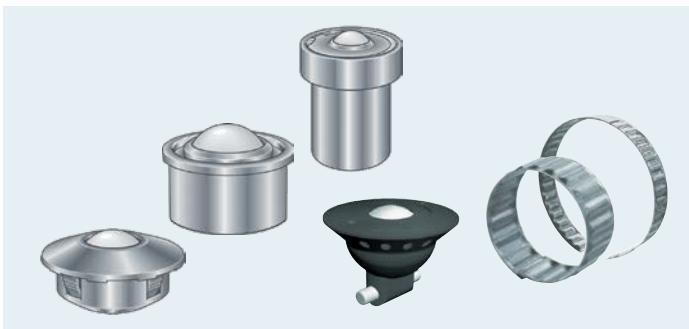

Engineering components and machine elements

- ▶ Ball Transfer Units
- ▶ Tolerance Rings



Components and systems for Assembly Technologies

- ▶ Manual Production Systems
- ▶ Basic Mechanical Elements
- ▶ EcoShape tubular framing system

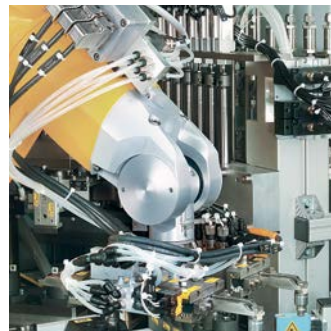

System solutions for Factory Automation

- ▶ Transfer Systems
- ▶ Chain Conveyor Systems
- ▶ ID Systems
- ▶ Customer-specific system solutions

Rexroth offers still more...

- ▶ Electric drives and controls for machine construction and handling technology
- ▶ Hydraulic components and systems for stationary and mobile applications

A true partnership that brings you real benefits



With us, you profit not only from a unique range of components and systems but also from outstanding human and technical skills. Moreover, we continuously expand our expertise and work hard on enhancing our technologies and our performance still further. All to your benefit.

We understand partnership as being there for you – anytime, anywhere

Our partnership has many different facets. A technological one, because Rexroth offers all drive, control and motion technologies with cross-system integration from a single source. A geographical one, because Rexroth is represented in more than 80 countries around the globe. And a supportive one, because we make sure you have everything you need for your application – through personal assistance, sophisticated eTools, and comprehensive media resources.



**Face-to-face consulting**

Direct and professional – there is no substitute for person-to-person consulting. Because a direct dialog is the best and fastest way to learn about your needs, wishes and special requirements, so that they can be considered in all downstream steps.

Personalized assistance

Each requirement calls for its own particular solution. This is why personalized assistance is a core feature of our services to you. From the initial consultation and provision of efficient technical support through to planning and engineering of complete projects, we will be ready with competent advice to help you accomplish your goals. With our team of highly qualified professionals, we engineer custom solutions that deliver the best results for you.

Brochures and information

You can access the latest information about our portfolio at any time. Our brochures and catalogs contain valuable product information. You can download them from our website or order printed versions online.

Modern media support – saving time with intelligent tools

Media support and eTools

Rexroth's extensive eServices provide time-saving support, beginning with eTools and stretching all the way to complete handling of all business processes and transactions electronically – directly and 24/7.

Our aim is to be at our customers' side from the very first moment.

Take advantage of the targeted support we provide, both online and offline, for configuration, engineering and procurement. Make use of our calculation and configuration programs, eTools and aids to get fast and efficient results.



Selection, configuration and procurement – online: www.boschrexroth.com

Use the whole range of Internet resources. On our website, you'll find many useful eTools, which can help you save a lot of time during product searches, design calculations and procurement.

Online selection guide

From problem to solution in just a few clicks – with its completely new approach, our online program simplifies the planning of automation tasks.

Online product configurator

Configure custom products to suit your needs – with the online catalog and various product configuration tools, you can configure complex products yourself. The results can be generated as 3D CAD files in common formats to support your design engineers.

Screw Drive configurator

Order Screw Drives with unparalleled speed and simplicity with our online configurator. Conveniently integrated in the Rexroth eShop, you can order standard components directly or run through an image-guided configuration process to find the exact solution you need.

Bosch Rexroth eShop

Open 24/7 – in our multi-technology eShop you can order products in most countries and check the availability and earliest possible shipment date. This is a great advantage when ordering standard products or placing repeat orders.



Design calculations and configuration

Get optimal results in a few short steps. Our user-oriented professional software packages help you to do just that. From design calculations to complete project planning, they make sure you'll obtain a perfect solution every time.

Linear Motion Designer

Sizing profiled guide rails correctly – this intelligent software covers the entire spectrum of Rexroth guide rails and is an ideal tool for use by design engineers.

For easy calculation and configuration of Ball Screw Drives. This program allows you to select and size exactly the components you need to make up the assembly that best fits your application.

LinSize

Selecting and sizing servo motors for Linear Motion Axes – this tool uses application support from Rexroth to help you select the right products quickly and easily.

CAD configurator

The CAD configurator can be used to design and download CAD models of single and multi-axis systems in the most commonly used formats. Model data can be entered directly or conveniently taken from an EasySelect project.

LinSelect selection and sizing tool for Linear Motion Axes and Actuators

Rexroth has fundamentally simplified the selection and sizing of Linear Motion Axes with the LinSelect tool. The clear and intuitive user interface guides you to the best option step by step. This saves you time and money.

Delivered in a flash

In today's global competition, every day counts. Fast response times have become an important success factor for machine and system manufacturers. Reliable, on-time delivery of machine components plays a critical role in this regard – especially when talking about individual and custom machine builders. With Rexroth's GoTo Focused Delivery Program, you benefit from easy ordering processes and on-time delivery of our most popular products across our broad range of technologies.

You will receive the most popular Rexroth products from industrial and mobile hydraulics, electrical power, control and screwdriving technology, as well as linear motion and assembly technology, always on time. Product-based maximum order quantities available across Europe with unbeatable simplicity. Construct your own machines and systems quickly and efficiently – we're happy to assist.

Your advantages

- ▶ Reduced inventories and capital tie-up thanks to short, reliable delivery times
- ▶ Flexible response to customer and market demands through high availability of many products
- ▶ Simple and fast ordering via e-mail, fax, post or e-commerce at Bosch Rexroth or its sales partners



Your product is just three steps away



1. Select the product



2. View the product data



- ▶ Product-specific information
- ▶ Availability
- ▶ Maximum order quantities
- ▶ Delivery times
- ▶ Prices

1. Select the product

Use the GoTo product overviews to find the desired products.

2. View the product data

Now visit the Focused Delivery Program website – www.boschrexroth.com/goto. It offers simple access to additional product information, including data sheets, part numbers, specifications, downloads and more.

3. Order the product

To order, contact Rexroth, your sales partner, or simply order online via our eShop: www.boschrexroth.com/eshop

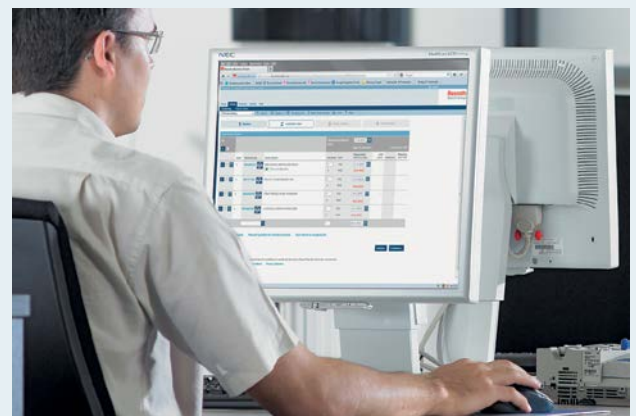

Bosch Rexroth Corporation

Corporate Headquarters
14001 South Lakes Drive
Charlotte, NC 28273
Telephone (800) REXROTH
(800) 739-7684
info@boschrexroth-us.com
www.boschrexroth-us.com

Find you local contact person here:

www.boschrexroth-us.com/contactus