

# Control block EDD Modular Directional Valve





Bosch Rexroth Oil Control S.p.A. introduces the EDD size 08 directional control valve with up to 80 l/min to the Bankable product line. These allow electrohydraulic control of actuators (motor or cylinders) in open circuit applications. It is an ideal solution for mobile and industrial applications when the required flow rate is over standard D03.

#### Features

- § Modular directional elements
- § **Up to 80 l/min** (21 GPM) flow for single functions.
- § Same flange interface as the ED series
- § Optional Integrated antishock valve on A & B ports
- § Direct acting solenoid operated directional spool

#### Advantages

- § Cast body design for performance to size and weight optimization
- § Streamlined design for minimized pressure drop
- § Efficient solenoid system to maximize flow capacity and spool shift performance
- § Zinc plated body and pole tubes for superior corrosion resistance

#### EDD - Technical Data

- § Max. pressure: 310 bar (4500 psi), A & B: 380 (5500 psi)
- § Max. flow: 80 l/min (21 GPM)
- § Ports connection: A & B, SAE 10

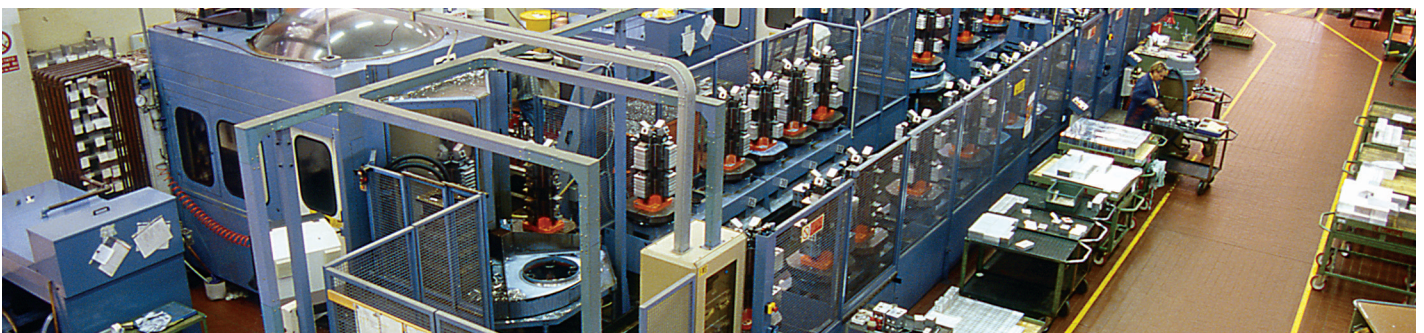

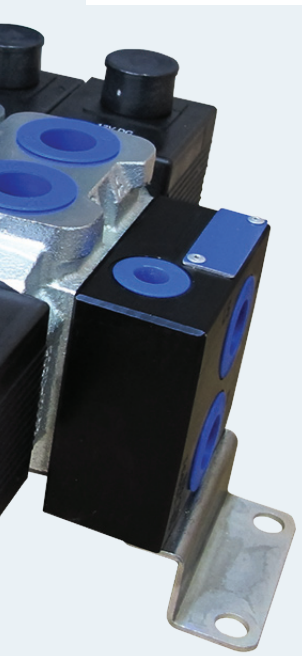
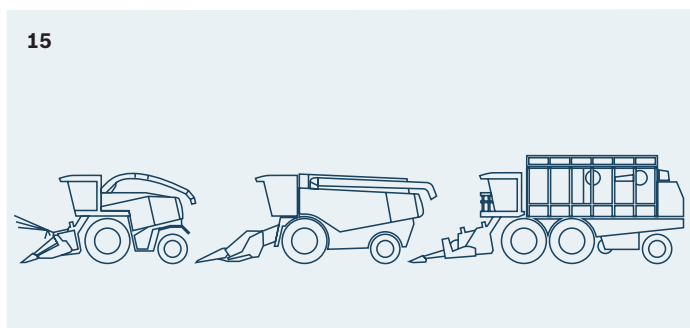
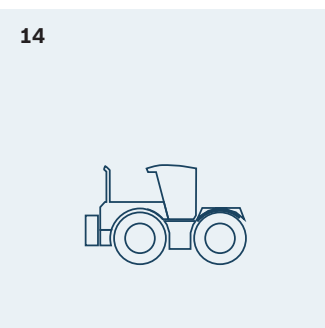
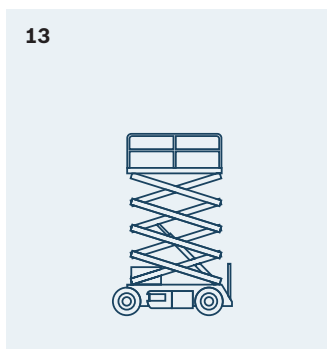
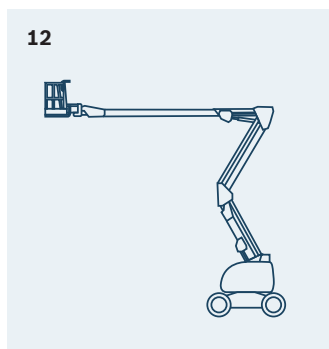
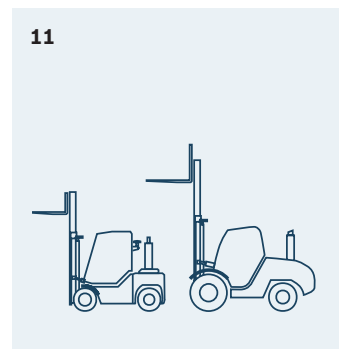
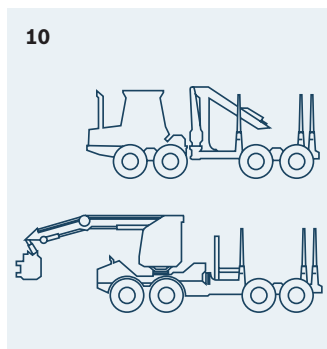
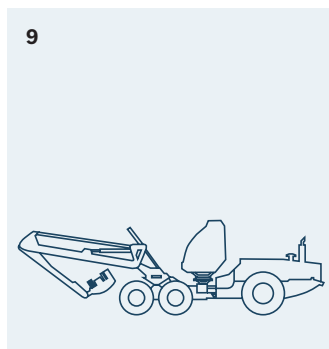
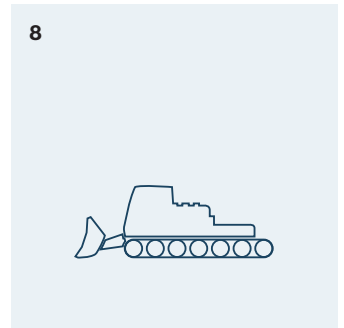
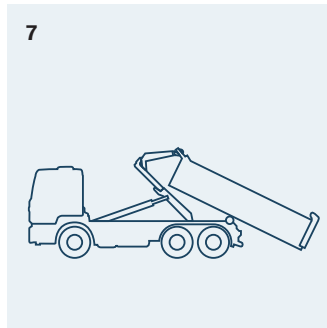
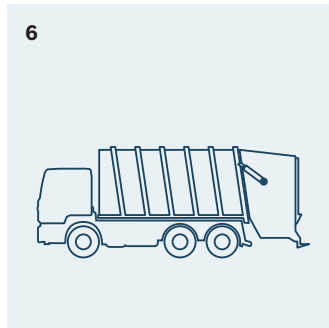
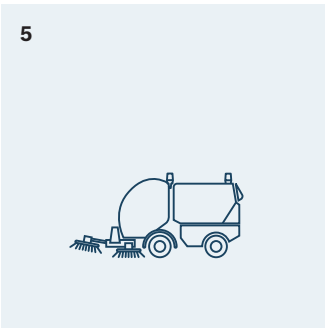
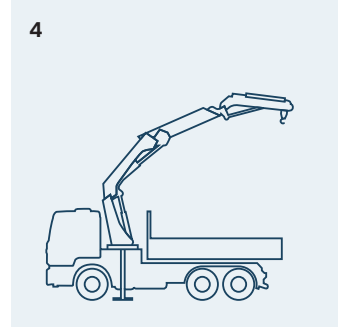
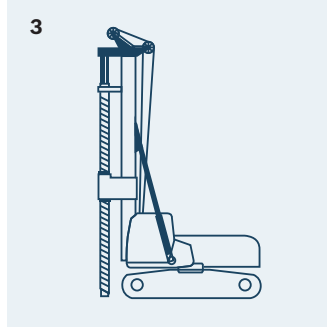
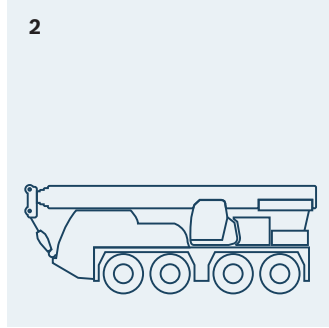
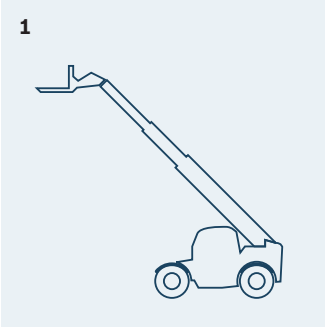

**Mobile Applications**

- § 1. Telehandler
- § 2. Cranes
- § 3. Drilling machine
- § 4. Truck mounted crane
- § 5. Road sweeper
- § 6. Garbage truck
- § 7. Hook loader
- § 8. Dozer
- § 9. Special excavators
- § 10. Forest machinery
- § 11. Fork lift truck
- § 12. Aerial work platform
- § 13. Scissor lift
- § 14. Tractors
- § 15. Harvesters

# EDD – Control block

Solenoid operated, spring return, 4/2 or 4/3 directional control valves.  
 Load sense, A & B port anti-shock, and anti-cavitation options available.



Anticavitation and antishock

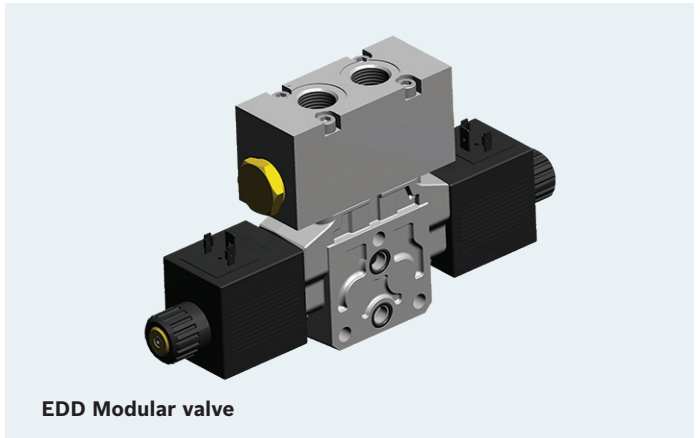

EDD Modular valve

# Assembly drawing example

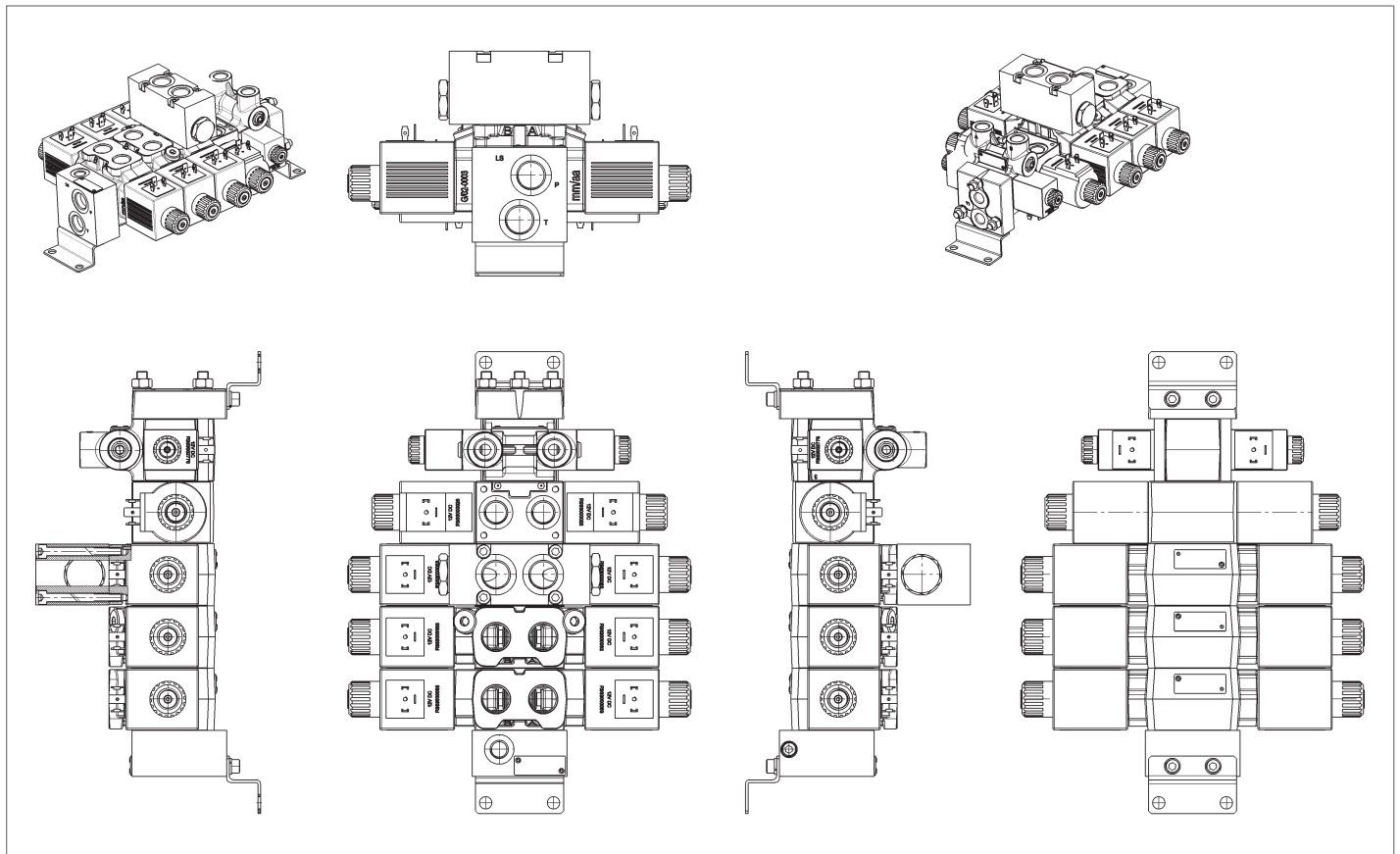

- § Compact design
- § Common valve interface; can be mounted with all types of ED- and Ti-series bankable sections
- § Simplified hydraulic circuit
- § Integrated antishock valve on A/B
- § Electrically operated on-off direct acting elements with optional LS

# EDD – Modular directional valve

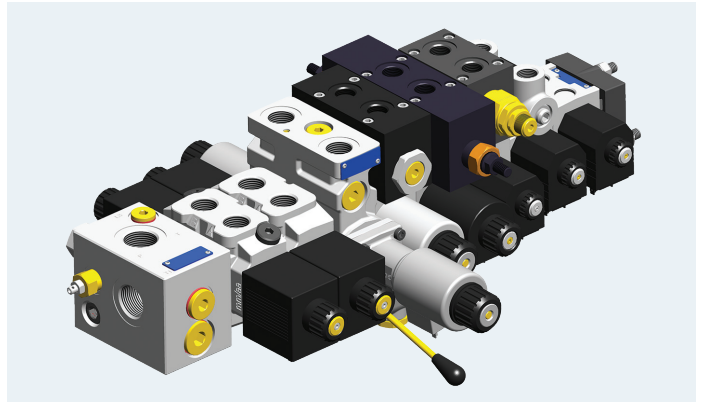
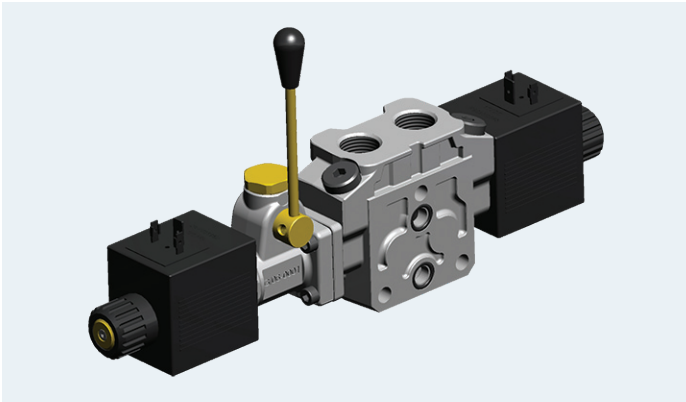

<b>Port</b>			SAE 10
<b>Maximum flow</b>		l/min (gpm)	80 (21)
<b>Maximum operating pressure</b>	P	bar (psi)	310 (4500)
	A, B	bar (psi)	380 (5500)
	T	bar (psi)	250 (3625)
<b>Maximum number of directional valves</b>			10
<b>Actuation</b>	Electrical		Solenoid operated direct acting on/off
	Override	type	Push button, screw type
<b>Voltage supply</b>			DC: 12, 13, 24, 27, 48 RAC: 24, 110, 230
<b>Electrical connections</b>			DIN EN 175301-803, AMP-J, Deutsch DT04-2P

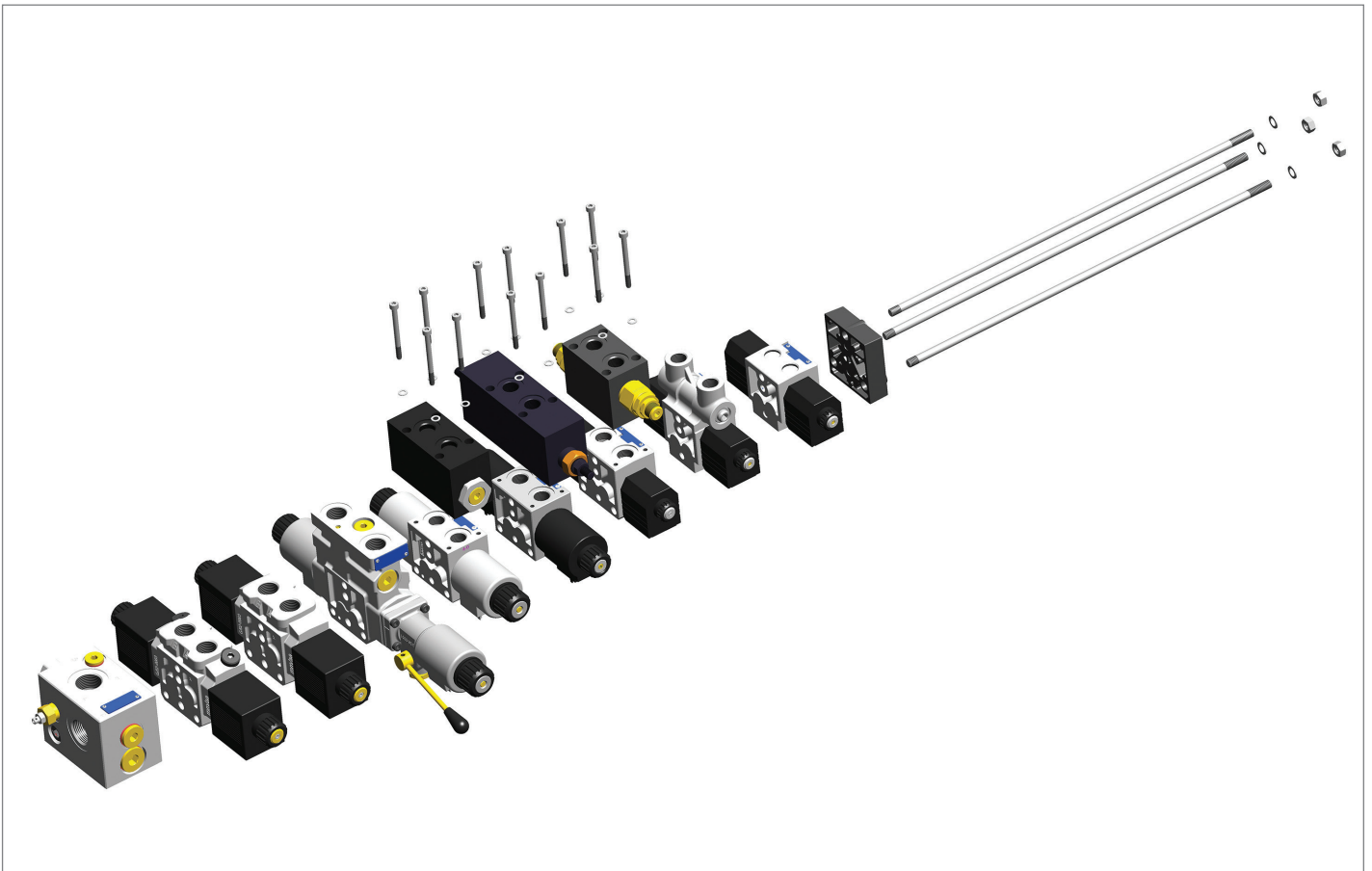

# EDD – Configurations

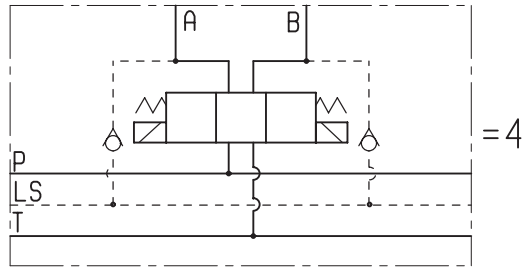
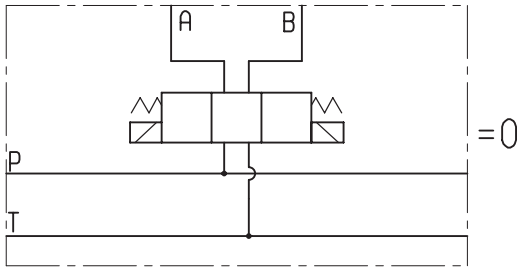

## Secondary valves, possible configurations

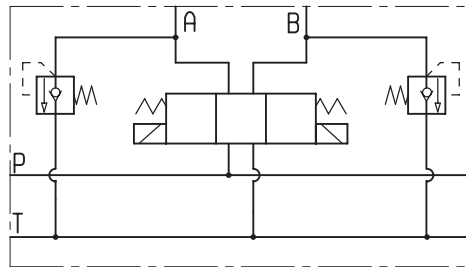
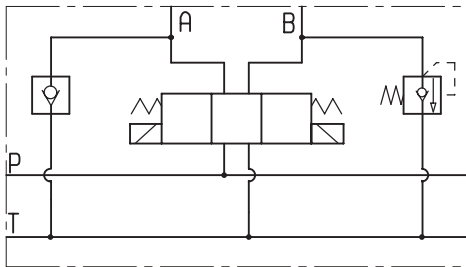
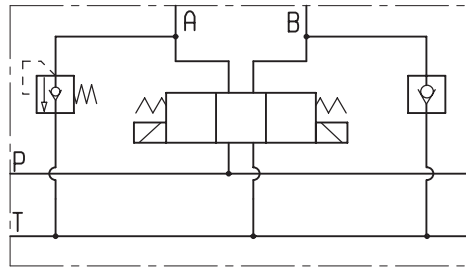
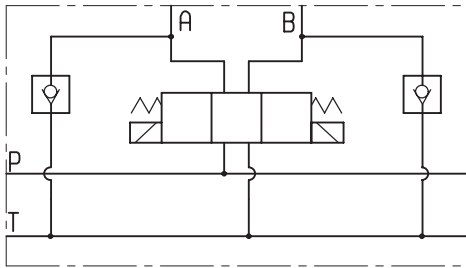

## Flangiabe version = M

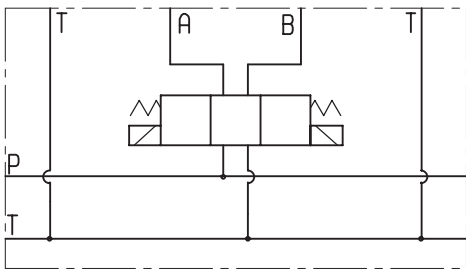

## Spool Variants

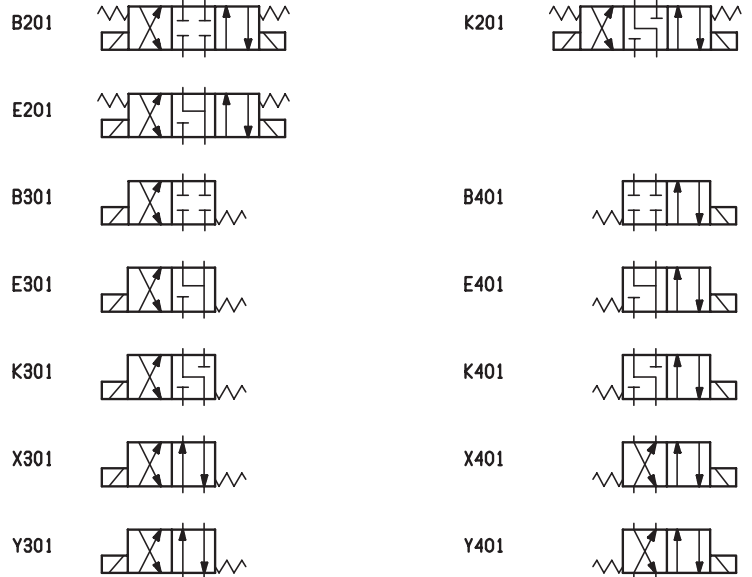

## EDD – Cross section

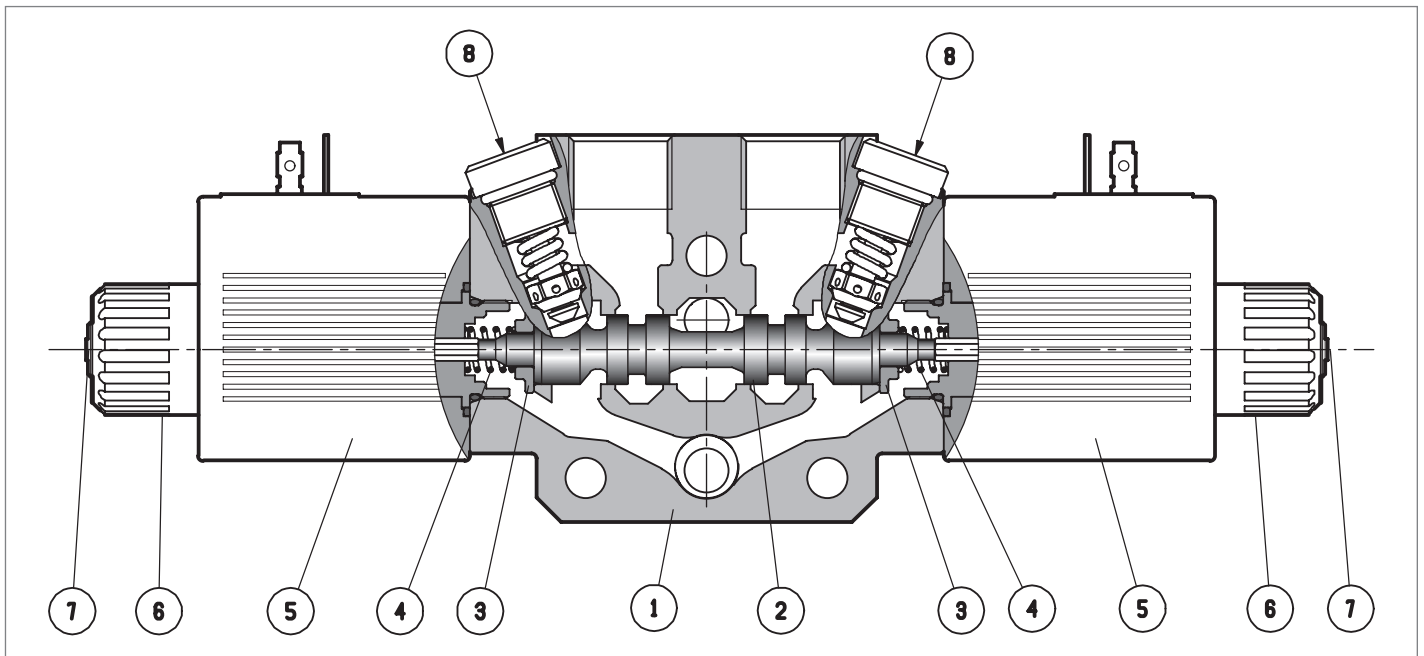

### Principles of operation, cross section

The sandwich plate design directional valve elements D8\_5 are compact direct operated solenoid valves which control the start, the stop and the direction of the oil flow. These elements basically consist of a stackable housing (1) with a control spool (2), one or two solenoids (5), and one or two return springs (4). The spring chambers are connected to the tank port. When the coil is energized, the spool (2) travels and oil is pushed to tank from one of the spring chambers. When energized, the force of the solenoid (5) pushes the control spool (2) from its neutral-central position to the required position, and the required flow from **P to A** (with **B to T**), or **P to B** (with **A to T**) is achieved. Once the solenoid is de-energized, the return spring (4) pushes the spool thrust washer (3) back against the housing and the spool returns in its neutral-central position. Each coil is fastened to the solenoid tube by a ring nut (6). A pin (7) allows to push the spool (2) in emergency conditions, when the solenoid cannot be energized, like in case of voltage shortage. The secondary cartridge valves are designed for quick response and stable pressure control (8); they also incorporate a reverse flow check for anti-cavitation.

**Bosch Rexroth Oil Control S.p.A.**

Via L. da Vinci, 5

I - 41015 Nonantola (MO), Italy

Tel +39 059 887 611

Fax +39 059 547 848

[www.boschrexroth.com/compacthydraulics](http://www.boschrexroth.com/compacthydraulics)

[compact-hydraulics-cdv@boschrexroth.com](mailto:compact-hydraulics-cdv@boschrexroth.com)

The data specified above only serve to describe the product. No statements concerning a certain condition or suitability for a certain application can be derived from our information. The information given does not release the user from the obligation of own judgment and verification. It must be remembered that our products are subject to a natural process of wear and aging.

RE 98352/09.2013

© Bosch Rexroth Oil Control S.p.A. - All rights reserved.

Printed in Italy