

# Compact, performing, flexible, energy saving: E-valve

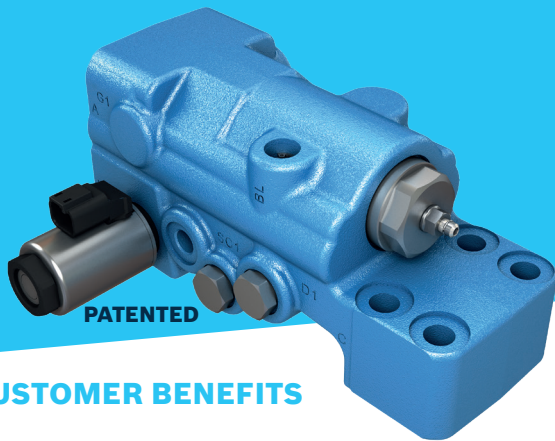

## CUSTOMER BENEFITS

- Compact and flexible solution
- Lower pressure drop
- Simplified installation - no hydraulic pilot piping
- Metering and lowering speed control optimization via software
- Electronic pressure compensation with current profile adaptation
- “Ghost mode”: further  $\Delta p$  reduction during lowering
- Energy saving
- Calibration by software tuning
- Fine control
- Reduced hysteresis
- Reduced overshoot in relief function

## TECHNICAL DATA

Size	Flow	Pressure	Flange
2.5	up to 250 l/min	420 bar	1/2" and 3/4" SAE 6000
5.0	up to 500 l/min	420 bar	3/4" and 1" SAE 6000

## APPLICATIONS

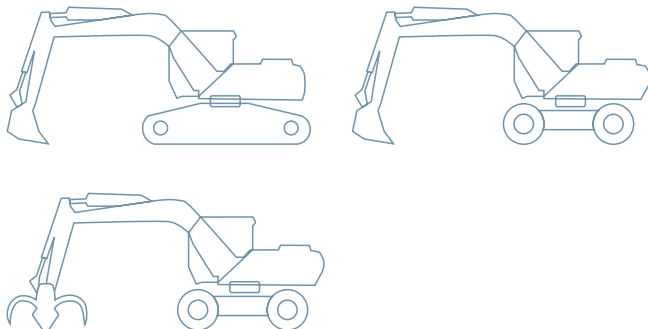

## THE NEW CHECK AND METERING E-VALVE

Bosch Rexroth is expanding its range of check and metering valves with the introduction of the new **E-valve**. Perfectly suited to 08-ton 40-ton excavators, the new valve boasts optimal installation design and, thanks to its electronic control and set-up, offers a very fine movement controllability and adaptation to all machines. It is also possible to significantly reduce fuel consumption and the working cycle time by switching the valve to “ghost mode”.

With electronically controlled excavators becoming increasingly sophisticated, the new E-valve fulfils market demands superbly. By using an electro-proportional pilot stage, Bosch Rexroth can provide a flexible solution that is electronically controlled and cost effective from the installation point of view by removing the pilot piping and making all hydraulic ports rear mounted. Moreover the special manifold design allows the right installation without any flange adapters.

Electronic control of the valve makes it possible to achieve optimized movements control, electronic pressure compensation and simple adaptation to all machines with an improved performance that has not until now been possible with standard products. Furthermore, the “ghost mode” makes it possible to save energy during lowering and faster movements.

For this new valve, a new improved die cast housing has been developed which permits very low pressure loss in combination with a very compact manifold. The resulting valve is 21% lighter with a pressure drop reduction of 46% compared to the existing check and metering valves. Furthermore, the new valve guarantees very low hysteresis and peaks of pressure in relief function ensuring reduced stress for the cylinders. One solution to cover a wide range of machines: size 2.5 for flow rates up to 250 l/min and size 5.0 for flow demands up to 500 l/min.

[compact-hydraulics-pib@boschrexroth.com](mailto:compact-hydraulics-pib@boschrexroth.com)